

NAVIGATOR

Effective Cleaning for Small Process Pipe with Bends

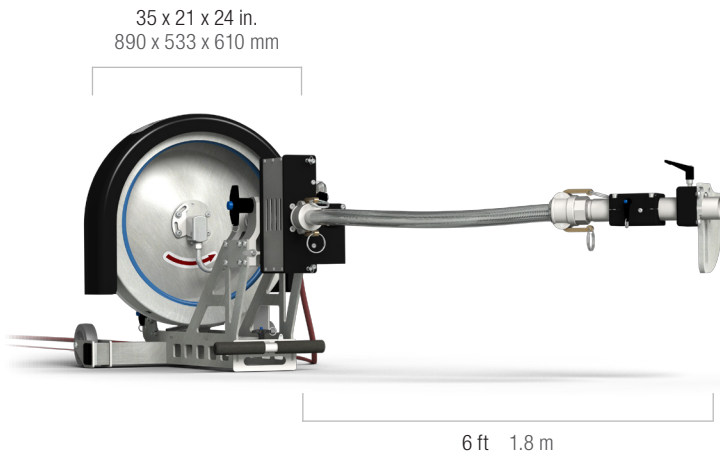

OVERVIEW

The StoneAge Navigator is specialized for cleaning welded process piping, drain lines, and tubes 2–4 inches (51–102 mm) ID. Hose rotation enables access through multiple bends in small diameter conduit.

COMPETITIVE ADVANTAGES

- The only automated rotary hose device in the industry specifically engineered to clean small diameter process pipe with bends
- Utilizes the proven AutoBox ABX-PRO hose tractor – can be removed and used independently
- Cleans past multiple bends and elbows using hose rotation and StoneAge’s proven self-rotary tools

FEATURES	BENEFITS
<ul style="list-style-type: none"> • Utilizes the proven AutoBox ABX-PRO hose drive 	<ul style="list-style-type: none"> • System can function as a RHD or a stand-alone ultra-portable single-lance pipe cleaner • Common snout and, mounting assemblies, backout prevention, and spare parts packages • Achieve high rates of hands free automation work in all plants
<ul style="list-style-type: none"> • Controlled hose rotation 	<ul style="list-style-type: none"> • Allows nozzles to pass multiple bends in welded joint pipe as small as 2 inches (51 mm) ID • Bid new jobs to clean process piping, drain lines, and other small ID conduit that may have been inaccessible in the past
<ul style="list-style-type: none"> • Hose containment 	<ul style="list-style-type: none"> • Increases job site safety and greatly reduces hose wear and costly replacement • Holds 100 ft (30 m) of hose for 85 ft (26 m) reach
<ul style="list-style-type: none"> • Lightweight, modular system 	<ul style="list-style-type: none"> • Portability and easy assembly – each module fits through a 24” manway • Requires only a single operator to move, set up and run, freeing up crew to man other jobs
<ul style="list-style-type: none"> • Adjustable forward and reverse feed rate 	<ul style="list-style-type: none"> • Customize dwell time for consistent cleaning in both directions, better results in less time
<ul style="list-style-type: none"> • Integrated snout with versatile flange mount and cam-lock attachment 	<ul style="list-style-type: none"> • Simplifies attaching to pipes and increases safety • Quick setup in varied application environments
<ul style="list-style-type: none"> • Intuitive and ergonomic control box 	<ul style="list-style-type: none"> • Operate all features from outside the blast zone for safety and better line of sight

NAVIGATOR CONFIGURATION

CONSIDERATIONS

- **Do you already own an AutoBox ABX-PRO hose tractor?**
The ABX-PRO can be upgraded to the full Navigator system with the NAV-170-PKG upgrade kit. See the configuration section on the following pages for package details.
- **What size hose are you using?**
Collet size will be determined by hose size.
- **Does the pipe have a flange?**
If no flange, a strap mount will be required to mount the system. If using a strap mount, a splash plate may also be required.

ADDITIONAL INFORMATION

- 4-wrap hose is required for use with the Navigator in applications with hose rotation for passing multiple bends. The length of hose crimp may limit the bend radius through which a tool can pass. 5/4 or 6/4 hose with shorter crimp is recommended for cleaning past elbows.
- The Navigator is designed to work with smooth, welded joint elbows. Threaded connections have inherent irregularities that disrupt the traversal of a rotary tool through the line.
- Feed rate is a function of 1) pipe size, 2) number of elbows, 3) desired level of cleanliness. **Speeds no greater than 14 in/sec (356 mm/sec) are recommended for cleaning pipes with elbows.**
- Use tools with right-hand thread for additional safety – the rotation of the device will correlate with tightening the tool in case of resistance in the pipe.
- The Navigator is well suited for Beetle and 2" Badger tools.

TOOL SPECIFICATIONS

MODEL	NAV-100
Pipe Size	2–4 in. 51–102 mm
Hose Size*	4/4, 5/4, 6/4
Feed Rate	1.0–32 in/sec 25–813 mm/s
Hose Capacity	Storage: 100 ft 30 m Reach: 85 ft 26 m
Maximum Pressure	20k psi 1400 bar
Inlet Connection	3/4 MP (MP12)
Dimensions	35 in. x 21 in. x 24 in. 89 cm x 53 cm x 61 cm
Snout Length	72 in. 182 cm
Snout Diameter	2 in. 51 mm
Weight	85 lb 38.5 kg

*4-wrap hose required

Visit our website for tool resources including operation and maintenance videos:

WWW.STONEAGETOOLS.COM

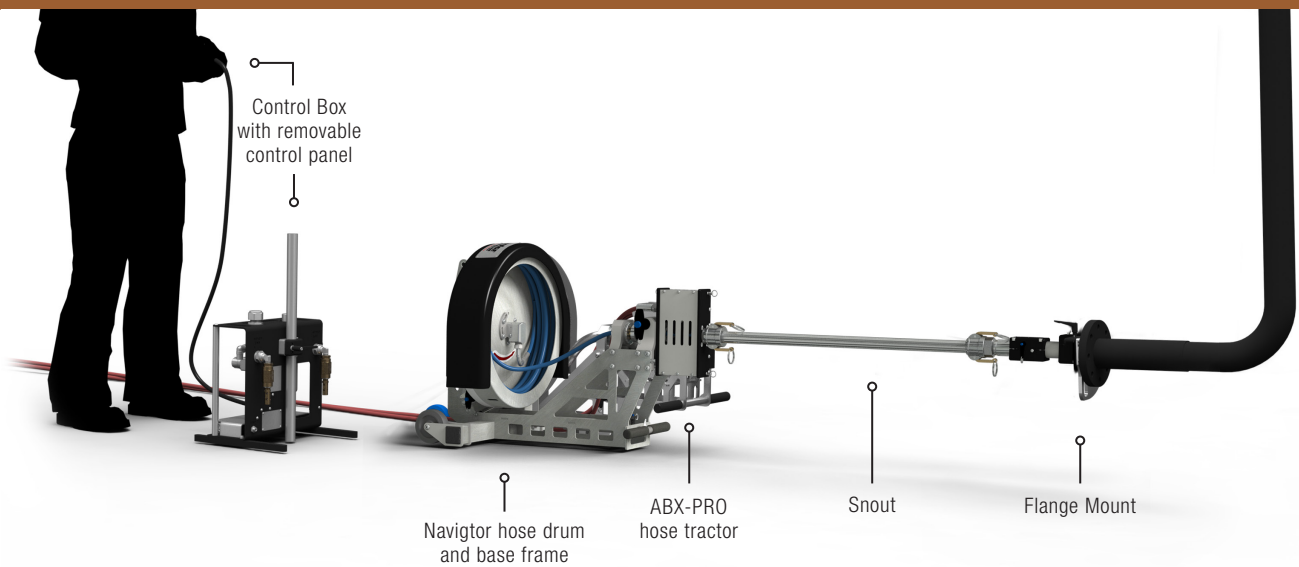

ORDERING THE PACKAGE

StoneAge offers a preconfigured Navigator base package that can be ordered in a single Part ID:

PACKAGE PART ID	PACKAGE CONTENTS
NAV-100-PKG	1 x NAV-100 Navigator assembly
	1 x BOP 010-2-4-QTR Quarter plate assembly, 2-4in
	1 x BOP 030 Collet Block Assy
	1 x BOP 081-6 Tube, Snout, SS, 6in
	1 x BOP 084 Tube, Snout, Alum, 1.75 x 1.25
	1 x BOP 085 Hose Coupling, Alum, 1.25 NPT
	1 x BOP 090 Snout, Corrugated, 1.25 Camlocks
	1 x ABX-PRO AutoBox ABX-PRO tractor assembly
	1 x PRO 174-46-K 0.46" Roller Kit
	1 x FF 121-XXX* Hose stop collet
	1 x CB-NAV Control box

*Specify collet size based on hose

Current owners of AutoBox ABX-PRO hose tractors can upgrade to the full Navigator with the upgrade package:

PACKAGE PART ID	PACKAGE CONTENTS
NAV-170-PKG	1 x NAV-170 Navigator Base and Drum Assembly Only*
	1 x FF 121-XXX** Hose stop collet
	1 x CB-NAV Control box

*Requires ownership of an ABX-PRO, Snout and Flange Mount **Specify collet size based on hose

Optional items can be ordered separately.

NAVIGATOR CONFIGURATION

Hose Options

PART ID	DESCRIPTION
NAV 192-75	Hose, 4/4, 9/16 Type M x 3/8 RH HP Male, 75 ft
NAV 192-100	Hose, 4/4, 9/16 Type M x 3/8 RH HP Male, 100ft
NAV 190-75*	Hose, 5/4, 9/16 Type M x 3/8 RH Male Blastpro, 75ft
NAV 190-100*	Hose, 5/4, 9/16 Type M x 3/8 RH Male Blastpro, 100ft
NAV 191-75*	Hose, 6/4, 9/16 Type M x 3/8 RH Male Blastpro, 75ft
NAV 191-100*	Hose, 6/4, 9/16 Type M x 3/8 RH Male Blastpro, 100ft

*Recommended for multiple bends due to shorter crimp size

Hose Stop Options

The Navigator hose feed assembly comes installed with Ø.46 rollers. **A collet stop is also required.** Select the appropriate collet based on the hose being used.

ROLLER	HOSE OD	SPIR STAR	PARKER	COLLET	KIT
PRO 174-46 Ø 0.46 in.	0.39–0.50 in.	4/4	2440D-025, 2448D-025	FF 121-438	NAV 621 1 each, all sizes
		5/4		FF 121-460	
			2440D-03	FF 121-484	
		6/4	2440D-04	FF 121-516	

Please Note: A collet is required when using Banshee and Beetle series tools. It is the responsibility of the user to select proper sizing to ensure the end sleeve of the hose will not pass through the collet.

Other Options

PART ID	DESCRIPTION
PRO 174-46-K	Kit, Roller, Poly Urethane, .46 (2 rollers)
BOP 010-4-8	Flange Mount Plate Assy, 4in-8in
BOP 050	Strap Mount Assy
BOP 090	Snout, Corrugated, 1.25 Camlocks
BOP 030	Collet Block Assy
BOP 081-6	Tube, Snout, SS, 6in
BOP 084	Tube, Snout, Alum, 1.75 x 1.25
BOP 085	Hose Coupling, Alum, 1.25 NPT
BOP 090	Snout, Corrugated, 1.25 Camlocks
BOP 010-2-4-QTR	Quarter Plate Assy, 2in-4in
BT18-MP6R-A	Beetle Tube Spinner, 22k psi (8.5-11gpm)
BT25-MP6R-A	Banshee Tube Spinner, 22k psi (13-20gpm)
BT25-MP6R-C	Banshee Tube Spinner, 22k psi (12-15gpm)
ABX-PRO	AutoBox ABX-PRO Tractor Assy