

HIGH PRESSURE WATER SWIVEL

SL-H9H9

OPERATION AND MAINTENANCE MANUAL

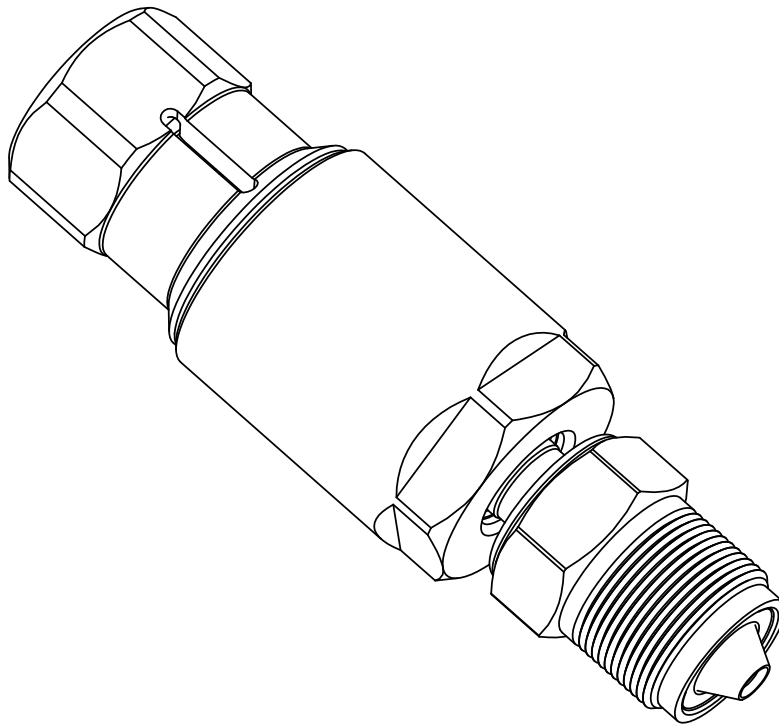

54 Girard St. Durango, Colorado 81303
www.stoneagetools.com

(970) 259-2869 Phone (970) 259-2868 Fax
sales@stoneagetools.com

TABLE OF CONTENTS

1.0	INTRODUCTION
2.0	SAFETY WARNING
3.0	DESCRIPTION
4.0	PARTS LIST
5.0	ASSEMBLY DRAWING
6.0	MAINTENANCE
7.0	WARRANTY

1.0 INTRODUCTION

This manual was prepared to provide the operator with the basic information needed to operate and service this equipment. The operating recommendations in the manual will ensure that you receive satisfactory performance. All operating personnel responsible for the care of this equipment should be familiar with the information in this manual.

If you have any questions or problems with this equipment, please contact the distributor you obtained the product from, or the manufacturer:

StoneAge, Inc.
54 Girard St.
Durango, CO 81303
970-259-2869 Phone 970-259-2868 Fax
www.stoneagetools.com

2.0 SAFETY WARNING

Operations with this equipment can be potentially dangerous if caution is not exercised prior to and during tool use. Please read and follow all of these instructions, in addition to the guidelines in the WJTA Recommended Practices handbook.

- 2.1 Only competent and trained persons should operate this equipment.
- 2.2 Do not exceed the maximum operating pressure specified for any component in a system.
- 2.3 This equipment should always be used with an operator controlled dump mechanism to release the high pressure water.
- 2.4 The immediate work area should be marked off to keep out untrained persons.
- 2.5 All personnel in the area should wear eye and hearing protection, as well as other protective clothing in accordance with specific conditions.
- 2.6 Inspect the equipment for visible signs of deterioration, damage, or improper assembly. Do not operate until repaired. Make sure all threaded connections are tight and leak free.
- 2.7 Check to see that all control functions work properly before going to high pressure.
- 2.8 If it is necessary to have a person work near the cleaning jets, then it is this person who should have direct control of the pressure dump mechanism.

3.0 DESCRIPTION

The **SL-H9H9** swivel was designed to be a versatile, compact union for use in conveying high pressure fluid from a stationary line to a rotating or twisting assembly. Due to the unique seal design, the torque necessary to rotate the swivel is relatively small, even at high pressures. This swivel should not be used as a self-rotating tool (rotated by waterjet thrust) as it does not have any type of speed control.

The SL-H9H9 has a straight flow through design with a leak free high pressure seal, so no pump power is wasted. The high pressure seal can be expected to last a minimum of 40 to 60 hours, and is simple to replace. The tool can be used at operating pressures from 5000 to 40,000 psi and flow rates from 4 to 12 gpm. The tool has a **9/16 high pressure autoclave** female inlet, a **9/16 high pressure autoclave** male outlet. It is recommended that the swivel be installed such that flow is from the female inlet to the male outlet. Flow in this direction will result in maximum seal life.

4.0 PARTS LIST

<u>Part #</u>	<u>Description</u>	<u>Qty</u>
AF 071-H9	Collar	1
AF 072-H9	Gland Nut & Collet	1
BC 009	Bearing	1
BC 120-C	Seal Holder	1
BC 122	Inlet Seat	1
BC 123	O-Ring	1
BC 318	Washer	1
FT 011-UH	Carbide Seat	1
FT 012-TO	High Pressure Seal	1
GO 302	Inlet Nut	1
MT 010	Shaft Seal	1
RJ 007	Bearing	2
RJ 029	Shaft Seal	1
SL 003	Body	1
SL 401	Shaft	1
SL 404	Spacer	1

Also available separately:

AF 073-H9	Coupling	(H9-H9 Coupling)
BC 602-UH	Seal Kit	(Includes parts needed for one seal change)
SL 610-H	Overhaul Kit	(Includes parts needed for tool rebuild)
GO 612	Tool Kit	(Includes tools to aid assembly)

SL-H9H9 EXPLODED ASSEMBLY DRAWING

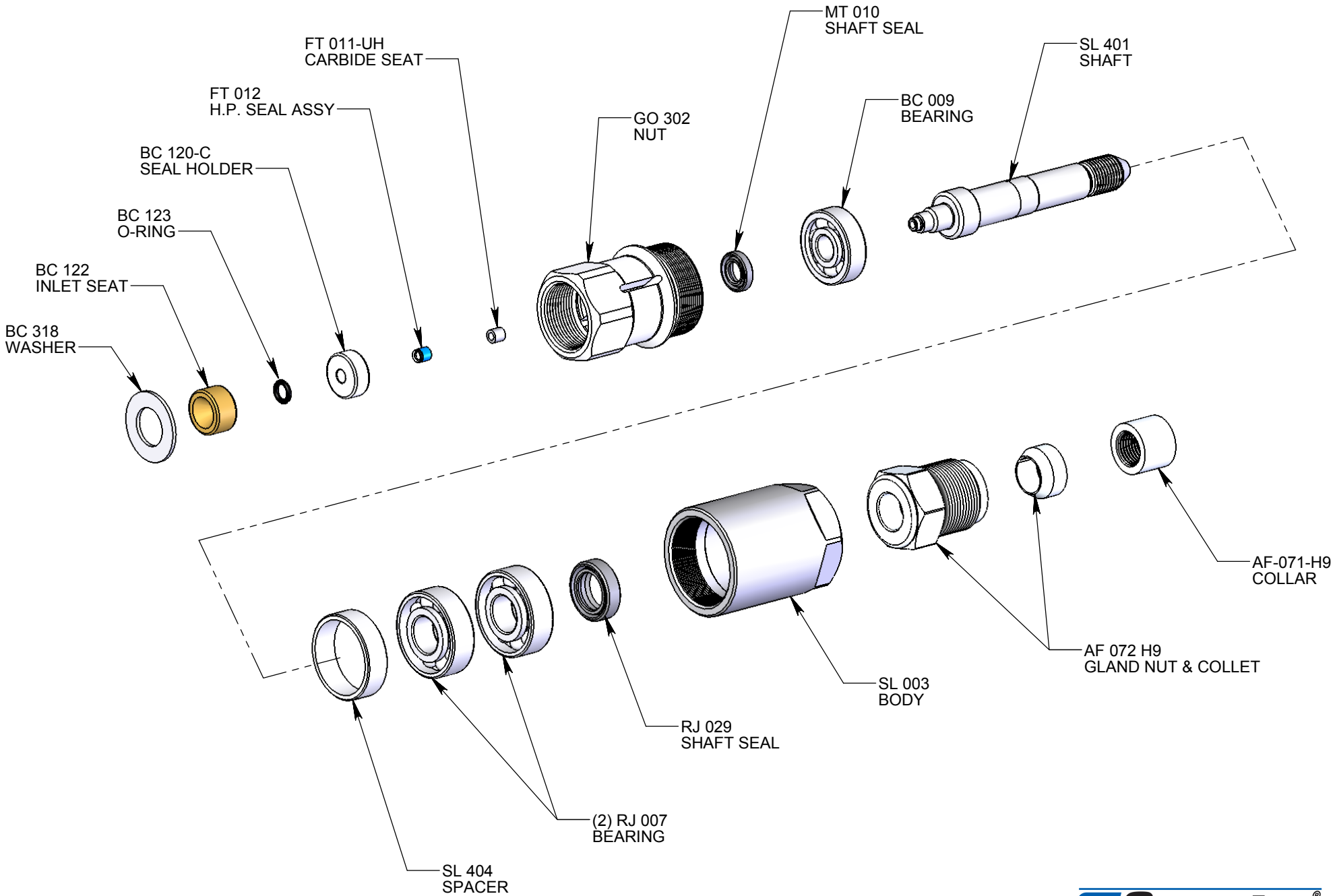

6.0 SL-H9H9 HIGH PRESSURE SEAL MAINTENANCE

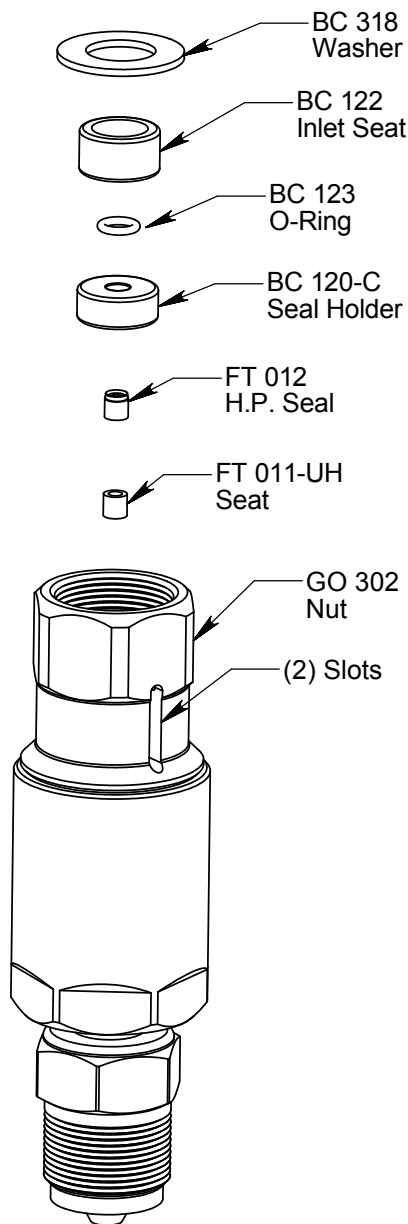

To replace the high pressure seal:

1. Remove the Washer (BC 318) from inlet port. It is easiest to push it upward from the top of the slot.
2. Use two picks inserted thru the slots to pry the Seal Holder (BC 120-C) and Inlet Seat (BC 122) up and out of the Nut.
3. Remove the H.P. Seal (FT 012) and Carbide Seat (FT 011-UH). Inspect the Seal Holder for grooves. If it is badly grooved on one end, it can be flipped over or replaced.
4. Inspect Carbide Seat (FT 011-UH) for chips or erosion. Replace if damaged. Inspect end of shaft for dings.
5. Check that O-Ring (BC 123) is in groove of Inlet Seat (BC 122). Place Seal Holder (BC 120-C) on top of Inlet Seat (against the side with the O-Ring).
6. Apply grease to a new H.P. Seal and install in Seal Holder. The end with the O-Ring and metal cone faces away from the Carbide Seat. Apply grease to the face of the Carbide Seat and install against H.P. Seal.
7. Balance the Inlet Seat and Seal Holder on fingertip; turn swivel upside down (H9 Coupling up) and slide the Inlet Seat and Seal Holder into the Nut. Make certain that the Carbide Seat stays in Seal Holder.
8. Turn the swivel inlet end up; the Inlet Seat and Seal Holder should be far enough into Nut to install the Washer (BC 318) into the groove below the inlet threads.

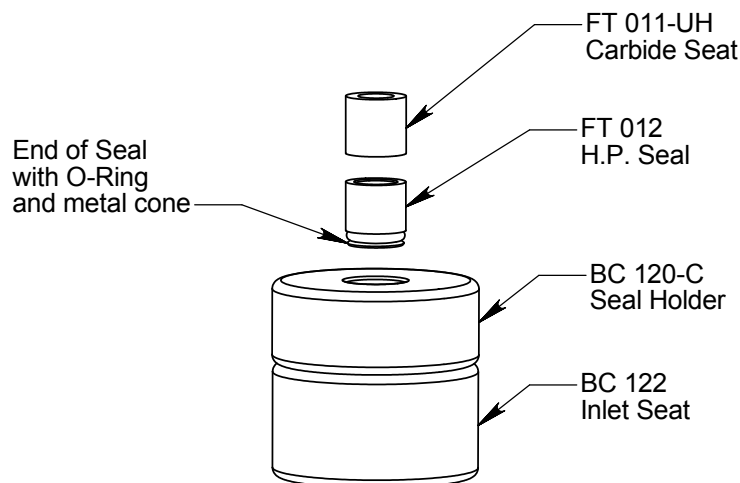

6.1 SL-H9H9 DISASSEMBLY INSTRUCTIONS

1. Remove the Washer (BC 318) from the inlet port of the Nut. Pry out the Seal Holder (BC 120-C) and Inlet Seat (BC 122) as explained in Section 6.0.

2. Unscrew the Nut (GO 302) from the Body (SL 003).

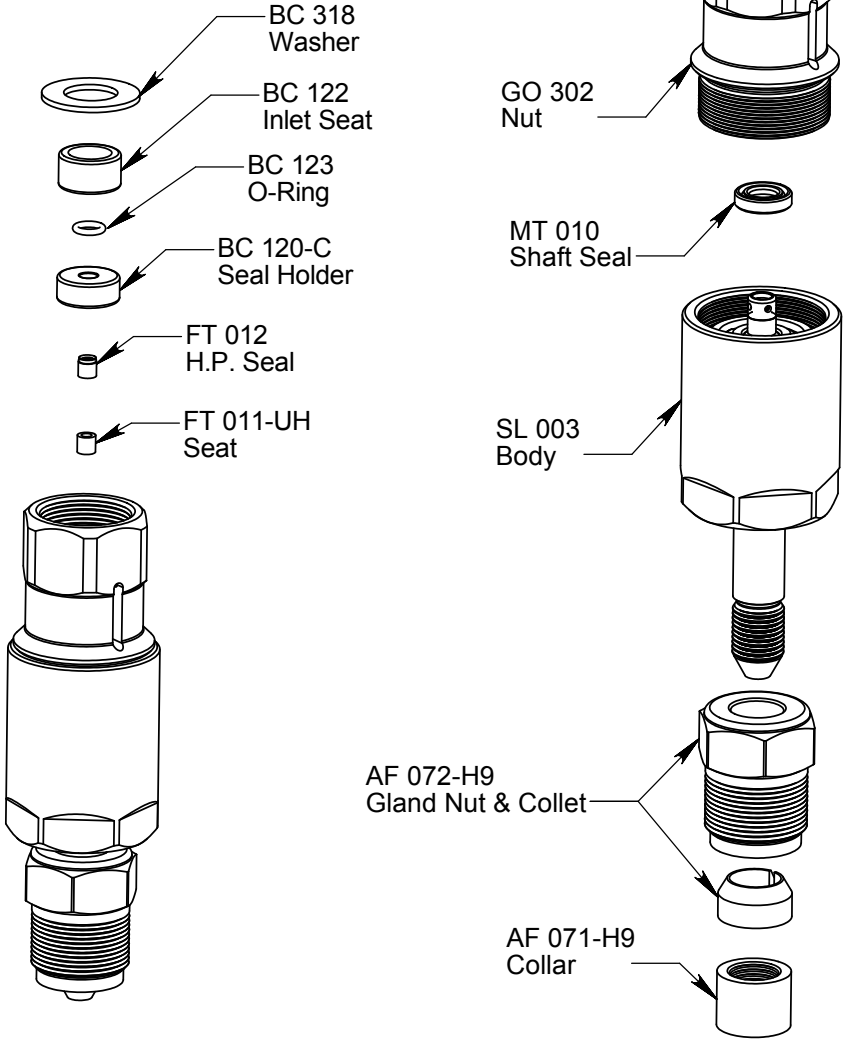

3. If the Shaft Seal (MT 010) is damaged, remove it from the Nut using snap ring pliers.

4. Remove the Coupling (AF 073-H9), Gland Nut & Collet (AF-072-H9), and Collar (AF-71-H9).

5. Remove the Shaft (SL 401), Bearings, and Spacer (SL 404) from the Body.

6. Remove the Spacer.

7. Remove the Bearings (BC 009, (2) RJ 007), and from the Shaft.

8. If the Shaft Seal (RJ 029) is damaged, remove it from the Body and replace.

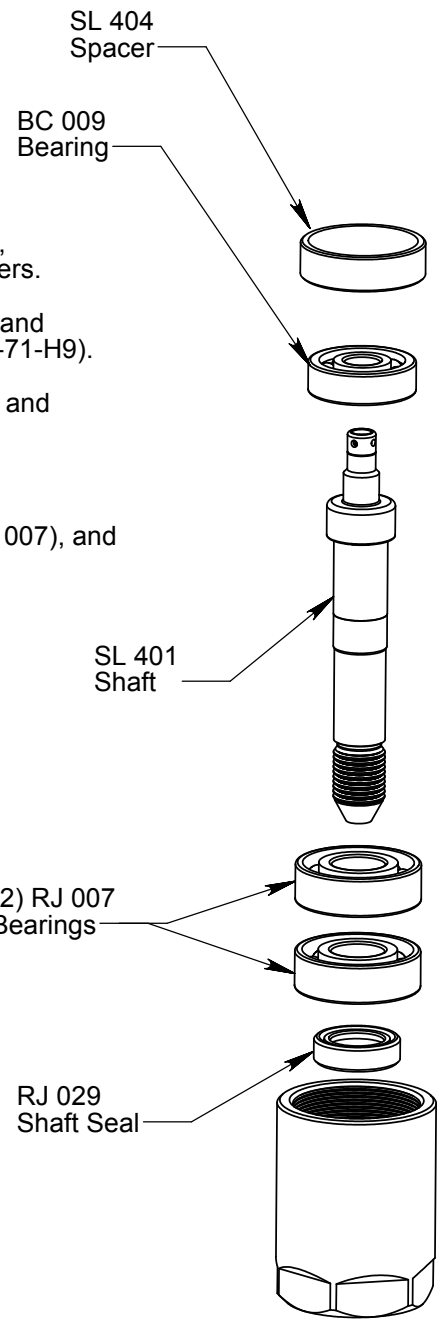

6.2 SL-H9H9 ASSEMBLY INSTRUCTIONS

1. If Shaft Seal (RJ 029) was damaged or removed, replace with a new one. Install in the Body (SL 003) with lip facing up as shown. Apply grease or Armour All to lip of seal.

2. Install Bearing (BC 009) on small end of the Shaft (SL 401). Grease pack bearing.

3. Install Bearings (2 X RJ 007) on Shaft (SL 401). These bearings are angular contact and need to be installed as shown. Grease pack bearings.

4. Install Shaft and Bearings into Body (SL 003).

5. Slide Spacer into body over BC 009 Bearing.

6. If Shaft Seal (MT 010) was damaged or removed, replace with a new one. Install in the Nut (GO 302) with lip facing up as shown. Apply grease or Armour All to lip of seal.

7. Apply anti-sieze to threads of Nut; thread into Body. Tighten to 40 ft-lb.

8. Install the Gland Nut & Collet (AF-072-H9), Collar (AF-71-H9), and Coupling (AF 073-H9).

9. Install the high pressure seal components as shown in section 6.0

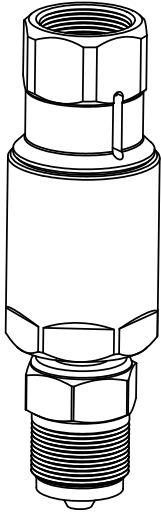
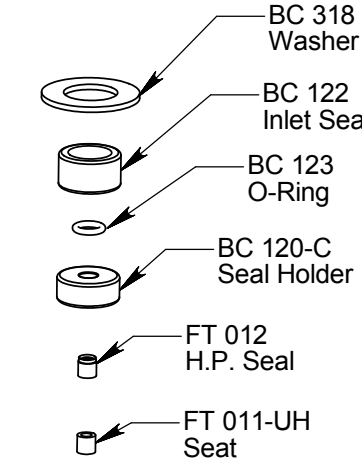
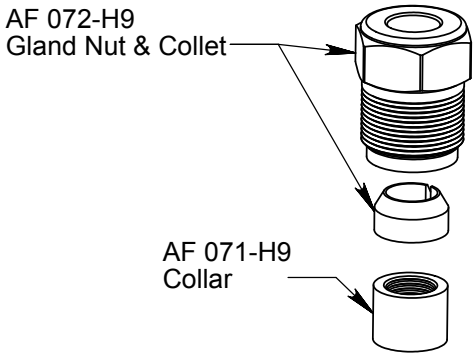
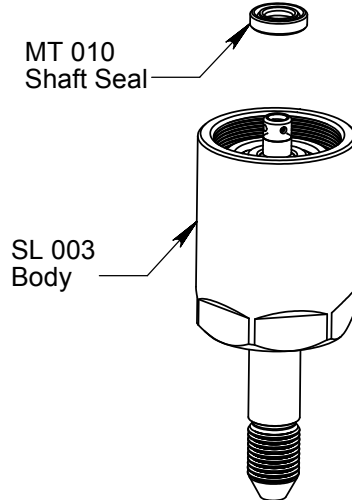
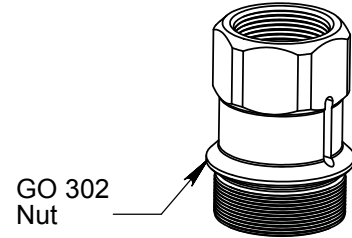
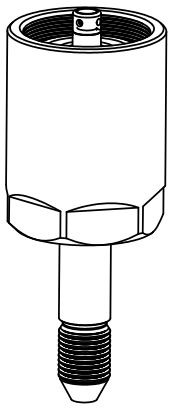
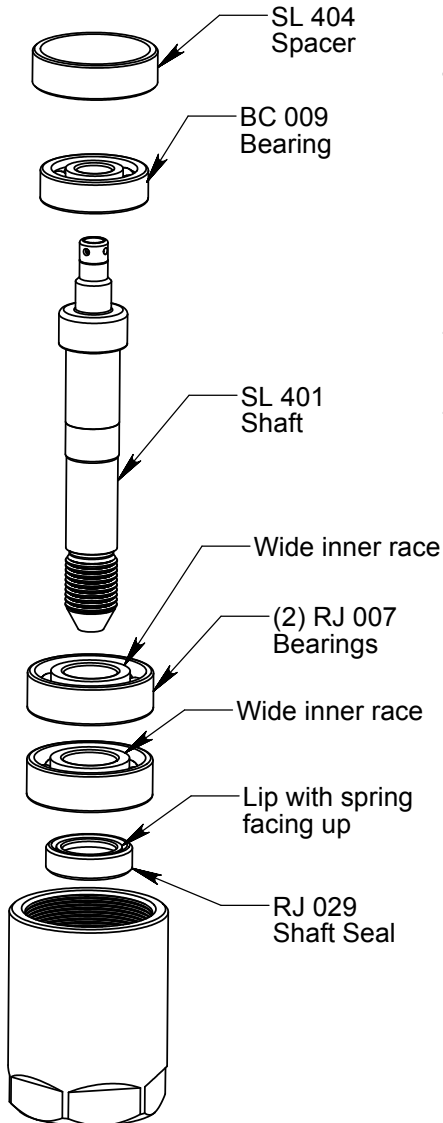

6.3 TROUBLESHOOTING GUIDE

<u>SYMPTOM</u>	<u>PROBLEM</u>	<u>SOLUTION</u>
Leaks out slots in Nut At high pressure	Loose inlet fitting Worn H.P. seal Eroded seat Damaged shaft end	Tighten inlet fitting Replace H.P. Seal (FT 012-TO) Replace Seat (FT 011-UH) Face or replace Shaft
Seals wear out quickly	Damaged seat Worn Seal Holder	Replace Seat (FT 011-UH) Replace Seal Holder (BC 120-C)
Will not rotate	Internal damage Bearings installed backwards	Inspect and repair Inspect and repair
Water inside tool	Bad H.P. Seal leak Worn shaft seals	Replace H.P. Seal Replace shaft seals

7.0 LIMITED WARRANTY

StoneAge, Inc. warrants to the extent herein provided the products of its own manufacture against defects in material and workmanship under normal use and service for which the products were designed for a period of six months after shipment from the factory. If such products should fail through defect in workmanship or material and specific written notice of failure is made within six months after date of shipment from factory, StoneAge, Inc. will either repair or replace any such items, F.O.B. its factory without charge. StoneAge, Inc. shall not be liable for expense incurred in repairs or alterations made outside the factory without the proper and prior authorization. StoneAge, Inc. shall have the option of requiring the return of the defective products to its factory, with transportation charges prepaid, to establish the claim. StoneAge, Inc. shall in no event be held liable for damages or delay resulting from or arising out of defective products nor for consequential damages or otherwise except for repair or replacement of items of defective material or workmanship aforesaid.

THIS WARRANTY IS EXPRESSLY IN LIEU OF ALL OTHER WARRANTIES EXPRESSED OR IMPLIED INCLUDING THE WARRANTIES OF MERCHANTABILITY AND FITNESS FOR USE AND NEITHER ASSUMES, NOR AUTHORIZES ANY PERSON TO ASSUME FOR STONEAGE, INC. ANY OTHER LIABILITY IN CONNECTION WITH THE SALE OF ITS PRODUCTS. THIS WARRANTY SHALL NOT APPLY TO PRODUCTS OR ANY PARTS THEREOF WHICH HAVE BEEN SUBJECT TO ACCIDENT, NEGLIGENCE, ALTERATION, ABUSE, OR MISUSE. STONEAGE, INC. MAKES NO WARRANTY WHATSOEVER IN RESPECT TO ACCESSORIES, PARTS OR PRODUCTS NOT MANUFACTURED BY STONEAGE, INC.