

ROTARY WATERBLAST NOZZLE

RJV

OPERATION AND MAINTENANCE MANUAL

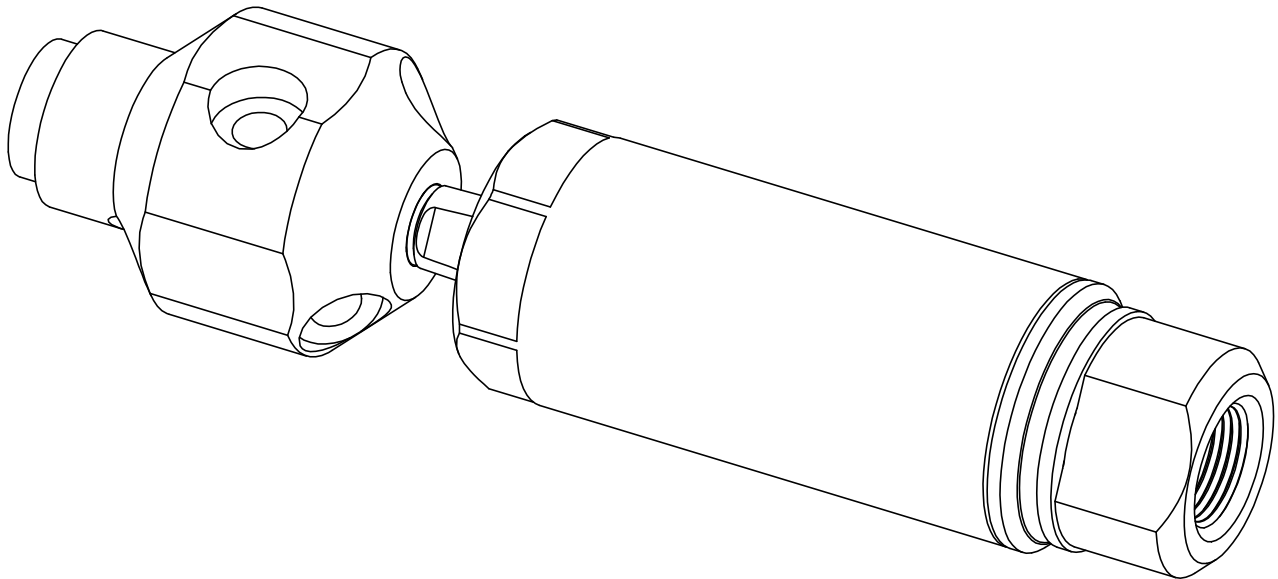

54 Girard St. Durango, Colorado 81303
www.stoneagetools.com

(970) 259-2869 Phone (970) 259-2868 Fax
sales@stoneagetools.com

TABLE OF CONTENTS

1.0	INTRODUCTION
2.0	SAFETY WARNING
3.0	DESCRIPTION
4.0	PARTS LIST
5.0	ASSEMBLY DRAWING
6.0	MAINTENANCE
7.0	WARRANTY
	APPENDIX
	A. Viscous Fluid Material Safety Data Sheet

1.0 INTRODUCTION

This manual was prepared to provide the operator with the basic information needed to operate and service this equipment. The operating recommendations in the manual will ensure that you receive satisfactory performance. All operating personnel responsible for the care of this equipment should be familiar with the information in this manual.

If you have any questions or problems with this equipment, please contact the distributor you obtained the product from, or the manufacturer:

StoneAge, Inc.
54 Girard St.
Durango, CO 81303
970-259-2869 Phone 970-259-2868 Fax
www.stoneagetools.com

2.0 SAFETY WARNING

Operations with this equipment can be potentially dangerous if caution is not exercised prior to and during tool use. Please read and follow all of these instructions, in addition to the guidelines in the WJTA Recommended Practices handbook.

- 2.1 Only competent and trained persons should operate this equipment.
- 2.2 The immediate work area should be marked off to keep out untrained persons.
- 2.3 All personnel in the area should wear appropriate personal protective equipment.
- 2.4 Inspect the equipment for visible signs of deterioration, damage, or improper assembly. Do not operate until repaired. Make sure all threaded connections are tight and leak free.
- 2.5 Check nozzle orifices before use. If any are plugged, they must be cleaned or replaced.
- 2.6 This equipment should always be used with an operator controlled dump mechanism to release the high pressure water. If it is necessary to have a person work near the cleaning jets, then it is this person who should have control of the pressure dump.
- 2.7 Check that all control functions work properly before going to high pressure.
- 2.8 The tool should be securely supported. Strong thrust is created by waterjets and these forces can become unbalanced if a nozzle should become plugged. The use of a backout prevention device is recommended.
- 2.9 The length of the tool and end fitting on hose should be equal to or greater than the inside diameter of the pipe to be cleaned. If not, use pipe between the hose end and the tool.
- 2.10 Do not exceed the maximum operating pressure specified for any component in a system.
- 2.11 Avoid operator/personnel positioning in possible path of out of control tool.

3.0 DESCRIPTION

The **RJV** Rotary Waterblast Nozzle was designed for waterblast cleaning of pipes, tanks, vessels and surfaces. Jet reaction force makes the tool rotate, and a built in viscous fluid governor controls the rotation speed. The tool is constructed of stainless steel for corrosion resistance.

The swivel is a straight flow through design with a single high pressure seal. It has a 1/2 npt female inlet connection. The RJV is capable of working pressures up to 15000 psi and flow rates of 5 to 35 gpm. Two rotation speed ranges are available; a thick fluid is used for rotation speeds of 10 to 100 rpm, and a thinner fluid is used for rotation speeds of 50 to 250 rpm. The fluid in the swivel can be changed to provide either fast or slow rotation.

The correct nozzle head must be used to match the operating conditions of pressure and flow. If a nozzle head with too little offset is used, the swivel will not rotate; if a head with too much offset is used, the tool will rotate too fast and cause rapid seal wear and failure. See the chart below for head selection.

<u>Head Offset</u>	<u>Flow</u>
.30	5 to 10 gpm
.15	10 to 20 gpm
.08	20 to 35 gpm

4.0 PARTS LIST

<u>Part #</u>	<u>Description</u>	<u>Qty</u>
DT 032	Retaining Ring	1
RJ 001-SR	Shaft	1
RJ 002-P8	Inlet Nut	1
RJ 003	Body	1
RJ 007	Bearing, Angular Contact	1
RJ 008	O-Ring	1
RJ 009	Bearing	1
RJ 010	Shaft Seal	1
RJ 011	Seat	1
RJ 012-TO	High Pressure Seal	1
RJ 013	Spring	1
RJ 014	Wave Spring	1
RJ 015	Washer	1
RJ 021-S	Weep Seal	1
RJ 028	Piston	1
RJ 029	Shaft Seal	1
RJ 030	O-Ring	1

Also available separately:

RJ 600	Service Kit	(Includes items needed for maintenance)
RJ 602	Seal Kit	(Includes parts needed for one seal change)
RJ 610	Overhaul Kit	(Includes parts needed for tool rebuild)
RJ 612	Tool Kit	(Includes tools to aid assembly)

RJV EXPLODED ASSEMBLY DRAWING

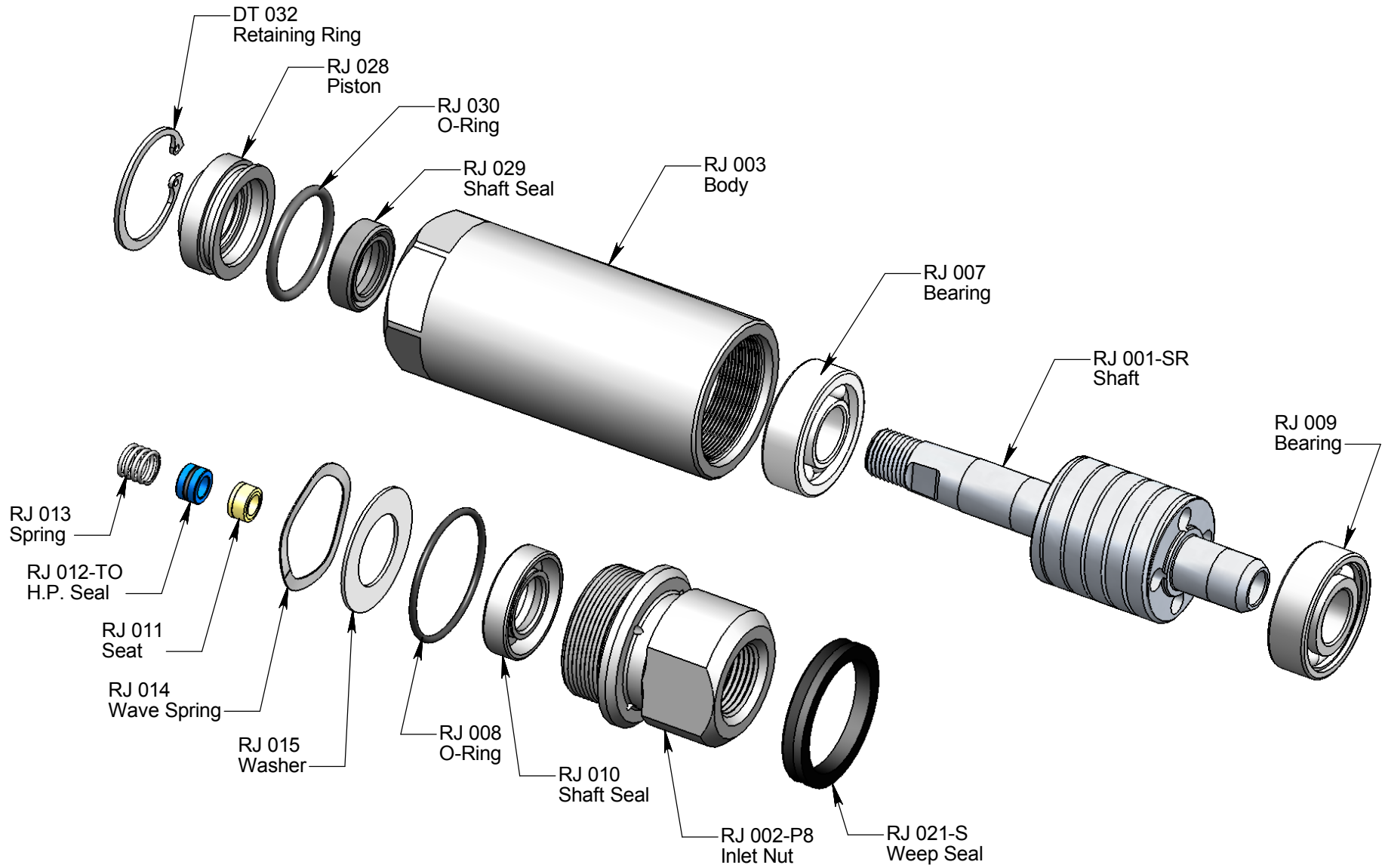

6.0 RJ HIGH PRESSURE SEAL MAINTENANCE

The most important item in maintaining this swivel is keeping the tool full of viscous fluid, which provides lubrication and speed control. The viscous fluid should be checked when the tool begins to run faster than usual, and during high pressure seal replacement. If the fluid appears contaminated, it should be drained and replaced.

The high pressure seal should be replaced when there is a continuous leak at operating pressure from under the Weep Seal (RJ 021-S) around the Inlet Nut.

To replace the high pressure seal:

1. Unscrew the Inlet Nut (RJ 002-P8) from the Body.
2. Pull out the Seat (RJ 011), H.P. Seal (RJ 012-TO) and Spring (RJ 013) from the bore of Shaft.
3. Inspect the bore of the Shaft; if it is badly grooved it should be replaced.
4. Inspect the face of the Inlet Nut where the Seat makes contact; if it is pitted or dented, it should be faced or replaced.
5. Install Spring (RJ 013) into bore of Shaft.
6. Apply grease to a new H.P. Seal and push into bore of Shaft.
7. Place a new Seat (RJ 011) on top of H.P. Seal; the flat face of the Seat goes against the seal (see detail).
8. Apply anti-seize to threads of Inlet Nut and thread into Body; make sure the Seat stays in bore of Shaft. Tighten to 50 ft-lb.

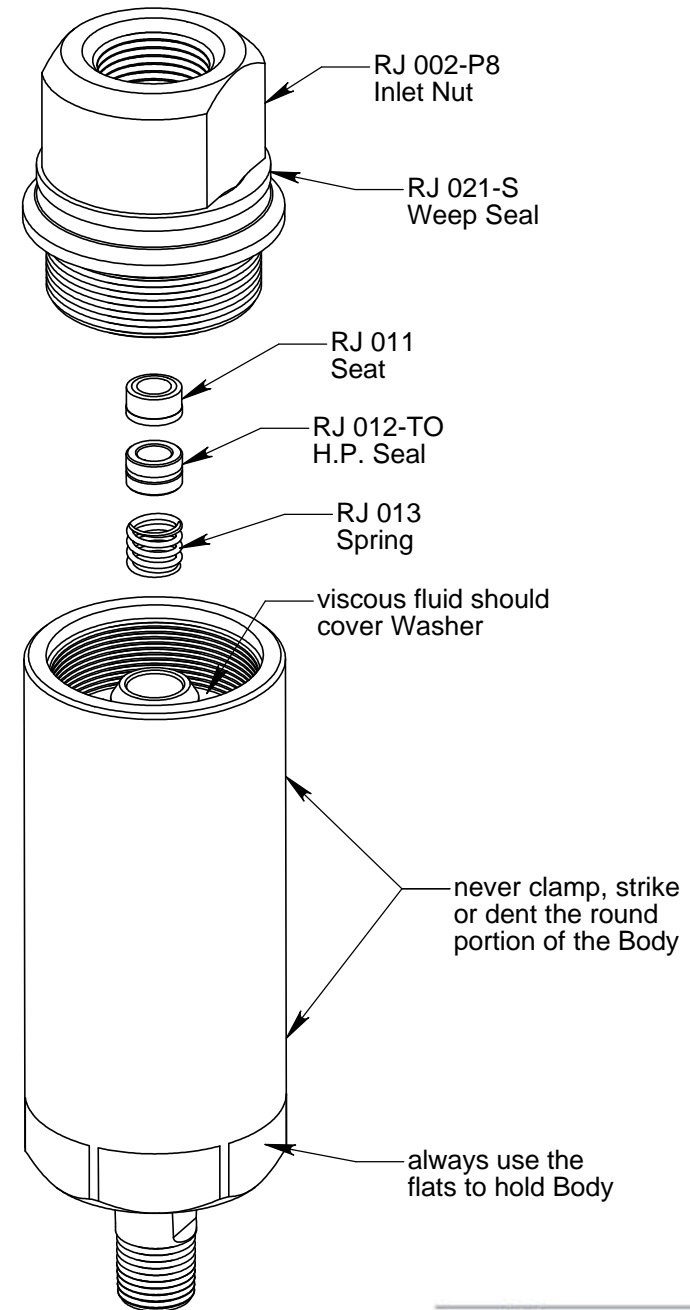
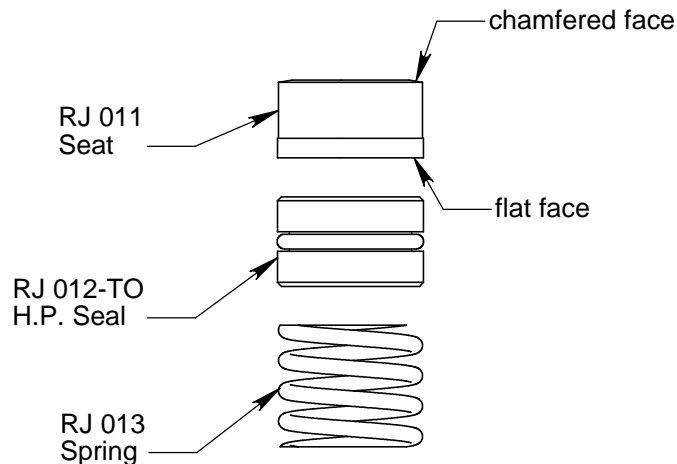

6.1 RJ DISASSEMBLY INSTRUCTIONS

1. Unscrew the Inlet Nut (RJ 002-P8) from the Body (RJ 003).
2. Lift out the Washer (RJ 015) and Wave Spring (RJ 014).
3. Pull out the Seat (RJ 011), H.P. Seal (RJ 012-TO) and Spring (RJ 013).

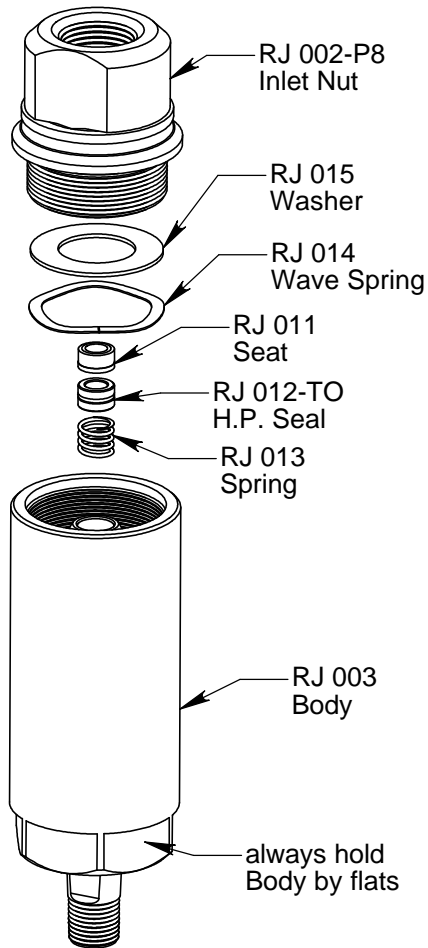

4. Push the Shaft (RJ 001-SR) with bearings out of the Body.
5. Carefully remove Bearings (RJ 009, RJ 007) from the Shaft.

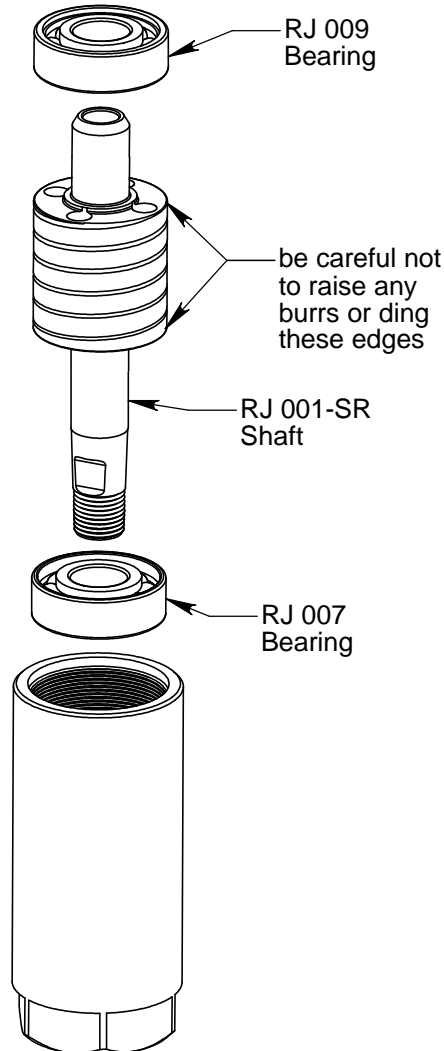

6. Remove the Retaining Ring (DT 032) from the Body.
7. Push out the Piston (RJ 028).
8. The Shaft Seal (RJ 029) and O-Ring (RJ 030) can be removed from the Piston if they need to be replaced.

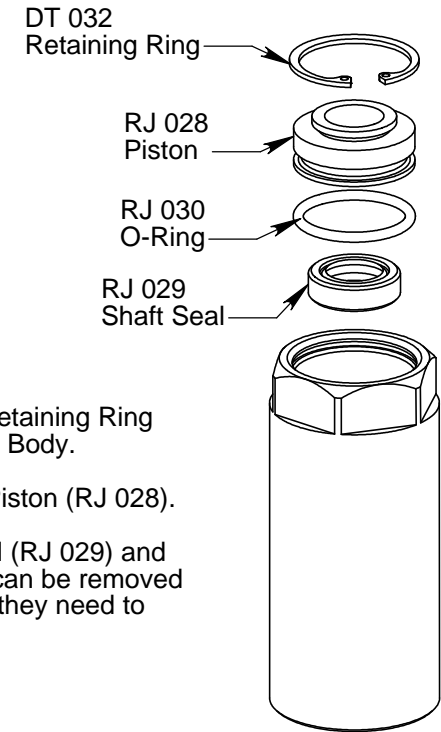

9. The Shaft Seal (RJ 010) can be removed from the Inlet Nut if it needs to be replaced.
10. Remove the O-Ring (RJ 008) and Weep Seal (RJ 021-S) from the Inlet Nut.

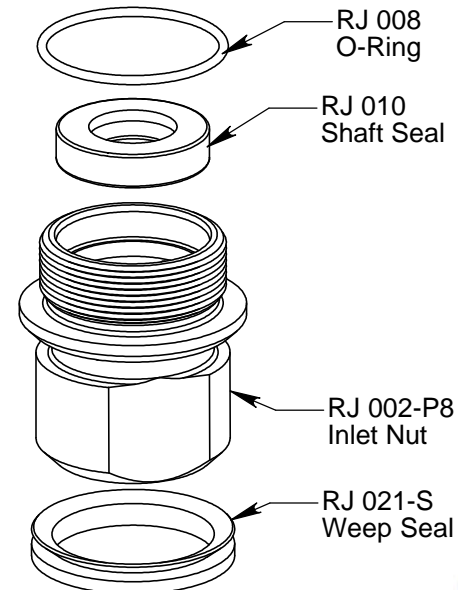

6.2 RJ ASSEMBLY INSTRUCTIONS

1. Install Shaft Seal (RJ 029) in Piston (RJ 028) as shown.
2. Place O-Ring (RJ 030) in groove around Piston.
3. Install Piston in Body (RJ 003); install Retaining Ring (DT 032).

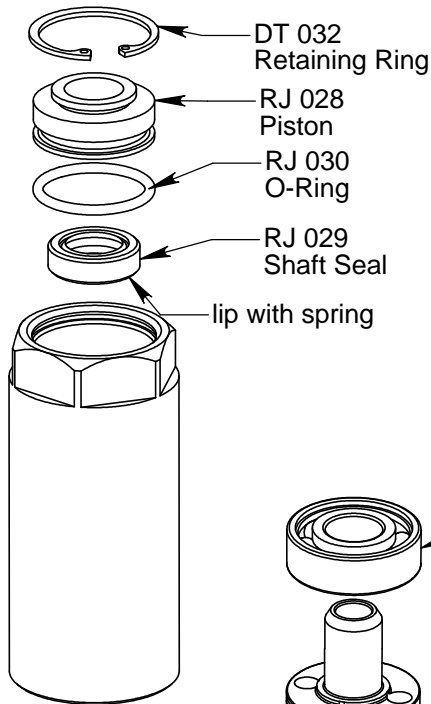

4. Install Shaft Seal (RJ 010) in Inlet Nut (RJ 002-P8) as shown.
5. Place O-Ring (RJ 008) over threads of Inlet Nut.
6. Install Weep Seal (RJ 021-S) in groove around Inlet Nut.

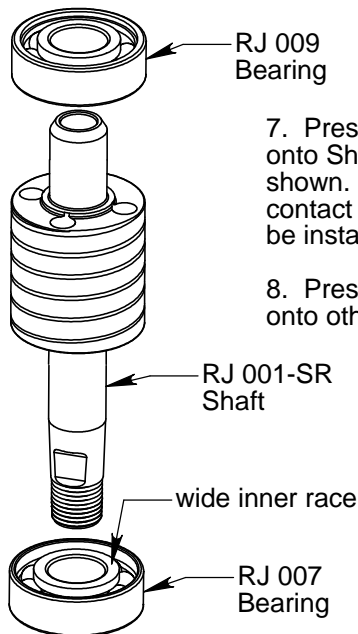
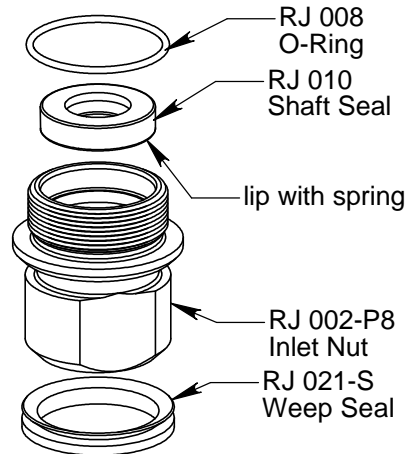

7. Press Bearing (RJ 007) onto Shaft (RJ 001-SR) as shown. This is an angular contact bearing and must be installed correctly.

8. Press Bearing (RJ 009) onto other end of Shaft.

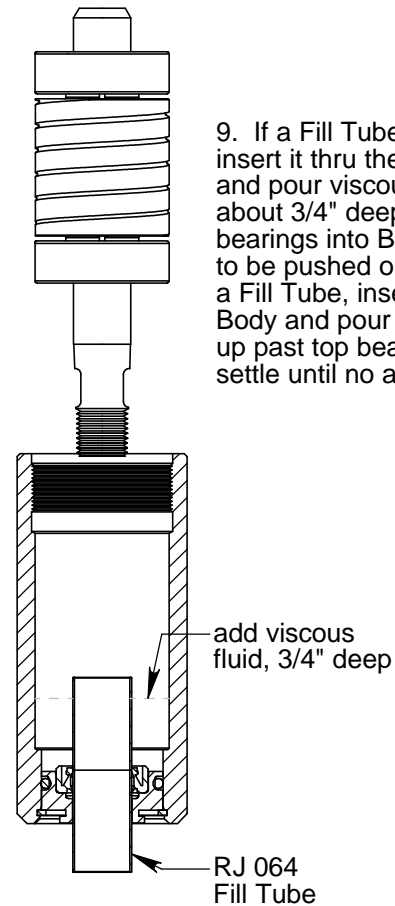

9. If a Fill Tube (RJ 064) is available, insert it thru the shaft seal in Piston and pour viscous fluid into Body until about 3/4" deep. Insert the Shaft with bearings into Body, allowing Fill Tube to be pushed out. If you do not have a Fill Tube, insert the Shaft into the Body and pour viscous fluid in to fill up past top bearing. Allow fluid to settle until no air bubbles come out.

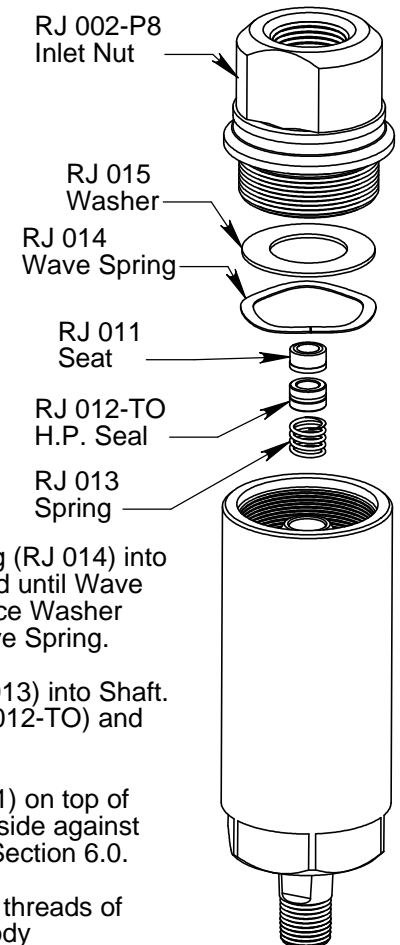

10. Place Wave Spring (RJ 014) into Body. Add viscous fluid until Wave Spring is covered. Place Washer (RJ 015) on top of Wave Spring.

11. Insert Spring (RJ 013) into Shaft. Grease H.P. Seal (RJ 012-TO) and push into Shaft.

12. Place Seat (RJ 011) on top of H.P. Seal, with the flat side against the Seal, as shown in Section 6.0.

13. Apply anti-seize to threads of Inlet nut, thread into Body and tighten to 50 ft-lb.

6.3 TROUBLESHOOTING GUIDE

<u>SYMPTOM</u>	<u>PROBLEM</u>	<u>SOLUTION</u>
Leaks around weep seal	Worn H.P. seal Damaged seat Damaged Inlet Nut	Replace H.P. Seal (RJ 012-TO) Replace Seat (RJ 011) Face or replace Inlet Nut
Seals wear out quickly	Worn seat Worn Shaft bore	Replace Seat (RJ 011) Replace Shaft if bore >.385"
Will not rotate	Not enough jet torque Improper Assembly Internal damage	Check nozzles for plugging or wear. Check that head offset correctly matches pressure and flow. Check bearing (RJ 007) is installed correctly Rotate head by hand, if rough to turn, check bearings; check grooved section of shaft for contact with body.
Water inside tool	Bad H.P. Seal leak Worn shaft seals	Replace H.P. Seal Replace shaft seals
Spins too fast	Low or empty viscous fluid Water in viscous fluid Too much jet torque Wrong viscous fluid	Refill with viscous fluid. Clean and refill viscous fluid. Check that head offset matches pressure and flow. Replace with slow fluid.

7.0 LIMITED WARRANTY

StoneAge, Inc. warrants to the extent herein provided the products of its own manufacture against defects in material and workmanship under normal use and service for which the products were designed for a period of six months after shipment from the factory. If such products should fail through defect in workmanship or material and specific written notice of failure is made within six months after date of shipment from factory, StoneAge, Inc. will either repair or replace any such items, F.O.B. its factory without charge. StoneAge, Inc. shall not be liable for expense incurred in repairs or alterations made outside the factory without the proper and prior authorization. StoneAge, Inc. shall have the option of requiring the return of the defective products to its factory, with transportation charges prepaid, to establish the claim. StoneAge, Inc. shall in no event be held liable for damages or delay resulting from or arising out of defective products nor for consequential damages or otherwise except for repair or replacement of items of defective material or workmanship aforesaid.

THIS WARRANTY IS EXPRESSLY IN LIEU OF ALL OTHER WARRANTIES EXPRESSED OR IMPLIED INCLUDING THE WARRANTIES OF MERCHANTABILITY AND FITNESS FOR USE AND NEITHER ASSUMES, NOR AUTHORIZES ANY PERSON TO ASSUME FOR STONEAGE, INC. ANY OTHER LIABILITY IN CONNECTION WITH THE SALE OF ITS PRODUCTS. THIS WARRANTY SHALL NOT APPLY TO PRODUCTS OR ANY PARTS THEREOF WHICH HAVE BEEN SUBJECT TO ACCIDENT, NEGLIGENCE, ALTERATION, ABUSE, OR MISUSE. STONEAGE, INC. MAKES NO WARRANTY WHATSOEVER IN RESPECT TO ACCESSORIES, PARTS OR PRODUCTS NOT MANUFACTURED BY STONEAGE, INC.

APPENDIX BJ 048-S VISCOUS FLUID

OSI SPECIALTIES INC — POLYDIMETHYLSILOXANE L-405-12500
MATERIAL SAFETY DATA SHEET Revision: 1.0 9/27/2000

MSDS Safety Information

MSDS Date: 9/27/2000
MSDS Num: 91000000791
Product ID: L-405-12500
Chemical Name: Polydimethylsiloxane(inhibited)
Responsible Party: Mr. Dana Dalrymple
Name: OSI SPECIALTIES INC
Address: ONE AMERICAN LANE
City: GREENWICH CT 06831-2559
Info Phone Number: 304-652-8446
Emergency Phone Number: 800-809-9998; 800-424-9300(CHEMTREC)
Published: Y

Ingredients

Proprietary: NO
Ingredient: POLYDIMETHYLSILOXANE
Ingredient Sequence Number: 01
Percent: <100%
CAS Number: 63148-62-9
Other Recommended Limit: NONE SPECIFIED

Proprietary: NO
Ingredient: PROPRIETARY inhibitors
Ingredient Sequence Number: 02
Percent: <1%
Trade secret

Health Hazards Data

LD50-LC50 Mixture: LD50 (ORAL RAT) IS UNKNOWN
Route Of Entry - Inhalation: NO
Route Of Entry - Skin: NO
Route Of Entry - Ingestion: NO
Health Haz Acute And Chronic: ACUTE & CHRONIC: NO EVIDENCE OF ADVERSE FROM AVAILABLE INFORMATION.
Carcinogenicity - NTP: NO
Carcinogenicity - IARC: NO
Carcinogenicity - OSHA: NO
Signs/Symptoms Of Overexp: No Adverse Effects.
Med Cond Aggravated By Exp: None Specified By Manufacturer.
Emergency/First Aid Proc:
INGESTION: NO EMERGENCY CARE ANTICIPATED.
SKIN:WASH WITH SOAP AND WATER.
INHALATION: NO EMERGENCY CARE ANTICIPATED.
EYES: FLUSH THOROUGHLY WITH WATER FOR SEVERAL MINUTES.
NOTES TO PHYSICIAN: THERE IS NO SPECIFIC ANTIDOTE. TREATMENT OF OVEREXPOSURE SHOULD BE DIRECTED AT THE CONTROL OF SYMPTOMS AND THE CLINICAL CONDITION OF THE PATIENT

Handling and Disposal

Fire and Explosion Hazard Information

Flash Point: 254°C/(490°F)
Extinguishing Media: DO NOT SPRAY A SOLID STREAM OF WATER DIRECTLY INTO BURNING LIQUID.
USE CARBON DIOXIDE, ALCOHOL FOAM, OR DRY CHEMICAL.
Special Fire Fighting Proc: WEAR SELF CONTAINED BREATHING APPARATUS.
CONTAIN RUNOFF.
Unusual Fire And Expl Hazrds: MAY CAUSE FLOATING FIRE HAZARD

Control Measures

Respiratory Protection: NONE EXPECTED TO BE REQUIRED.
Protective Gloves: 4H, BUTYL, NEOPRENE, NITRILE(NBR), PVC COATED
Eye Protection: SAFETY GLASSES
Work Hygienic Practices: OBSERVE GOOD PERSONAL HYGIENE PRACTICES AND RECOMMENDED PROCEDURES. DO NOT WEAR CONTAMINATED CLOTHING OR FOOTWEAR.
Other Protective Equipment: SAFETY SHOWER, EYE BATH

Physical/Chemical Properties

=====
Appearance:
Physical state: Clear to Hazy Liquid
Color: Yellow
Odor: Mild
Other Properties:
Boiling Point: >250°C @STP unless specified below
Melting Point: <-50°C @ STP unless specified below
pH: N/A
Spec Gravity: 0.9738@25°C
Vapor Pres: <1.33hPa (1.00mmHg) @20°C
Vapor Density: Heavier Than Air
Solubility in Water: Insoluble
Evaporation Rate: <1
Flash Point: >254°C / >490°F
Upper Explosion Limit: N/A
Lower Explosion Limit: N/A
Percent Volatile: Not Determined
Molecular Weight: Polymer
=====

Reactivity Data

=====
Stability: Stable
Stability Condition To Avoid: None Known.
Materials To Avoid: Strong oxidizing agents
Hazardous Combustion Products:
Burning Can Produce The Following Combustion Products:
OXIDES OF CARBON, OXIDES OF SILICON, FORMALDEHYDE, CARBON MONOXIDE IS
HIGHLY TOXIC IF INHALED; CARBON DIOXIDE IN SUFFICIENT CONCENTRATIONS CAN
ACT AS AN ASPHYXIANT.
ACUTE OVEREXPOSURE TO THE PRODUCTS OF COMBUSTION MAY RESULT IN
IRRITATION OF THE RESPIRATORY TRACT.
Hazardous Polymerization: Will Not Occur.
Conditions To Avoid Polymerization: None Known.
=====

Toxicological Information

=====
No information relevant to human health hazard evaluation is currently available
=====

Ecological Information

=====
Prevent Runoff
Use Absorbent To Clean Up
=====

MSDS Transport Information

=====
This product is not regulated by the DOT, IMDG, ICAO.
Freight description road: OIL, O/T PETROLEUM, LUBRICATING, NOIBN
=====

Regulatory Information

=====
CERCLA; None
SARA; None
MSL; None
EPA; None
California Prop 65; None
California SCAQMD; VOC=>0.5mmHg@ 104°C / 219.2°F **Not determined**
=====

Other Information

=====
Chemical Inventory
Europe: The ingredients of this mixture are on the EINECS inventory.
United States: The ingredients of this product are listed on the TSCA
inventory or are exempt.
=====

HAZCOM Label

=====
Product ID: POLYDIMETHYLSILOXANE L-45-12500
Supplier: Crompton Corporation
Street: One American Lane
City: Greenwich, CT
Zipcode: 06831-2559, USA
Health Emergency Phone: 800-809-9998;800-424-9300(CHEMTREC)
Label Required: Yes
Health Hazard: 0
Flammability: 1
Reactivity: 0
PPE: X
=====

APPENDIX BJ O48-F VISCOUS FLUID

OSI SPECIALTIES INC — POLYDIMETHYLSILOXANE L-405-2000
MATERIAL SAFETY DATA SHEET Revision: 1.0 9/27/2000

MSDS Safety Information

MSDS Date: 9/27/2000
MSDS Num: 491
Product ID: L-405-2000
Chemical Name: Polydimethylsiloxane(inhibited)
Responsible Party: Mr. Dana Dalrymple
Name: OSI SPECIALTIES INC
Address: ONE AMERICAN LANE
City: GREENWICH CT 06831-2559
Info Phone Number: 304-652-8446
Emergency Phone Number: 800-809-9998; 800-424-9300(CHEMTREC)
Published: Y

Ingredients

Proprietary: NO
Ingredient: POLYDIMETHYLSILOXANE
Ingredient Sequence Number: 01
Percent: <100%
CAS Number: 63148-62-9
Other Recommended Limit: NONE SPECIFIED

Proprietary: NO
Ingredient: PROPRIETARY inhibitors
Ingredient Sequence Number: 02
Percent: <1%
Trade secret

Health Hazards Data

LD50-LC50 Mixture: LD50 (ORAL RAT) IS UNKNOWN
Route Of Entry - Inhalation: NO
Route Of Entry - Skin: NO
Route Of Entry - Ingestion: NO
Health Haz Acute And Chronic: ACUTE & CHRONIC: NO EVIDENCE OF ADVERSE FROM AVAILABLE INFORMATION.
Carcinogenicity - NTP: NO
Carcinogenicity - IARC: NO
Carcinogenicity - OSHA: NO
Signs/Symptoms Of Overexp: No Adverse Effects.
Med Cond Aggravated By Exp: None Specified By Manufacturer.
Emergency/First Aid Proc:
INGESTION: NO EMERGENCY CARE ANTICIPATED.
SKIN:WASH WITH SOAP AND WATER.
INHALATION: NO EMERGENCY CARE ANTICIPATED.
EYES: FLUSH THOROUGHLY WITH WATER FOR SEVERAL MINUTES.
NOTES TO PHYSICIAN: THERE IS NO SPECIFIC ANTIDOTE. TREATMENT OF OVEREXPOSURE SHOULD BE DIRECTED AT THE CONTROL OF SYMPTOMS AND THE CLINICAL CONDITION OF THE PATIENT

Handling and Disposal

Fire and Explosion Hazard Information

Flash Point: 254°C/(490°F)
Extinguishing Media: DO NOT SPRAY A SOLID STREAM OF WATER DIRECTLY INTO BURNING LIQUID.
USE CARBON DIOXIDE, ALCOHOL FOAM, OR DRY CHEMICAL.
Special Fire Fighting Proc: WEAR SELF CONTAINED BREATHING APPARATUS.
CONTAIN RUNOFF.
Unusual Fire And Expl Hazrds: MAY CAUSE FLOATING FIRE HAZARD

Control Measures

Respiratory Protection: NONE EXPECTED TO BE REQUIRED.
Protective Gloves: 4H, BUTYL, NEOPRENE, NITRILE(NBR), PVC COATED
Eye Protection: SAFETY GLASSES
Work Hygienic Practices: OBSERVE GOOD PERSONAL HYGIENE PRACTICES AND RECOMMENDED PROCEDURES. DO NOT WEAR CONTAMINATED CLOTHING OR FOOTWEAR.
Other Protective Equipment: SAFETY SHOWER, EYE BATH

Physical/Chemical Properties

=====
Appearance:
Physical state: Clear to Hazy Liquid
Color: Yellow
Odor: Mild
Other Properties:
Boiling Point: >250°C @STP unless specified below
Melting Point: <-50°C @ STP unless specified below
pH: N/A
Spec Gravity: 0.9729@25°C
Vapor Pres: <1.33hPa (1.00mmHg) @20°C
Vapor Density: Heavier Than Air
Solubility in Water: Insoluble
Evaporation Rate: <1
Flash Point: >254°C / >490°F
Upper Explosion Limit: N/A
Lower Explosion Limit: N/A
Percent Volatile: Not Determined
Molecular Weight: Polymer
=====

Reactivity Data

=====
Stability: Stable
Stability Condition To Avoid: None Known.
Materials To Avoid: Strong oxidizing agents
Hazardous Combustion Products:
Burning Can Produce The Following Combustion Products:
OXIDES OF CARBON, OXIDES OF SILICON, FORMALDEHYDE, CARBON MONOXIDE IS
HIGHLY TOXIC IF INHALED; CARBON DIOXIDE IN SUFFICIENT CONCENTRATIONS CAN
ACT AS AN ASPHYXIANT.
ACUTE OVEREXPOSURE TO THE PRODUCTS OF COMBUSTION MAY RESULT IN
IRRITATION OF THE RESPIRATORY TRACT.
Hazardous Polymerization: Will Not Occur.
Conditions To Avoid Polymerization: None Known.
=====

Toxicological Information

=====
No information relevant to human health hazard evaluation is currently available
=====

Ecological Information

=====
Prevent Runoff
Use Absorbent To Clean Up
=====

MSDS Transport Information

=====
This product is not regulated by the DOT, IMDG, ICAO.
Freight description road: OIL, O/T PETROLEUM, LUBRICATING, NOIBN
=====

Regulatory Information

=====
CERCLA; None
SARA; None
MSL; None
EPA; None
California Prop 65; None
California SCAQMD; VOC=>0.5mmHg@ 104°C / 219.2°F **Not determined**
=====

Other Information

=====
Chemical Inventory
Europe: The ingredients of this mixture are on the EINECS inventory.
United States: The ingredients of this product are listed on the TSCA
inventory or are exempt.
=====

HAZCOM Label

=====
Product ID: POLYDIMETHYLSILOXANE L-45-2000
Supplier: Crompton Corporation
Street: One American Lane
City: Greenwich, CT
Zipcode: 06831-2559, USA
Health Emergency Phone: 800-809-9998;800-424-9300(CHEMTREC)
Label Required: Yes
Health Hazard: 0
Flammability: 1
Reactivity: 0
PPE: X
=====