

# Pipe Section Cleaner

**The Most Effective Method to Clean Pipe**

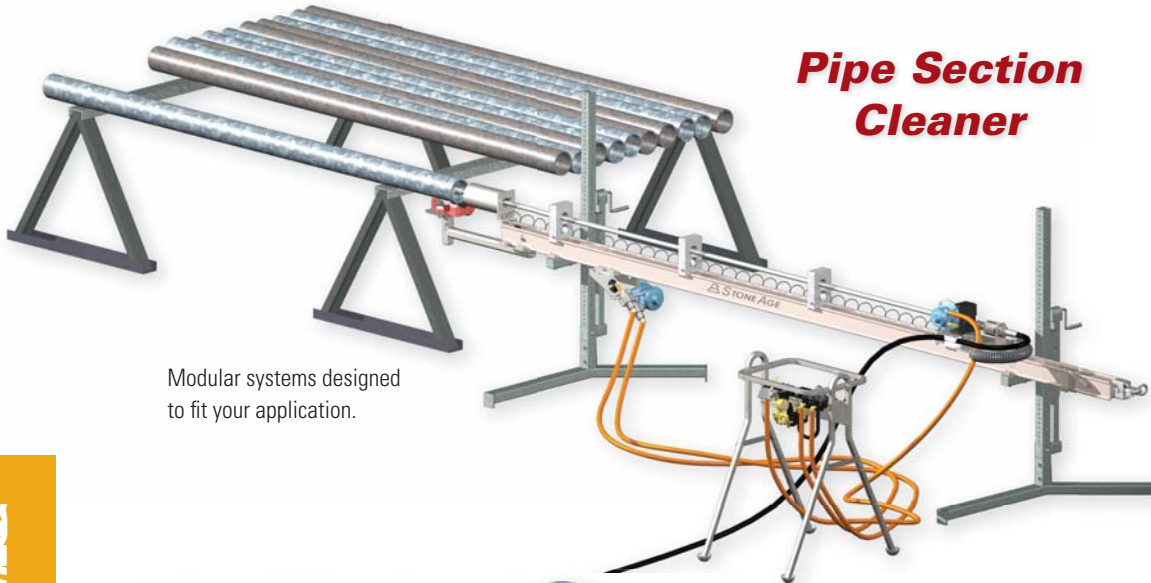

Modular systems designed to fit your application.

## Pipe Section Cleaner

- Remove concrete linings, drill mud, coatings and unplug pipe sections
- Clean scale and NORM from well tubing
- Available in 15k, 20k and 40k psi

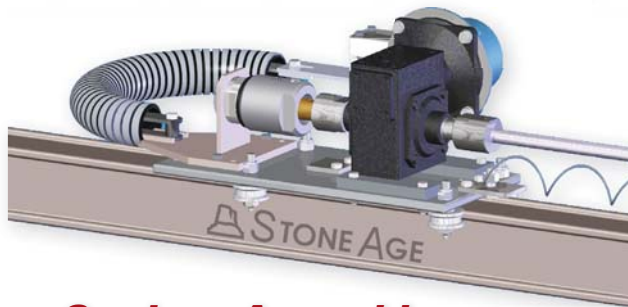

### Carriage Assembly

Heavy duty gearbox adapts to large diameter lances.

When pipe lengths are set on racks and several thousand linear feet require cleaning, the **StoneAge® Pipe Section Cleaner** offers safe and effective results. Every pipe section is consistently cleaned with adjustable rotation and stroke controls. Operators are kept at a safe distance from the high pressure water. The complete package includes the adjustable jack stands, control panel, rigid lance, rail, and tips. The modular design allows any length pipes to be cleaned up to 55 feet and at any pressure up to 40k psi.

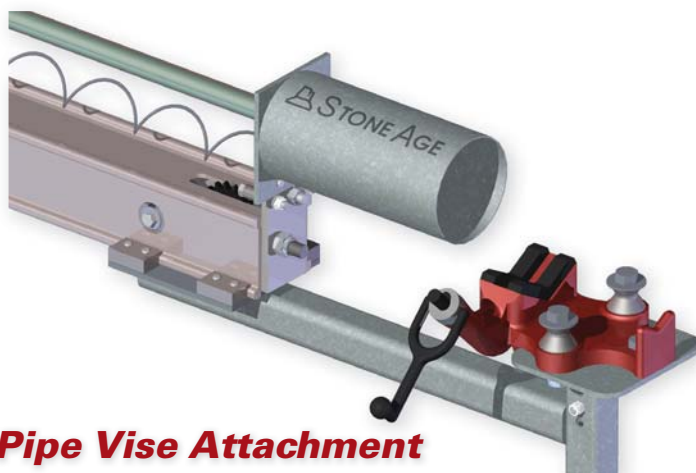

### Pipe Vise Attachment

A rugged pipe vise is included to stabilize pipe movement.

## Specifications

MODEL	Pipe Section Cleaner
Max. Pressure	15k, 20k, 40k psi 1000, 1400, 2800 bar
Flow Capacity	50 gpm 190 lpm
Stroke	Up to 55'
Rail Length	Up to 60'
Weight	350 lbs 160 kg
Rotation Speed	50-300 rpm
Stroke Speed	.50-2.0 ft/sec 150-600 mm/sec

Air Requirement: 80-130 cfm @ 80-100 psi  
2.3-3.6 m<sup>3</sup>/min @ 6-7 bar