



WATERBLAST TOOLS

stoneagetools.com • sewernozzles.com



## High Pressure Fitting Assembly Guidelines and Torque Recommendations

This information is designed to demonstrate the proper preparation and assembly of high pressure fittings and components. Understanding these procedures is critical to the safe operation, maintenance and longevity of your tools and systems.

**CAUTION: IF YOU APPLY THESE TORQUES WITHOUT AN ANTI-SEIZE COMPOUND ON STAINLESS STEEL CONNECTIONS, THEY WILL GALL AND CAN BE RUINED.**

### Always observe these precautions when tightening tools:

The condition of the threads is important to ensure proper engagement for strength, and threads should always be inspected before use.

Proper tightening is important to ensure sealing and to prevent unthreading due to twisting or vibration. However, high pressure waterblast fittings are commonly made with stainless steel, and thread contact force makes them susceptible to galling if not properly prepared with an anti-seize compound before assembly. **StoneAge**® recommends the use of Parker Thread-Mate™ for tapered pipe threads and Blue Goop® for straight threads. High temperature anti-seize compounds containing metallic particles are not recommended as the particles can damage sapphire nozzles.

If wrench flats are provided on the components, use only correctly sized open-end wrenches. Teeth from pipe wrenches can initiate cracks in hard stainless steel components.

## Tapered Pipe Threads

Tapered pipe threads (npt) seal by contact of threads. Use only pipe threaded components that are marked with pressure rating, and do not operate above the maximum pressure rating. A paste type anti-seize compound such as Parker Thread-Mate™ works most effectively with npt threads.

- Use anti-seize compound on male thread, then 2-3 wraps of Teflon® tape (larger than 3/4 npt use 3-4 wraps).
- Prepared fittings should engage about 2 turns by hand and at least 5-6 turns before reaching the recommended torque. Failure to reach minimum engagement usually indicates poorly formed or damaged threads.

### Torque Recommendations for Tapered Pipe Threads:

1/16 npt	3-4 ft-lb	(4-5 N-m)
1/8 npt	15-17 ft-lb	(20-23 N-m)
1/4 npt	18-21 ft-lb	(24-29 N-m)
3/8 npt	20-25 ft-lb	(27-34 N-m)
1/2 npt	40-45 ft-lb	(54-61 N-m)
3/4 npt	65-75 ft-lb	(88-102 N-m)
1 npt	95-120 ft-lb	(129-163 N-m)
1-1/4 npt	130-150 ft-lb	(176-203 N-m)

## Metric Threads

- Straight threads, use Blue Goop® or other anti-seize.
- Seal on O-Ring or washer at flat bottom, on taper with hose ends.
- Should thread all the way together by hand.

### Torque Recommendations for Metric Threads:

M7	18-20 N-m	(13-15 ft-lb)
M24	90-105 N-m	(66-77 ft-lb)
M36	190-220 N-m	(140-162 ft-lb)

Blue Goop® is a registered trademark of Swagelok Corporation.  
Threadmate™ is a trademark of the Parker Hannifin Corp.  
Teflon® is a registered trademark of E. I. Du Pont de Nemours and Company Corporation

## BSPP Threads

- Straight threads, use blue goop or other anti-seize.
- Seal on washer at flat bottom for pressures up to 1000 bar, or bonded washer under shoulder at top for pressures up to 350 bar.
- Should thread all the way together by hand.

### Torque Recommendations for BSPP Threads:

1/8 BSPP	20-22 N-m	(15-16 ft-lb)
1/4 BSPP	30-35 N-m	(22-26 ft-lb)
3/8 BSPP	40-50 N-m	(30-37 ft-lb)
1/2 BSPP	55-65 N-m	(41-50 ft-lb)
3/4 BSPP	90-100 N-m	(66-74 ft-lb)
1 BSPP	135-160 N-m	(100-118 ft-lb)
1-1/4 BSPP	200-230 N-m	(150-170 ft-lb)

## Autoclave Fittings (Cone and Thread)

These fittings use straight threads and seal on a tapered cone. There are two pressure ranges for this type of connection; medium pressure up to 22,000 psi, and high pressure up to 40,000 psi. The traditional design consists of pressure containing tubing with a cone on one end and a left-hand thread for a collar, and a larger gland nut with right-hand threads. Fitting sizes are indicated by tubing O.D.

Anti-vibe, an additional feature typically included, consists of a split tapered collet that grips the tubing in support to prevent cracking at the left-hand thread.

Variations of these fittings are made where the entire geometry is reproduced in one piece, and where the tubing itself is directly threaded into a port with either left or right hand threads.

Female ports have a weep hole that will leak if the fitting is not tightened, if the cone surface is damaged, or if the collar is not threaded on far enough to allow contact of the cone to the seat. If a connection leaks along the tubing through the inside of the gland nut, inspect for a crack in the tubing threads.

### Gland and Collar Assemblies

- Inspect cone surface for damage.
- Use Blue Goop® anti-seize on all male threads.
- Slide gland nut onto tubing, then thread on collar until one thread shows between collar and cone.
- Tighten medium pressure anti-vibe nut last while holding other flats.

## Autoclave Fittings continued

### One Piece Connections

- Inspect cone surface for damage.
- Use Blue Goop® anti-seize on male threads and lightly on cone.

### Torque Recommendations for Autoclave Connections:

1/4 L.H., R.H.	5-6 ft-lb	(6.5-8 N-m)
1/4 MP	18-20 ft-lb	(24-27 N-m)
1/4 HP	22-25 ft-lb	(30-34 N-m)
3/8 L.H., R.H.	16-18 ft-lb	(22-24 N-m)
3/8 MP	28-32 ft-lb	(38-43 N-m)
3/8 HP	35-40 ft-lb	(47-54 N-m)
9/16 L.H., R.H.	34-38 ft-lb	(46-52 N-m)
9/16 MP	50-55 ft-lb	(68-75 N-m)
9/16 HP	65-70 ft-lb	(88-95 N-m)
3/4 MP	75-80 ft-lb	(102-108 N-m)
1 MP	100-110 ft-lb	(135-150 N-m)

### Autoclave Fittings Cross-Sectioned

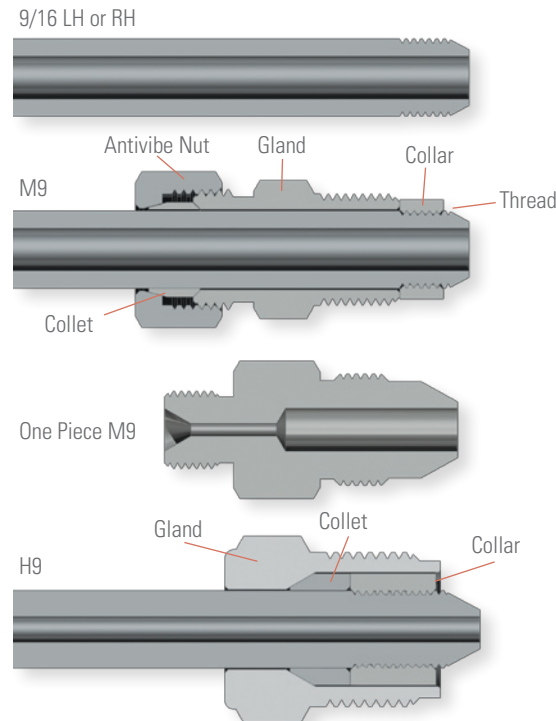

## Female Swivel Hose Ends (Type M)

- These have straight threads, sized by inches. They seal on a cone in the female nut.
- Use Blue Goop® anti-seize on male threads, should thread together by hand.

9/16	34-38 ft-lb	(46-52 N-m)
3/4	55-60 ft-lb	(75-81 N-m)
7/8	75-80 ft-lb	(102-109 N-m)
1	90-100 ft-lb	(122-135 N-m)
1-5/16	130-150 ft-lb	(176-203 N-m)

## Sapphire Nozzles OS4, OS6, OS7

- Use Blue Goop® anti-seize on male threads, small amount on cone.
- Larger sizes require more torque to seal.

1/4-28 OS4	4.5-5.5 ft-lb	(6-7.5 N-m)
3/8-24 OS6	14-16 ft-lb	(19-22 N-m)
7/16-20 OS7	25-27 ft-lb	(34-37 N-m)

## K, G made by StoneAge

- Straight threads, use Blue Goop® on male threads.
- Seal with O-ring in flat bottom port.

K	90-100 ft-lb	(122-135 N-m)
G9	34-38 ft-lb	(46-52 N-m)
G12	55-60 ft-lb	(75-81 N-m)



stoneagetools.com • sewernozzles.com

466 S. Skylane Dr. • Durango CO 81303  
 1-866-795-1586 (Toll Free in the U.S.)  
 970-259-2869 • Fax: 970-259-2868  
 email: sales@stoneagetools.com

Blue Goop® is a registered trademark of Swagelok Corporation.  
 Threadmate™ is a trademark of the Parker Hannifin Corp.  
 Teflon® is a registered trademark of E. I. Du Pont de Nemours and Company Corporation