

- Waterblast Tools
- Up to 40Kpsi
- Parts & Service
- Customer Support

## StoneAge celebrates with a groundbreaking ceremony!



StoneAge is experiencing tremendous growth and we have outgrown our current facility! To prepare for the future we are building a new state of the art facility. The new location will be just 4 miles south of Durango. Our new home will be 33,000 square feet on 4 acres, which is more than twice our current size with room to grow. It will include a large testing area, more capacity for fabrication, dedicated classroom, conference areas, and somewhere to park! Project completion is expected by early 2007. We celebrated with a ground breaking party shown above with all the employees, their families, and our Board of Directors.



## Wear Ring now included on every Badger

Our engineers have come up with a simple design that will extend the life of both the **Badger 15k** and **Badger 20k** psi tools. They have added a heat treated 4130 steel wear ring that we will include with all new **Badger** tools being assembled. The wear ring can also be easily installed to any existing **Badger**. The part number for the wear ring is **BA 030**. Look for these on your next **Badger** purchase and if you would like any wear rings for your existing tools just let us know.





# Asia Waterjet visits Durango

We were recently visited by Steve Ellis and Phil Finlay of Asia Waterjet Equipment. AWE, formerly known as Consultancy Services International, is a distributor for StoneAge in Dubai, United Arab Emirates. They have a long history of representing our products and solving difficult waterblast applications throughout the Middle East region. During their visit we were able to introduce their newest employee, Phil Finlay, to our full range of products and repair courses. You can visit them at [www.hydrojettingonline.com](http://www.hydrojettingonline.com)



STEVE ELLIS, PHIL FINLAY, AND BILL SHIRES

**NEW** *Banshee Nozzles proving to be a huge success!*

STONEAGE BANSHEE

Patent Pending

We introduced the **Banshee** tools one year ago this month at the Waterjet Technology conference in Houston. Since then we have made many more advancements with this technology. The **Banshee** tools deliver the highest quality jets for the most effective cleaning. Customers are calling us and reporting how much faster and more productive their tough tube cleaning applications are getting finished. For all the information regarding the industries best new tube cleaning tools visit the **Banshee** page in the *Tube & Lancing* section at [www.stoneagetools.com](http://www.stoneagetools.com)

## Increasing Seat & Seal life for the 40Kpsi Barracuda

We have some recommendations for increasing the life of your 40Kpsi **Barracuda** high pressure seats and seals. As with any industrial tool, the 40Kpsi **Barracuda** requires routine maintenance in order to achieve and maintain it's maximum performance.

For maximum tool life and optimum performance the end of the BC 001 Shaft needs to be free of any damage. There are two things that can damage the shaft end. The shaft end will get pitted and erode over time through normal use and should be repaired or replaced if carbide seat erosion occurs. The second event that can happen is carbide seat breakage. If a carbide breaks, it damages the shaft end, and the shaft must be repaired or replaced to keep from breaking new carbide seats. The BC 001 Shaft can be refaced by a competent machine shop. If you do not have access to a competent machine shop, then please send it back to StoneAge for proper repair or replacement. You can view a presentation with all the details at our web site [www.stoneagetools.com](http://www.stoneagetools.com)

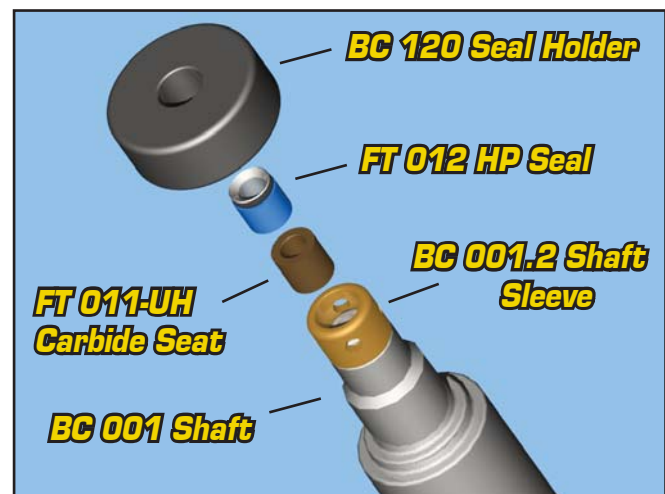

**Barracuda** HIGH PRESSURE SEAL ASSEMBLY

# Specialty Web Section now available

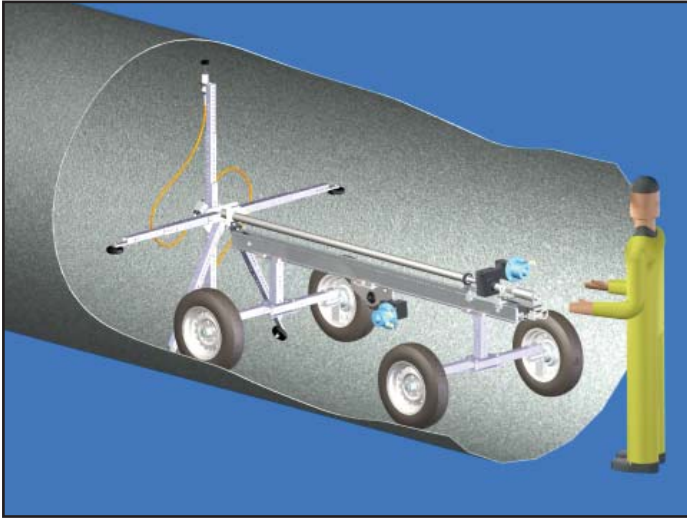

THE TUNNEL CLEANER

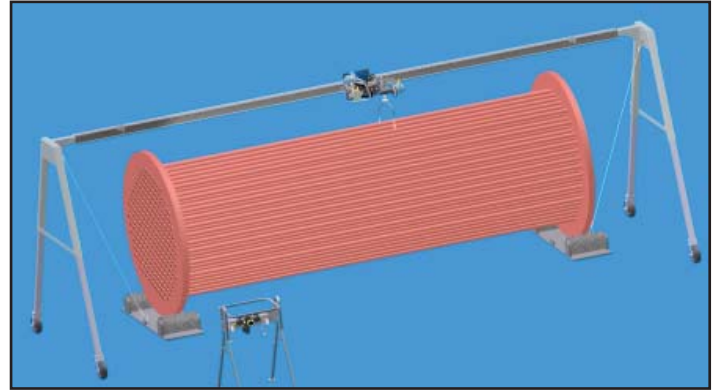

BUNDLE BLASTER

Do you have an unusual waterblast application? Chances are we have already designed a solution. With over 25 years of designing waterblast tools we have developed a wide variety of special purpose solutions. We now have a unique section on our web site highlighting our most successful custom projects. Visit our web site [www.stoneagetools.com](http://www.stoneagetools.com) and go to the *Specialty Products* section. There you can view these custom projects by application type and view animation clips of these tools in action. These products are not in the catalog and are not readily available to ship, so be sure to contact us for pricing and availability. We will be continually adding to this section so be sure to check it often. If you have an application that is not there let us know and we will do our best to help.

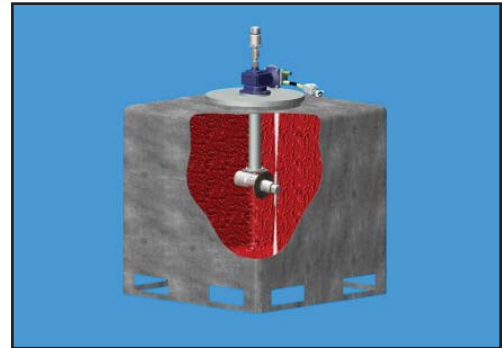

GEARHEAD TOTE CLEANER

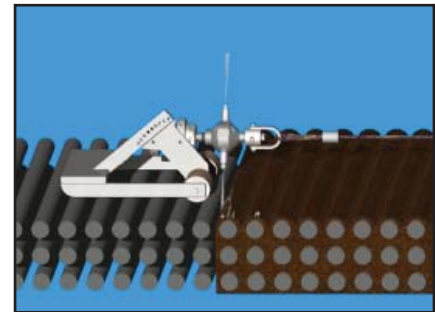

BJ 120 ECONOMIZER CLEANER

## ***RLM Pipe Cleaners add safety and increase production***

The ***RLM Pipe Cleaner*** has proven itself as an effective tool when used for drilling tubulars, removing NORM scale deposits, and other repetitive pipe cleaning tasks. We have recently upgraded the gearbox and added an adjustable pipe vise to the front end. The ***RLM Pipe Cleaner*** is a modular system that is air powered for both lance rotation and for lance advancement. All of the specifications for this unit can be seen on our website under *Custom Lancing Systems*.

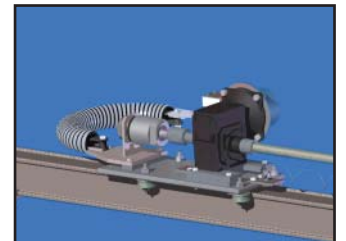

IMPROVED GEARBOX FOR BETTER DURABILITY

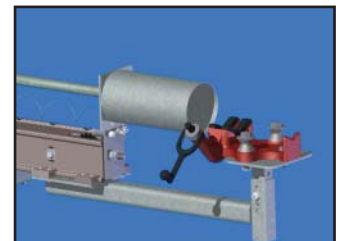

ADJUSTABLE PIPE VISE FOR 2" UP TO 5.5"

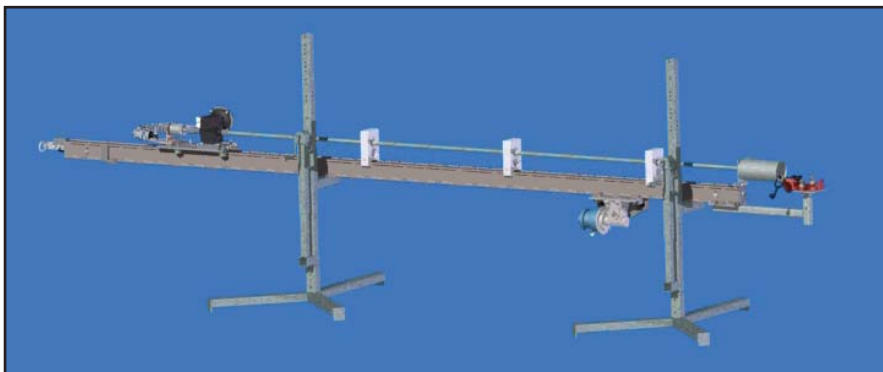

# Recent Product Upgrade

## The SM-Air gets a gearbox upgrade

The **SM-Air** is most commonly used in boilers, tanks, and other confined spaces where the demands on waterblasting equipment are the toughest. Contractors use as much as 300 gpm with 10,000 psi to penetrate the thick deposits. To meet these demands, we now use a more durable Boston Gearbox. These gearboxes are in stock and all future **SM-Air** units will come standard with this upgrade. Pictured at right is our standard **SM-Air** package which includes the swivel, air motor, gearbox, oiler, head, arms, and nozzles.

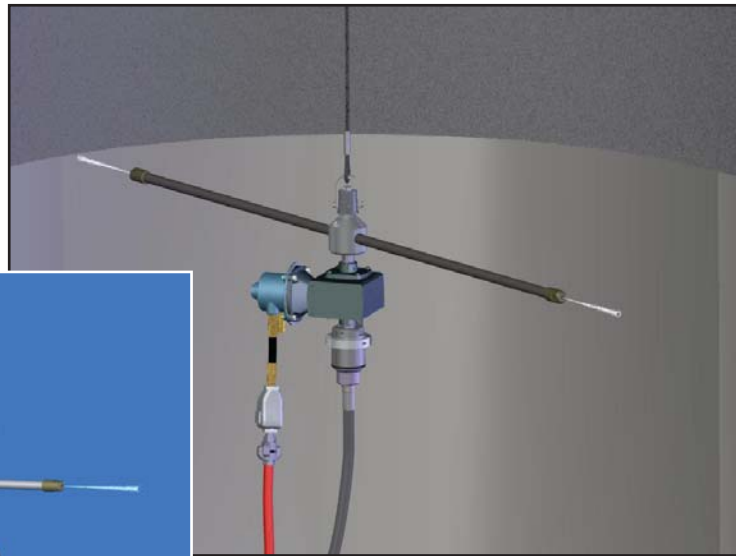
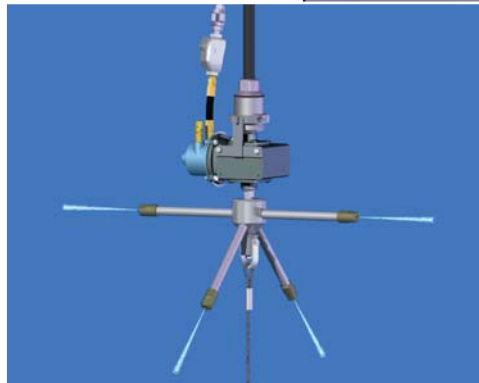

THE **SM-Air** CLEANING A LARGE DIAMETER STACK WITH OPTIONAL EXTENSION ARMS

## Safety Guidelines now included with every shipment

We are now including our **Recommended Safety Guidelines for StoneAge Waterblast Tools** with every package. We encourage you to take a look at these guidelines and get back to us with your comments.

We also suggest you take a look at the Waterjet Technology Association web site for further safety guidelines. Copies of their Recommended Practices are available in Spanish by calling them direct or from StoneAge upon request.

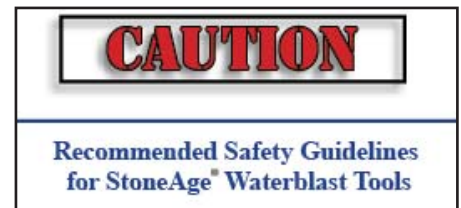

CHANGE SERVICE REQUESTED

Durango, CO 81302

PO Box 2907

**STONEAGE** WATERJET TOOLS

PRRST STD  
US POSTAGE  
PAID  
DURANGO, CO  
PERMIT NO. 477