

NEWSBLAST

March 2003

Hydro-Klean Ingenuity Meets the Challenge

Logan Contractor's Supply of Urbandale, Iowa, purchases concrete curing compound in 5,000 gallon truck-loads and fills 275 gallon totes for their customers. You might have seen the dried white material at highway construction sites. To make sure quality is up to par, they approached Hydro-Klean (Des Moines, IA) to figure out how to clean each tote before refilling. Removal of dried material on the inside of the tote's upper surface presented a serious challenge. The totes are molded plastic, about 4 ft cube in an aluminum cage, with a fill opening 4" off the top center.

Armed with a dirty tote and confidence in their waterjetting expertise, Hydro-Klean personnel experimented with various techniques to determine how best to approach the job. Hydro-Klean uses a variety of StoneAge tools, and selected the RJV-2D Nozzle because of its compact size, dependability, and jetting options. Using one jet at 45°, one at 135°, and two at 90°; they demonstrated thorough cleaning of the vertical walls, as well as the difficult top and bottom surfaces. The RJV is hand held on a rigid lance and stroked, from the top entry port to the bottom of the tote. The technique is well established, and used in tote cleaning stations from the US to Australia, where farm produce totes are cleaned this way. Even so, the story doesn't end with tool selection.

Although the curing compound and rinsate from the cleaning process were non-hazardous wastes, they were not suitable for discharge into a storm sewer or the ground surface. So Hydro-Klean had to solve the problem of containing, collecting, and transporting the rinsate to a permitted disposal facility. Building a permanent pit or containment structure at the Logan facility would have been expensive and time-consuming, clearly not in the customer's best interest. And their facility lacked a good space to build the collection system anyhow, so it was back to the drawing board for Hydro-Klean. HK personnel designed and built an above ground containment structure in which to wash totes. The structure evolved from a modified polyethylene tank and a pickup truck load of treated lumber. The result is a mobile, tote-washing station that allows HK personnel to travel to the customer's site, wash between fifty and sixty totes per day and collect all the rinsate material from the cleaning process. The rinsate is then removed and transported to the disposal facility via one of HK's powerful vacuum trucks.

Four Jets Clean All Surfaces

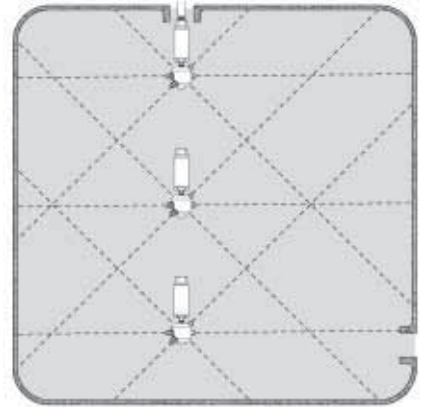

Jeff Logan, Operations Manager for Logan Contractor's Supply commented, "Hydro-Klean has been excellent to work with! We had to overcome a few procedural modifications and through it all HK proved their willingness to help and see that the job got done." Experience, knowledge, and ingenuity are what makes good industrial service contractors like Hydro-Klean valuable to their customers. Thanks to Brian Rinehart of Hydro-Klean for submitting this story.

Fittings, Couplings, & Adaptors

In the new 2003 Catalog all the adaptors, couplings, and fittings stocked by StoneAge appear with photos. There are 99 different part numbers listed. We do not have adaptors for BSP or metric threads, but suggest that you contact our distributors in Europe, who routinely adapt StoneAge equipment for many of their customers.



Thank You For Visiting Us In Nashville!



We appreciate seeing customers and hearing stories about what they have done with their StoneAge tools. If you have not attended the late February Pumper/Cleaner Environmental Expo, plan to do so next year!



WATERJET TOOLS

970-259-2869 Phone 970-259-2868 FAX
<http://www.stoneagetools.com>



Blue Twister Sells Vector Jet-Vac Truck

Municipal sewer departments know where their problem drains are. So when Boyle Equipment demonstrated the Vector 2100 Series jet-vac machine to the city of Trinidad, Colorado; they faced an uphill line clogged with roots. Boyle's Lance Petty knew he had better try the best root-cutting nozzle he had, the Vector **Blue Twister** (made by StoneAge). The result? One combination truck sold, but only if it came equipped with the **Blue Twister**.

StoneAge controlled rotation technology has been used since 1986 in waterblast nozzles, and since 1996 in **Warthog Sewer Nozzles**. Even after all these years, no competing sewer nozzle has matched the **Warthog's** effective rotation control and resulting power. It is still unmatched in root-cutting and grease-unplugging performance.

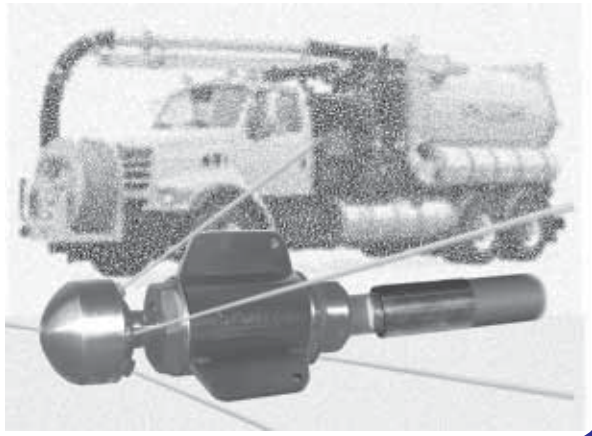

New 40 Kpsi Waterjet Tools

See the 2003 StoneAge Catalog for new 40 Kpsi waterjet tools. Use less water, lose less power to pressure drop, cut hard deposits and coatings with these durable tools. Dependable, proven StoneAge technology is now available for jobs that demand ultra high pressure.

2003
Catalog

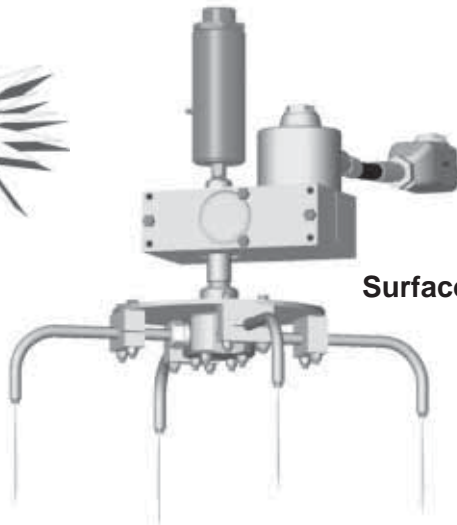

UH-40
Air Rotated
Surface Cleaning Systems

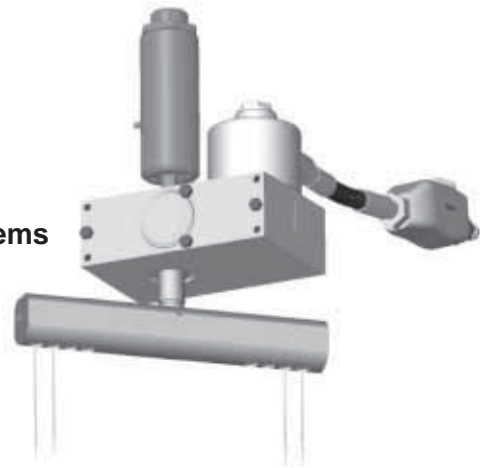

Barracuda
Self-Rotating Gun Nozzle
Model BC-UH

STONEAGE®

WATERJET TOOLS
970-259-2869 Phone 970-259-2868 FAX
<http://www.stoneagetools.com>



What Else Is New?



Badger 2D
Self Rotated
Handles 4" Elbows



WKRC
Trailer Jetter Kit
Sewer Tools You Need

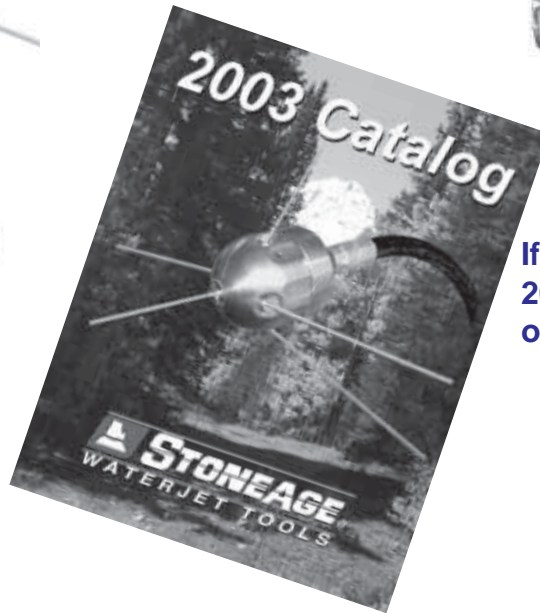

If you do not yet have the 2003 Catalog, order one at our website "Info Center"



BFW
Big Flow Waterblaster
Versatile Artillery Piece for Serious
Waterblast Campaigns

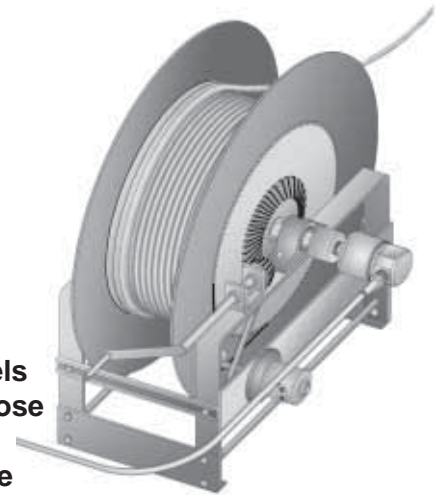

WHB
Waterblast Hose Reels
Handle Continuous Hose
Lengths To 550 ft.
0.4 to 1.6 in. ID Hose

New Gearboxes for More-Compact Air Rotated Systems

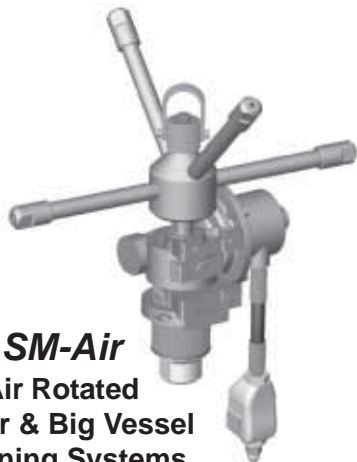

SM-Air
Air Rotated
Boiler & Big Vessel
Cleaning Systems

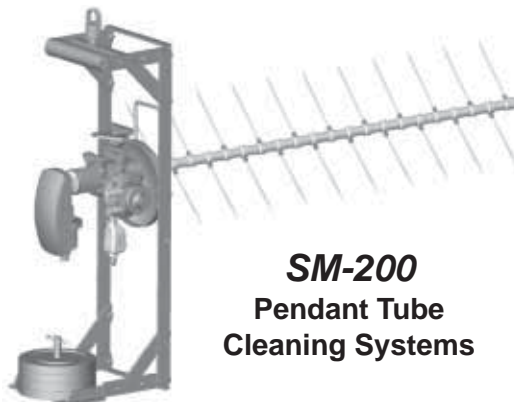

SM-200
Pendant Tube
Cleaning Systems



SG-60 & 70
Air Rotated
Cleaning Systems

© 02/03



WATERJET TOOLS

970-259-2869 Phone 970-259-2868 FAX
<http://www.stoneagetools.com>



ADDRESS SERVICE REQUESTED

Warthog Used in Forest Fire Aftermath

Last summer, the Missionary Ridge Fire consumed 70,400 acres of the San Juan National Forest, just North-east of Durango. Thanks to Tom Harris at the USDA Forest Service and Dan Bender of the



LaPlata County Sheriff's Office for the photos at the right. At the fire's peak, 1,932 firefighters were at work. It started June 9, and was not 100% contained until July 17. 56 Homes were destroyed. Then late summer rains brought mudslides and rock slides that continue to threaten property. LaPlata County roadworkers have since become experts at plowing debris off local roads. Mud and rocks flowing from the burnt areas cover roads, and fill culverts whenever we get a heavy rain. In this case, the county put their Vactor combination truck to work with StoneAge's **Warthog WG-1** sewer nozzle to clean mud and rocks out of a culvert draining the highway into the Florida River. These powerful nozzles have handled sand-filled drains on the Caribbean island of Nevis after a hurricane, ice at Colorado ski resorts, mine tailings in Chile,

and a host of other difficult drain cleaning situations.

Get the article "4 Keys" off our website, for the technical details that explain why the **Warthog** is the most powerful drain cleaning nozzle you can buy. In a few words, the secret is excellent jets, just a few powerful ones, rotated at controlled speeds. Others have tried to imitate the **Warthog's** powerful features. But the **Warthog** remains the only sewer nozzle available with truly effective rotation speed control.

So get the original, the best, the **Warthog**. Models are available from 4 gpm to 80 gpm jetters. Each one is custom jetted for the customers pump and hose.



WATERJET TOOLS

970-259-2869 Phone 970-259-2868 FAX

<http://www.stoneagetools.com> © 02/03

