

NEWSBLAST

December 1999

Warthog Sewer Cleaning - Feedback from the Southwest



Hired to clean a grease-fouled sewer at a fast food operation, Bio Remedies of El Paso, Texas put the **Warthog** to work! The line was almost completely plugged before cleaning operations started. With 17 gpm at 4 Kpsi, the **Warthog's** powerful rotating jets cut the grease in short order. The secret behind this tool's power is simple - use the fewest of the most powerful jets possible, and rotate at a controlled speed. The **Warthog's** unique viscous fluid governor keeps rotation speed within the tool's most powerful range. It works in sewers, culverts, and process drains. It's far more powerful than competing tools with many jets that divide the power into too many small frac-

tions, or too fast a rotation speed that deteriorates jet quality. **Warthog** nozzles are used for root cutting, scale, grease, debris, and silt removal. **Warthogs** use an inexpensive, no-leak plastic seal that is easy to replace when it wears out. Each tool is jetted for optimum performance with the customer's pump.



StoneAge at Nashville!

We will exhibit at the Pumper/Cleaner Environmental Expo in Nashville, Tennessee, February 17-20, 2000. It's fun to see customers and hear stories of waterblasting with StoneAge tools. So plan to see us there.

www.stoneagetools.com

Since the new website was started up in August, there have been three important changes. First, our price list is on-line, just click on "Price" on the left-hand menu, any page. Second, the datasheets have been updated consistent with the 2000 Catalog. Finally, links to other waterblast equipment manufacturers was added to help our customers find all the things they need. Let us know if you want your website to be linked.

Mailing & E-Mailing Lists

Let us know if you wish to be added to, or dropped from our mailing list. Also we want to build as complete a directory of e-mail addresses as we can. So e-mail us yours!

Tool Maintenance - Help!

While StoneAge tools are as simple as we can make them, we realize that maintenance can be less simple in the field, especially if it's the first time you have ever taken one apart. We offer the following help:

- Operator's Manual - Every tool is shipped with a manual with parts lists, assembly diagrams, and detailed maintenance instructions. If yours is lost, call us for a free replacement.
- Website - Complete datasheets help you identify what model tool you have, and maintenance kits available for it.
- Serial Number Database - StoneAge keeps a database with information on every tool sold. We can often look up your tool to determine jetting, model, and maintenance history.
- Phone Assistance - Call us to discuss your problem with an engineer or one of the technicians who repair tools in our shop.
- Repair Services - Send us your tool with as much information as possible about the problem. Turnaround time is usually only a day or two.

© 12/99

 **STONEAGE**®

WATERJET TOOLS

970-259-2869 Phone 970-259-2868 FAX

Sttp://www.stoneagetools.com



CST Cable Swivel Tool

New for Furnace Cleaning

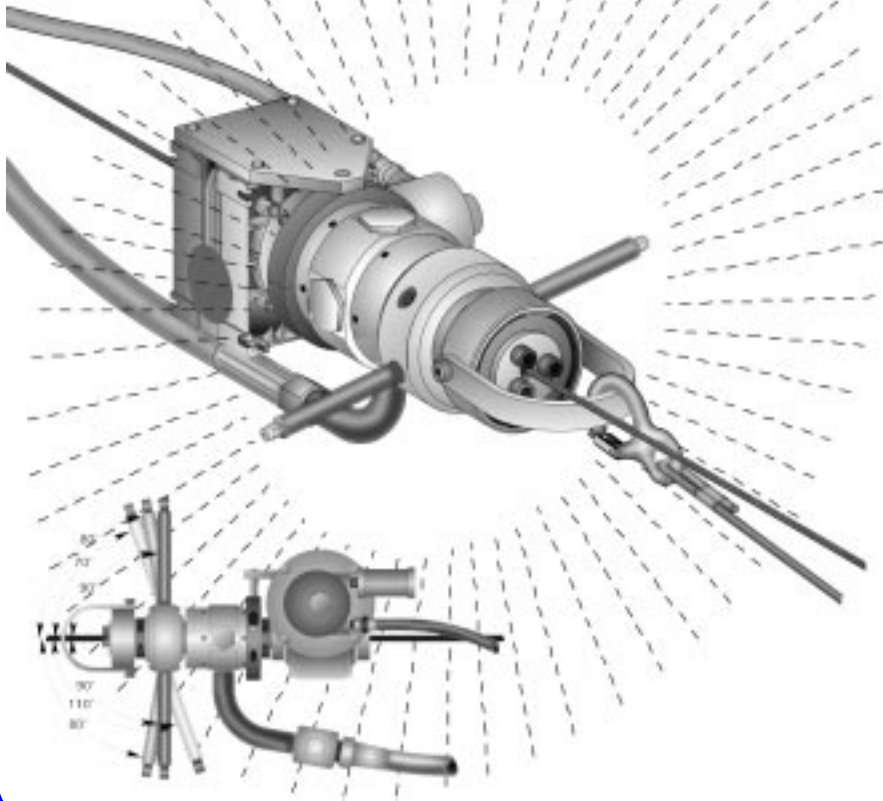

Furnace cleaning is tough! Access is poor, making fly ash and other deposits difficult to remove. Downtime is expensive. Manual methods involve vessel entry precautions, setup and takedown time. Each man in the vessel is limited to the jet power he can safely handle. Mechanized tools are preferred; but have always been difficult to install, and to position for effective jetting of the deposits. The new **CST** avoids most of these problems! It is StoneAge's latest offering for more effective waterblasting with less exposure of people to the hazards of the job.

The **CST** is an air-powered swivel, with hollow shaft, allowing it to slide on a cable stretched between two anchors. It handles up to 150 gpm at 10 Kpsi. The versatile 6-port head allows several jetting options, including the ability to pull itself along the cable. Extension nipples assure excellent jet quality for hard-hitting power at relatively long standoff distances.

Measure its value in terms of manpower reduction, safety improvement, or quicker turnaround. The conclusion is the same. The **CST** is a money-maker!



BJ 097 X-Style Centralizer

Available in three size ranges - up to 12 ft diameter, the BJ 097 with a **BJV** Self-Rotating Nozzle, is the answer for stacks, columns, and other vertical applications. It requires only one bolt to secure in its un-folded position.

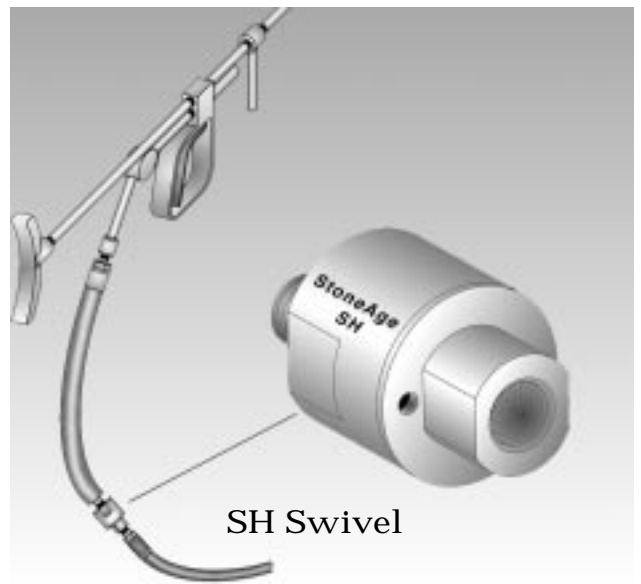

SH Swivel

Hand-held "shotgun" operations are demanding enough without having to fight the hose! The **SH** Swivel solves hose handling. It only weighs 1 lb 14 oz. with 1/2" npt inlet and outlet ports. It handles up to 60 gpm at 15 Kpsi with only 13 in-lb of torque. It is a good choice for hose reels, and hose-to-hose connections as well.

© 12/99

STONEAGE®

WATERJET TOOLS

970-259-2869 Phone 970-259-2868 FAX
<http://www.stoneagetools.com>



Warthog Family is Growing!



Warthog users have asked for a tool to go through 3 inch clean-outs, and negotiate elbows in 4 inch sewers. We're pleased to announce its debut. The new **WS** comes with a 2 foot length of flexible hose that makes it possible to go through bends. Inlet connection is 1/2 inch npt. It is rated at 4 Kpsi, and can be jetted for 10 to 18 gpm pumps.

With viscous fluid governor, no-leak seal, and powerful jets, the new **WS** brings legendary **Warthog** power to smaller lines!

Customers who claim that the **Warthog** is the only tool needed on their trucks now have a new option - one that allows them to expand their already outstanding service.

**Warthog-WS
Small**



**Warthog-WH
Medium**



**Warthog-WG
Large**



Warthog Model	Inlet Port npt`	Pump Flow gpm	Pressure Rating Kpsi	Diameter Maximum inch
WS	1/2"	10 - 18	4	1-7/8
WH	1/2"	12 - 20	8	3-1/8
WH	3/4"	20 - 40	8	3-1/8
WG	1"	45 - 80	3	4-1/4

As with all **Warthog Sewer Nozzles**, the **WS** is jetted specifically for each customer's pump. To get the most power possible, the buyer must specify pump flow capacity, operating pressure, hose ID and length. The **WS** is sold complete with jets, and a Service Kit that supports a year's worth of routine maintenance for the average user.

You can see this new tool at Nashville, StoneAge Booth # S-44!

RJV Self-Rotating Nozzle - Better Than Ever!



- **NEW RJ 043-P2 Head** is only 2 in. OD, making the nozzle fit into smaller lines. It is available with pulling ring provision, or with a forward 15° port for unplugging.
- **RJ 075 Centralizer** is just right for 3 in. to 6 in. diameter lines. This one-piece plastic centralizer clamps onto the tool body. Two sizes are available, 3 in. and 4.5 in. diameter. The 3 in. diameter size is standard, and is stocked for quick shipment.

© 12/99



WATERJET TOOLS
970-259-2869 Phone 970-259-2868 FAX
<http://www.stoneagetools.COM>



StoneAge, Inc.
P.O. Box 2907
Durango, CO 81301
ADDRESS CORRECTION REQUESTED

PRSR
U.S. POSTAGE
PAID
DURANGO, CO
PERMIT NO. 477

Barracuda Rotary Shotgun Nozzle End-of-Millennium Sale

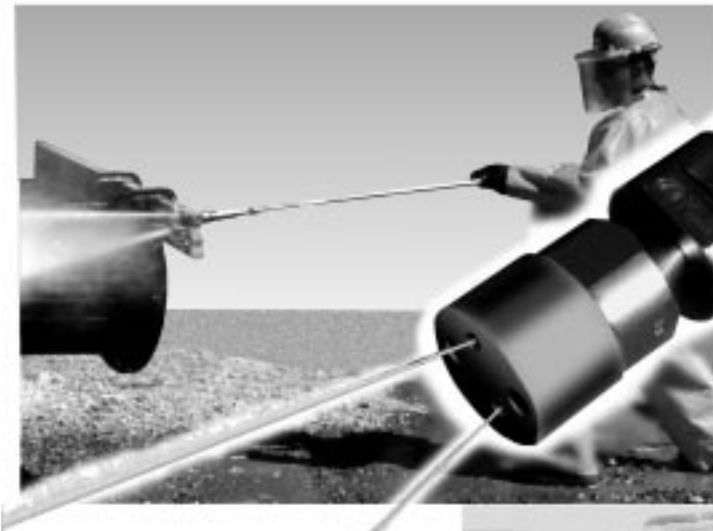

\$ 999

Sale Price

**Expires January 1, 2000
\$ 1150 Regular Price**

**Powerful Jets
No-Leak Seal
5,000 to 20,000 psi
Lightweight
Easy Maintenance
1/4 npt Carbide Nozzles**



The Barracuda Rotary Shotgun Nozzle is based on a simple concept, the power put into the nozzle goes out with the jets - all of it! Nothing is lost to turbulence caused by excessive rotation rate. Proven high pressure seal technology makes it powerful and dependable. The Barracuda is lightweight, with easy field maintenance, and inexpensive parts. It's a proven, practical tool that you can keep on-the-job. StoneAge's 20 years experience with waterjets gives you a design that produces powerful, effective jetting action.

© 12/99

STONEAGE®

WATERJET TOOLS

970-259-2869 Phone 970-259-2868 FAX
<http://www.stoneagetools.com>

