

NEWSBLAST

February 1999

"All Day I Face The Barren Waste..."



without a trace of water, cool water." It's an old western song that might have been right for a tube lancing job at a treatment plant in the Sultanate of Oman. StoneAge distributor Powerflow Rentals - Dubai was contacted for help to clean a slurry brine concentrator. 1490 vertical 2 inch diameter tubes, 50 ft long, were plugged with calcium sulfate. The location is 300 miles inland from Muscat, in a dry, dusty gravel desert where daytime temperatures reached 136° F during the job.

After trying several unsuccessful techniques, the operator erected scaffolding to support a StoneAge rigid, 55 ft. long **Rotary Lancing System**. With the WOMA 30 Kpsi pump, excellent cleaning results were achieved. An average of 100 tubes/day were un-plugged and cleaned.

Two important lessons were demonstrated. Firstly, uniform removal of scale and deposits from tube walls is the key to restoring heat transfer to "new" condition. Mechanized lancing produces much more uniform cleaning than any manual method. Secondly, it's important to depend on reliable suppliers who are willing to make the equipment work for the customer in even the harshest conditions. Thanks go to Mike Biddle at Powerflow Rentals for the story and photos.



StoneAge
20 Years
1999



Thanks to our many friends in the waterblasting business, whose direction and support has resulted in 20 great years.

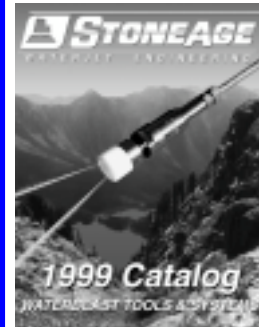

1999 Catalog
The new 1999 StoneAge Catalog is available. If you have not yet received a copy, call us for one. It features a number of new tools, and has expanded to 52 pages.

1999 Trade Show Plans

StoneAge will exhibit at three shows this year. It's a great opportunity for us to meet users of our tools, and learn more about your equipment needs.

- **February 25-27 - Nashville, Tennessee**
Pumper & Cleaner Environmental Expo
- **May 25-28 - New Orleans, Louisiana**
National Petroleum Refiners Association Maintenance Conference
- **August 14-17 - Houston, Texas**
Waterjet Technology Association
10th American Waterjet Conference

Welcome to Visitors - Whether it's to check out new equipment, to better understand how to maintain StoneAge tools, or to meet us and see our factory; we like to have customers visit us in Durango.



Arco den Hollander and Salomon de Snaijer (Salotech - The Netherlands) discuss **Barracuda** maintenance with StoneAge's Doug Wright.



Steindor Gunnlaugsson and Gunnar Hognason (Dyjandi - Iceland) check the **Warthog Sewer Nozzle's** cutting power.



Bengt Grinddal (Aquascand - Sweden) discusses **Ferret Tube Nozzle** maintenance with StoneAge's Doug Wright.



John Tholen, Mike Lake, Tom Zollinger (National Surface Cleaning - Minnesota) check out their new 8-lance **Lancing System** with air-powered **BRUD Positioner**.



WATERJET ENGINEERING

970-259-2869 Phone 970-259-2868 FAX

e-Mail: stoneage@frontier.net

Avoid The Hazards of Vessel Entry



Working in an enclosed space is difficult, and dangerous at best. Any history of industrial accidents includes cases of suffocation, chemical exposure, explosion, and the difficulty of rescuing injured workers. That's why OSHA regulations and company safety rules address "confined space work requirements" in such great detail. So it's no wonder why waterblast contractors try to avoid putting workers into vessels whenever possible.

The Hurricane 3D Nozzle has been a very successful vessel cleaner since its introduction three years ago. Our new 1999 Catalog introduces two new Simple Boom models to make it even more versatile.

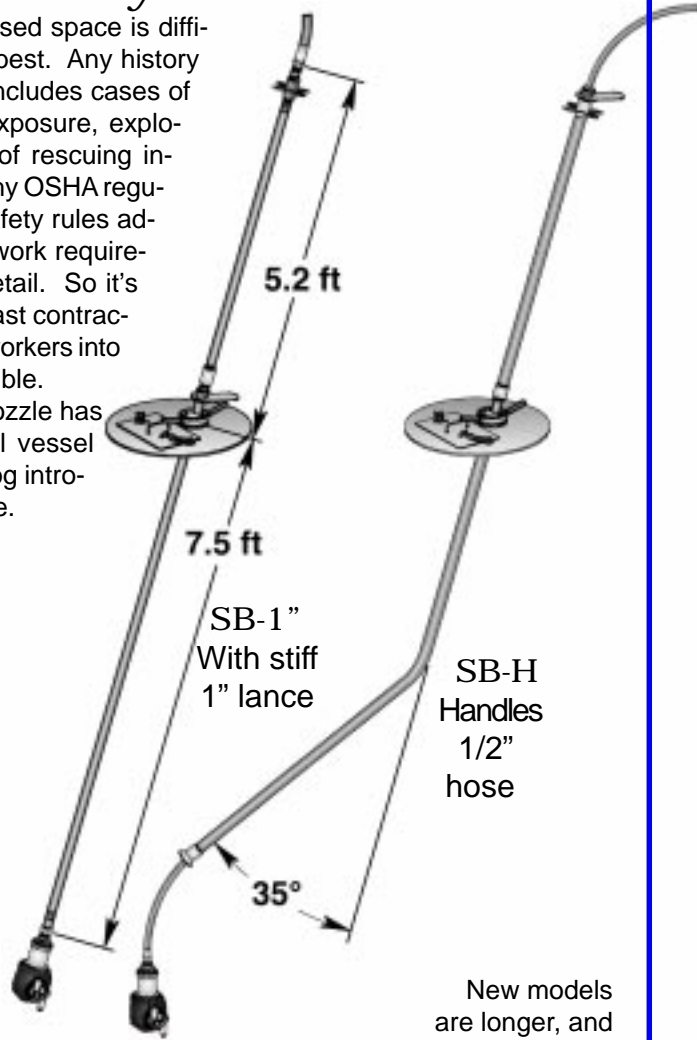

New models are longer, and stiffer than the original. They are also extendable.

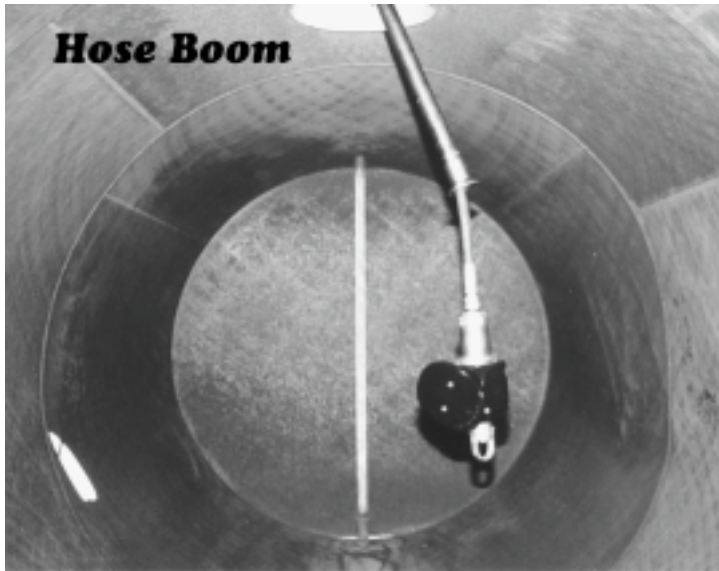

**BJ 320
Backout
Preventer**



**BJ 340
No-Flange Kit**

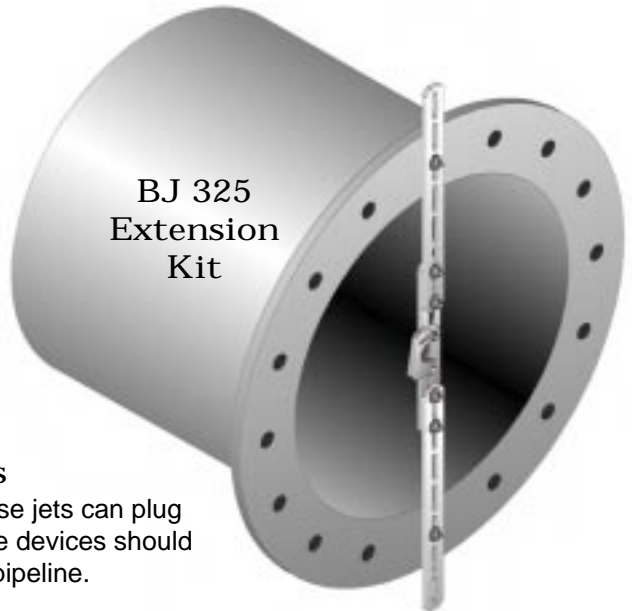

New Line Mole Backout Preventers

You can't always predict what a line mole might do. That's because jets can plug unexpectedly, or fittings can break. This can be dangerous. These devices should help prevent injury caused by line moles coming out of a pipeline.



WATERJET ENGINEERING

970-259-2869 Phone 970-259-2868 FAX

e-Mail: stoneage@frontier.net

**More New Tools
in 1999 Catalog**

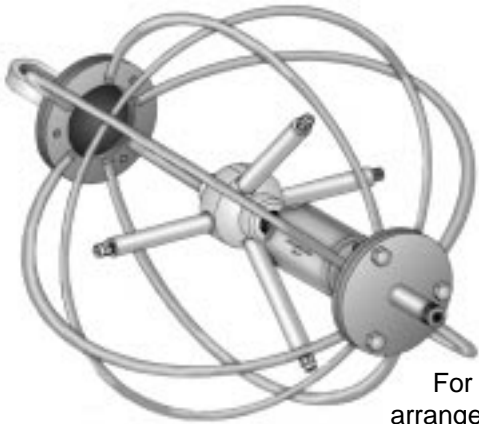

**BJ 100 Ball
Centralizer**

For complex piping
arrangements where built-
up debris might stop
rotation of arms



SG-30 Free Spinner
Self-rotating assembly, the
simplest approach to surface
cleaning applications



SG-GBA

Air-powered rotating
assembly. With heavy-
duty worm gearing



**Barracuda
Shotgun Nozzle**
New technology in rotation
speed control

One Tool - 5,000 to 20,000 psi



**Ferret
Tube Nozzle**

Only 0.91 inch OD
with viscous fluid
rotation speed
control



**BJ 077
Disc Skid
Centralizer**

For cleaning the
bottom of horizontal
tanks, ducts, pits



**BJ 044-P4-7
7 Port Head**

Adds 15° forward jet
for unplugging with
the BJV

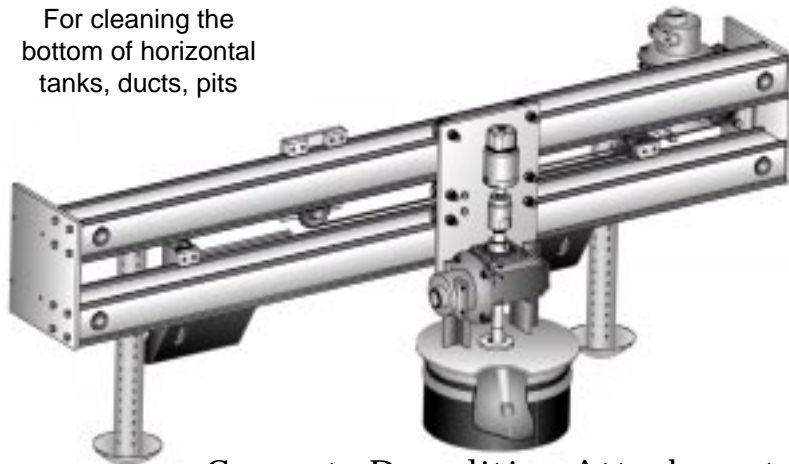

Concrete Demolition Attachment
Attaches to skid steer vehicles for concrete demolition

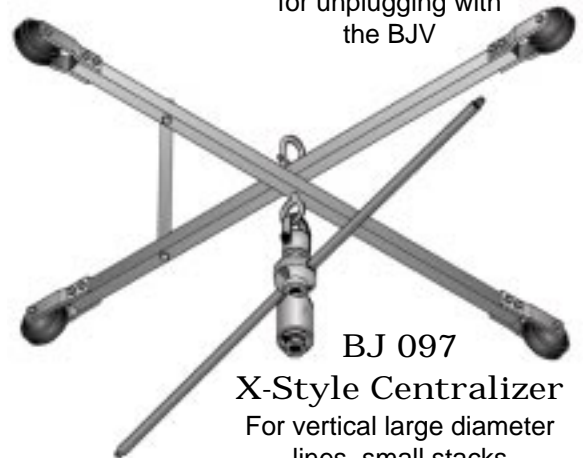

**BJ 097
X-Style Centralizer**
For vertical large diameter
lines, small stacks



WATERJET ENGINEERING
970-259-2869 Phone 970-259-2868 FAX
e-Mail: stoneAge@frontier.net

A Tale of Quality Improvement - New BRUD Positioner



When a customer buys a **Lancing System**, he needs an X-Y positioner to align the lances with the heat exchanger tubes. The new **BRUD X-Y Positioner** makes tube lancing more productive due to several valuable improvements:

- **Weight Reduction** - 35%, from 390 lb to 252 lb for the manual model. Important for efficient setup at the jobsite and shipping cost reduction.
- **Corrosion Resistance** - Increased use of aluminum and zinc-plated steel means longer service life and less maintenance. Zinc plating has replaced painted steel in most StoneAge tools, because of dramatically improved corrosion resistance.
- **Field Conversion to Air Power** - Frequently, the decision of manual cranks versus air motor-powered positioning is made on a cost basis only; before the customer has any experience with the system. Both the BRUD and CB-2D Control Box can now be field-converted to air power with simple kits. It's a great feature for customers seeking maximum lancing productivity.

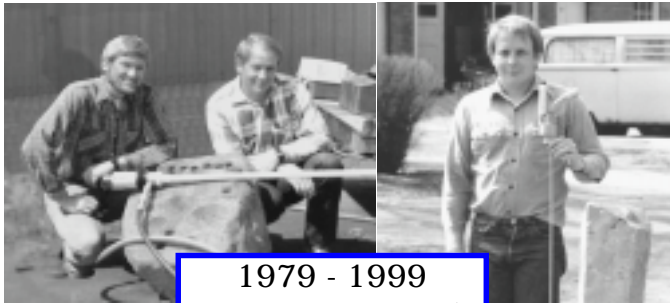

1979 - 1999
20 Great Years!



Introducing New Employees



Clockwise - Carolyn Klinnert - Administration Assistant,
Daryll Fry - Shipping & Receiving, Walter Axthelm - Design



WATERJET ENGINEERING

970-259-2869 Phone 970-259-2868 FAX
e-Mail: stoneage@frontier.net

StoneAge, Inc.
P.O. Box 2907
Durango, CO 81301
ADDRESS CORRECTION REQUESTED

PRSR
U.S. POSTAGE
PAID
DURANGO, CO
PERMIT NO. 586