

**2009 WJTA American Waterjet Conference
August 18-20, 2009 • Houston, Texas**

Paper

OPTIMIZING FLOW AND PRESSURE IN WATERBLAST CLEANING

D. Wright, T. Mathis
StoneAge, Inc.
Durango, Colorado, U.S.A.

ABSTRACT

To increase the rate of material removal in waterblast cleaning, the power applied through the water must be increased. This can be done by increasing the pressure, the flow, or both. It is commonly known that the most effective cleaning pressure occurs at three to five times the threshold pressure, and as a rule of thumb the flow rate is increased at this point. The purpose of this research is to determine the efficiency of material removal through increasing flow rate by increasing the orifice size compared to increasing pressure in several materials with widely varying jetting properties.

1. INTRODUCTION

While it is known that increasing power applied through water will increase the material removal rate, the purpose of these tests was to determine whether increasing pressure or increasing flow was the most efficient means. There are many different material types that will respond differently, but this testing was intended to provide some guidelines for what might be expected.

2. TEST METHOD

Blocks of concrete and rubber were placed under a rotating and traversing single waterjet nozzle as shown in Figure 1, with a feed rate of .46 m/min (1.5 ft/min) and a rotation speed of 400 rpm; all tests were conducted at a constant standoff distance of 76 mm (3 in.), with pressures from 52 to 276 MPa (7,500 to 40,000 psi) and flows from 3.8 to 129 l/min (1 to 34 gpm), producing powers from 19 to 149 kW (25 to 200 hp). The jet path diameter was 152 mm (6 in.) and the test samples were masked by steel to expose a test surface of 76 x 76 mm (3 x 3 in.) The samples were measured for depth of cut and volume removed.

3. RESULTS

3.1 Effect of Pressure

The results for the concrete samples were averaged for all the powers to determine the effect of increasing pressure on this material; this curve is shown in Figure 2. As is typical of all materials, the efficiency improves with increasing pressure up to a maximum, after which an increase pressure results in decreasing efficiency. Figure 3 shows this curve for the rubber samples with the same type of result relative to pressure, with the optimum efficiency occurring around 207 MPa (30,000 psi).

3.2 Effect of Flow

Figure 4 shows the results for increasing power at each pressure tested in the concrete, which is an expression of the effect of flow rate. In this family of curves, it can be seen that the effect of pressure plays a very strong part in efficiency. At the lower pressures, efficiency rapidly got worse with increasing power, while at the higher pressures the efficiency stayed nearly constant. The variation in efficiency was mostly constant other than at the lowest pressure, with an average difference of 30% between the pressures. In this material, efficiency did not improve at any point with increasing power. The overall average of efficiency for increasing power is shown in Figure 5, with a variation in range of 49%.

Figure 6 shows the results for increasing power in the rubber at each pressure. At the lowest pressure tested, the efficiency rapidly improved with increasing flow rate, which was the complete opposite of the response in the concrete. While not as pronounced, this trend continues with increasing pressures. The variation in efficiency was mostly constant but with much less difference between the pressures than in the concrete, averaging 15%. The overall average of

efficiency for increasing power in rubber is shown in Figure 7; efficiency initially improves with increasing power, it then flattens before slightly deteriorating; it varied over a range of 30%.

Figures 8 and 9 illustrate the effect of increasing power for the two materials at each pressure tested. The slopes of the curves for increasing power were overlain on the average effect of pressure curves to provide a feel for the relative effect of increasing flow compared to increasing pressure.

4. CONCLUSIONS

The purpose of these tests was to determine the effect of increasing power through increasing pressure compared to increasing flow, in two materials with widely varying properties. While the effect of increasing pressure for both of these materials was nearly identical, the effect of increasing flow was nearly opposite. It was determined for both materials that increasing power through increasing flow when operating at the optimum pressure will result in nearly constant efficiency, and improvements in efficiency can be expected in softer materials through increasing flow rate as well as increasing pressure.

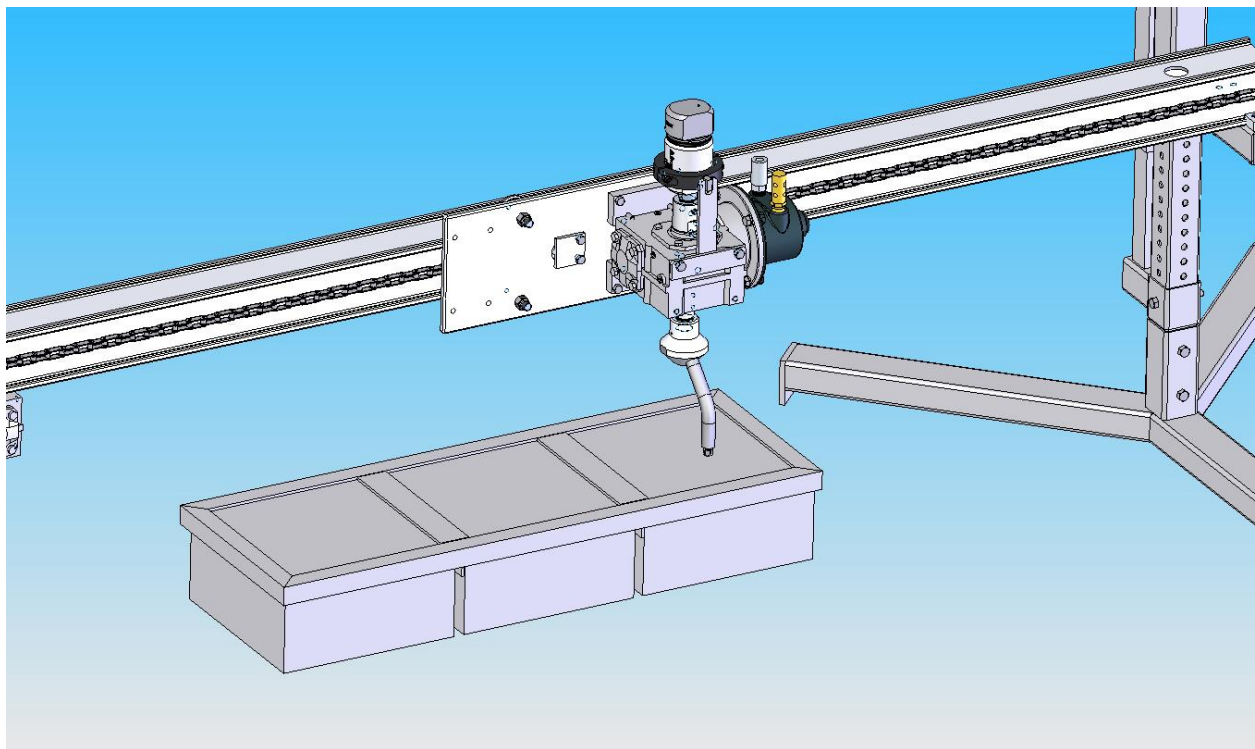

**Arrangement Used for Testing
Figure 1.**

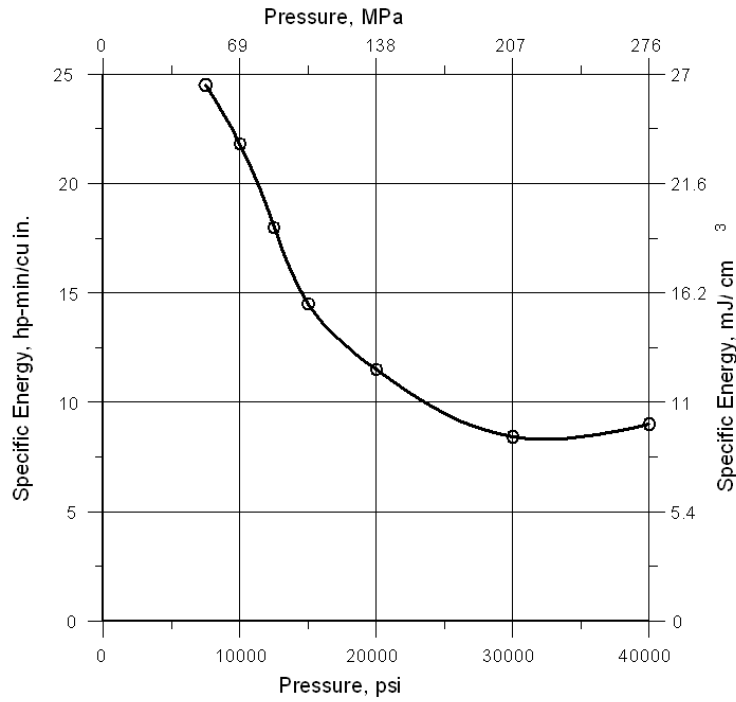

**Relationship of Pressure and Efficiency in Concrete Test Samples
Figure 2.**

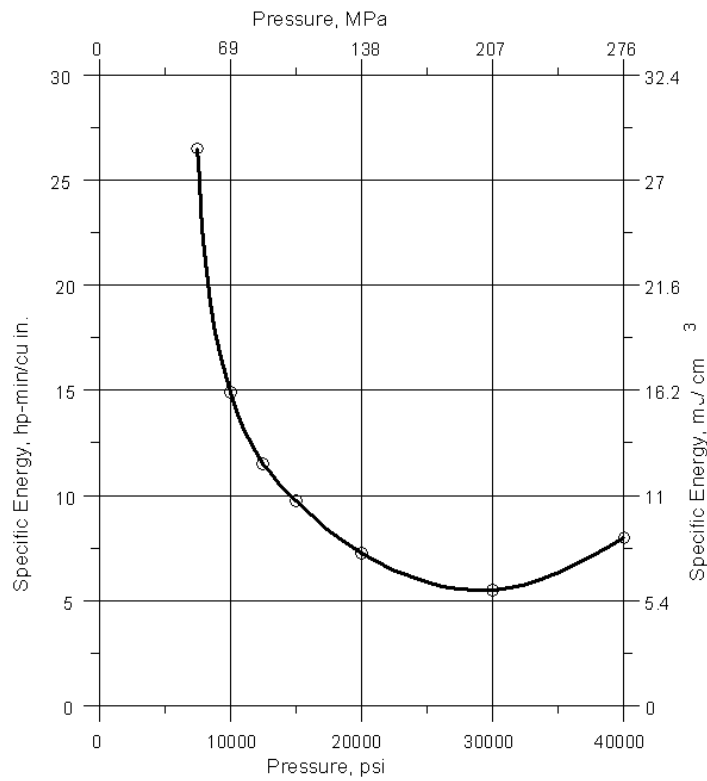

**Relationship of Pressure and Efficiency in Rubber Test Samples
Figure 3.**

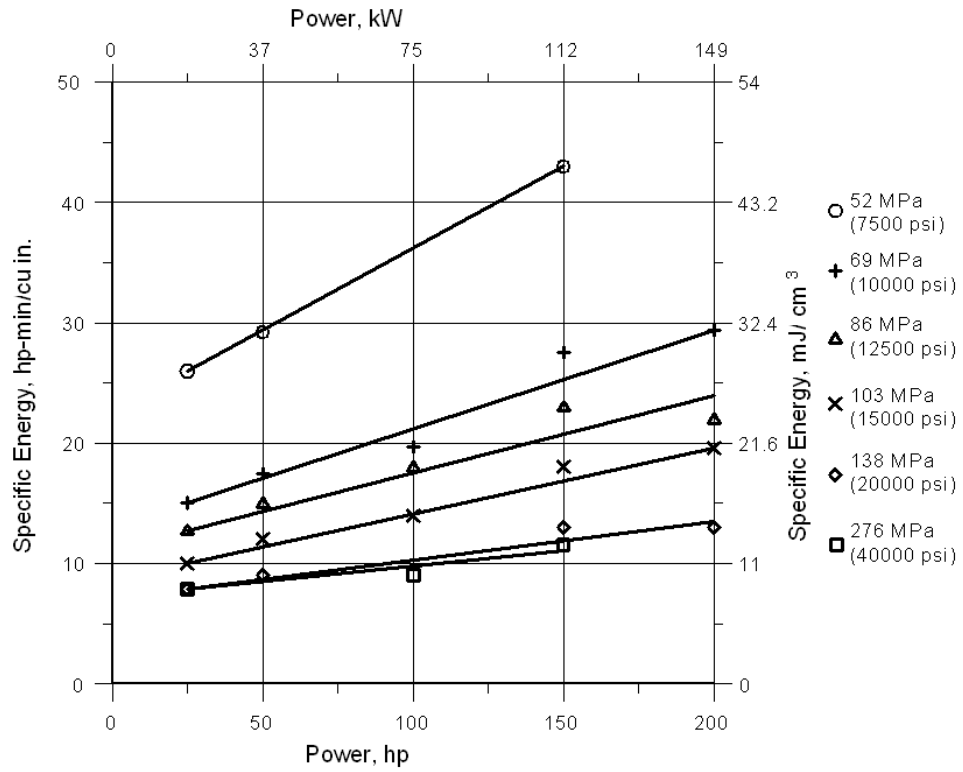

**Effect of Increasing Power at the Pressures Tested in Concrete
Figure 4.**

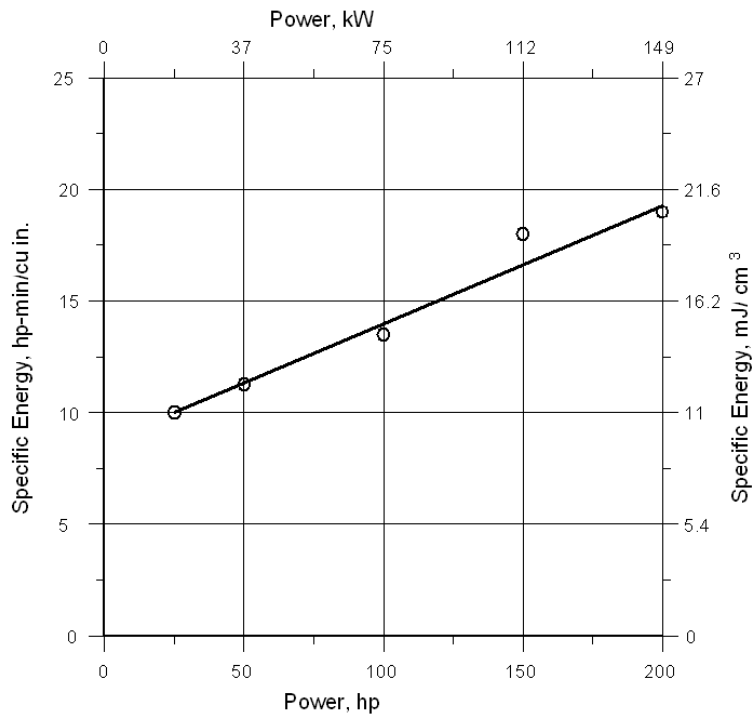

**Average Effect of Increasing Power in Concrete
Figure 5.**

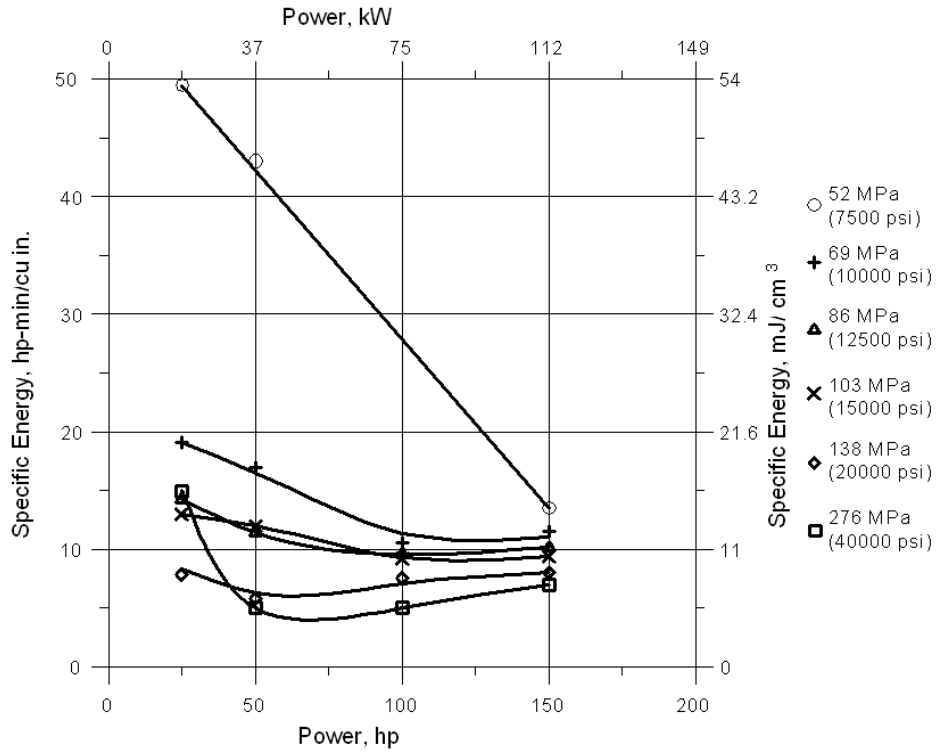

Effect of Increasing Power at the Pressures Tested in Rubber
Figure 6.

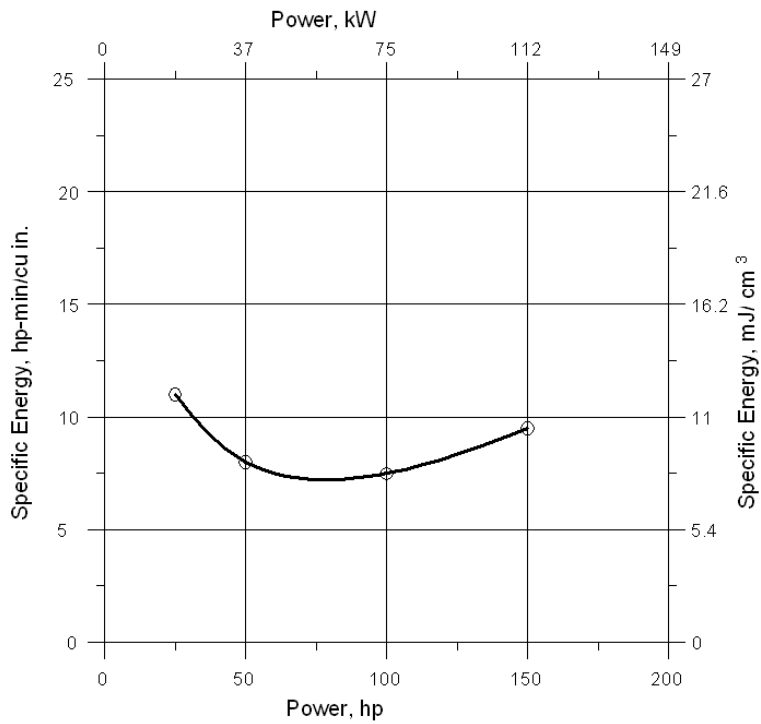

Average Effect of Increasing Power in Rubber
Figure 7.

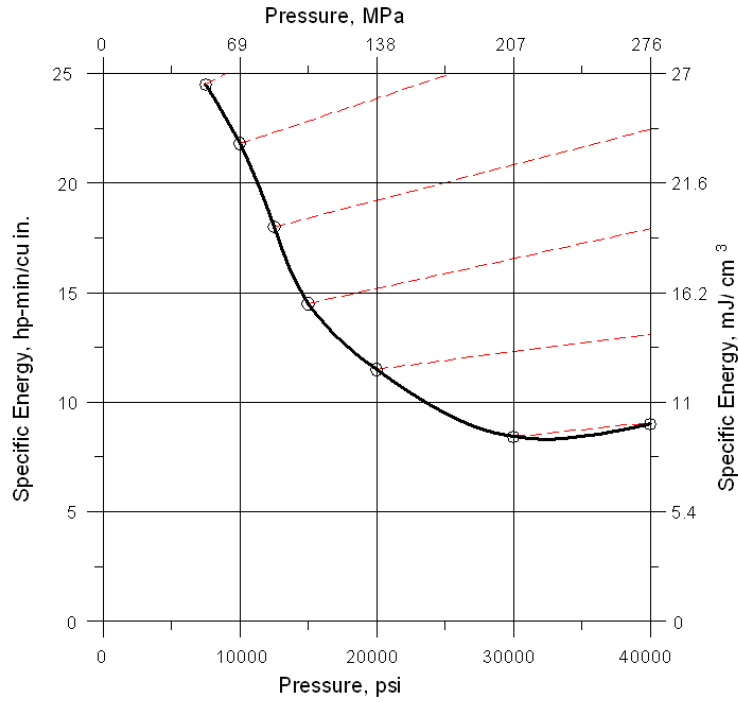

**Slope of Curves for Increasing Flow Efficiency Overlaid on Pressure Curve for Concrete
Figure 8.**

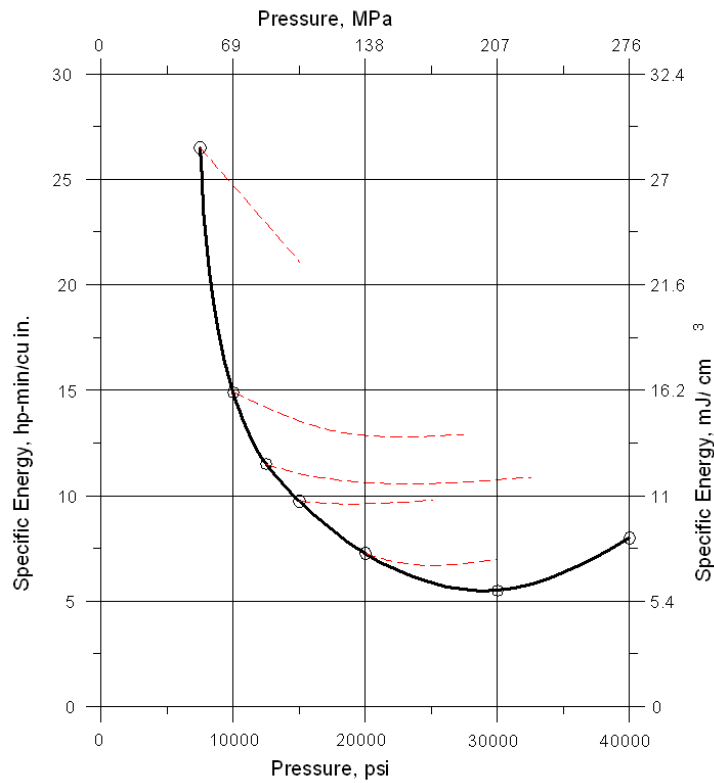

**Slope of Curves for Increasing Flow Efficiency Overlaid on Pressure Curve for Rubber
Figure 9.**