

WARTHOG® Self-Rotary Swivel (WU-3/8,-1/2,-3/8-BSP,-1/2-BSP)

US Patent No. 7635096,
8006920, 8016210 & D638912
Other Patents Pending

The **WU** is a self-rotating swivel designed for cleaning 3" to 6" pipes. The tool can be used at operating pressures up to 4000 psi (275 bar). It has either a 3/8" NPT, 1/2" NPT, 3/8" BSPP or 1/2" BSPP pipe thread inlet. If a standard 3/8" NPT or BSPP hose end is used, it can pass through long radius elbows in 4" and larger pipe. If using the tool in 3" pipe a special shorter hose end is required to allow tool to travel through long radius elbows. Contact StoneAge for more information on the hose requirements. The tool does not use any bearings, seals, or lubricating fluid. Rotation is powered by the jet thrust. The head selected determines the flow rate; refer to the head options chart for specifications.

Operation:

Before connecting the tool to the end of the hose, flush the jetter hose to remove debris. **The most important item in maintaining the WU is keeping debris from entering the tool, which will prevent it from rotating.** Attach the tool to the end of the hose; we recommend using teflon tape to seal the threads. Note that there is a large O-Ring (WU 008) around the inlet. This O-Ring helps prevent the tool from getting caught on the rear edge when pulling the tool back out of the line. Position the tool within the pipe to be cleaned; bring the pump up to pressure, making certain that the Warthog begins to pull its way into the pipe. Once the pump is up to pressure, feed the Warthog at a reasonable rate to allow the jets time to clean the pipe. If roots are present, feeding at a slower rate will improve the cleaning results. Depending on the amount of debris in the pipe, it may be necessary to occasionally pull the Warthog back toward the pipe entrance to prevent large buildups behind the tool.

When finished cleaning, shut down and secure pump before removing Warthog from line. If the Warthog will be removed from the line and stored for more than several days, blow out water with compressed air and spray a light oil such as WD-40 into the tool.

Troubleshooting:

Head will not rotate: Spray a light oil such as WD-40 into the tool and rotate head by hand until it turns freely again. Make sure that the jets in the head are not plugged. If the tool still does not rotate after trying this several times, it may need to be disassembled and cleaned on the inside. To do this requires a socket wrench (found in StoneAge Tool Kit WV 612) inserted into the rear of the shaft to remove the head from the shaft. Begin by removing the O-ring (WU 008) and the Retaining Ring (WU 010). Pull the Inlet Nut (WU 002-P6,P8,BSPP6,BSPP8) out of the Body (WU 003). Using the socket wrench, unscrew the Shaft (WU 001) from the Head (WU 040). Make sure the two small holes in the tapered face of the shaft are cleaned out; debris plugging these holes is the most likely cause of the tool not rotating. If the outside of the shaft is badly worn, it needs to be replaced.

NOTE: Whenever reassembling tool, apply 2-4 drops of Loctite #262 Red (StoneAge p/n BA 185) to the threads on the Head prior to screwing it into the Shaft. Care must be taken not to allow excess Threadlocker into the internal shaft bore below the female threads or onto the tapered external surface of the shaft. Torque to 60 to 100 in-lbs using socket wrench (available from StoneAge as p/n WV 181).

Head Options

Part	Front Jet	Back Jets	Flow (w/ 250 ft of 3/8" Hose @ 2 kpsi - 4 kpsi)	Flow (w/ 500 ft of 1/2" Hose @ 2 kpsi - 4 kpsi)
WU-040-A	.038	2 x .076	11.5 - 16 gpm	13 - 18.5 gpm
WU-040-B	.035	2 x .070	10.5 - 15 gpm	11.5 - 16.5 gpm
WU-040-C	.032	2 x .063	9 - 13 gpm	10 - 14 gpm
WU-040-D	.028	2 x .055	7.5 - 11 gpm	8 - 11.5 gpm
WU-040-E	.024	2 x .047	6.5 - 9 gpm	6.5 - 9.5 gpm
WU-040-F	.020	2 x .036	5 - 7 gpm	5 - 7.5 gpm

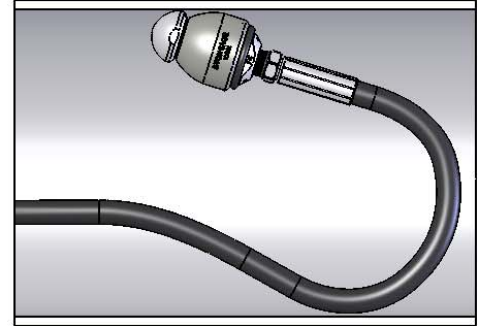
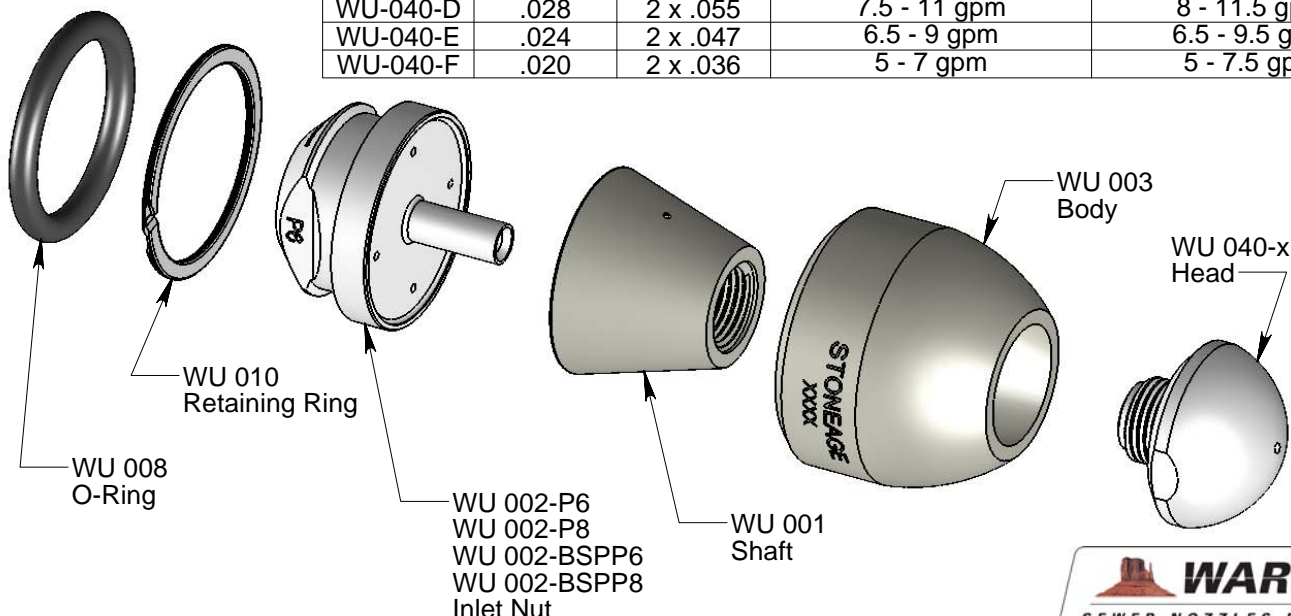

SAFETY!

If the WU is being used in pipes larger than 4 inch diameter, a rigid stinger should be installed between the tool inlet and the hose end; otherwise the tool can turn around and come back toward the operator, causing serious injury or death.

