

# UH Swivel (UH-H9H6, UH-H9G12)

## Description:

The **UH** swivel was designed to convey high pressure water from a stationary line to a powered rotating or twisting assembly. It is typically used on lancing machines, surface cleaning machines, and hose reels. The swivel requires a torque of 25 to 90 in-lb to rotate.

The **UH** swivel is rated for 40,000 psi working pressure, and a maximum rotation speed of 1500 rpm. It has a flow capacity rating of Cv = .5. To determine pressure loss thru the swivel at a given flow, divide the flow by the Cv and square the result. This is the pressure drop in psi.

<b>Operating Pressure Range</b>	20,000 - 40,000 psi
<b>Inlet Connection</b>	9/16 HP
<b>Rotation Speed, Max</b>	1,500 rpm
<b>Shaft Connection</b>	3/8 HP or G12
<b>Torque Required</b>	25 - 90 in-lb
<b>Flow Rating</b>	0.5 Cv

A single high pressure seal is used to provide leak free operation. The seal life will vary depending on the rotation speed. Higher rotation speeds result in shorter seal life. The high pressure seal is considered a wear item, and can be replaced easily and inexpensively.

All UH models have a 9/16 High Pressure Autoclave female inlet connection; straight or 90 degrees. The UH-H9H6 has a 3/8 High Pressure Autoclave male shaft connection; the UH-H9G12 has an O-Ring seal on the shaft connection.

## Operation:

If the swivel will be used at rotation speeds above 500 rpm, the swivel should be allowed a 1/2 hour break-in period where the swivel is run at operating pressure, but with a maximum rotation speed of 500 rpm. The swivel should never be rotated without water passing thru.

Use anti-seize on all threaded connections to prevent galling. Grease the swivel after 100 hours use, depending on rotation speed and service conditions.

## Troubleshooting:

**Seal Leak:** the swivel seal may intermittently leak a little bit. If the leak becomes continuous at operating pressure, the high pressure seal should be replaced.

**Seals wear out quickly:** inspect the portion of the shaft that passes through the bronze backup. If it appears galled, or the inside of the backup is galled, the shaft needs to be lightly polished to remove the bronze buildup (but not polished enough to remove the coating) and the bronze backup needs to be replaced. If seals are wearing quickly but the above has not happened, the bronze backup is worn oversize and needs to be replaced.

## Maintenance: \*Blow out all water with compressed air before storing tool!

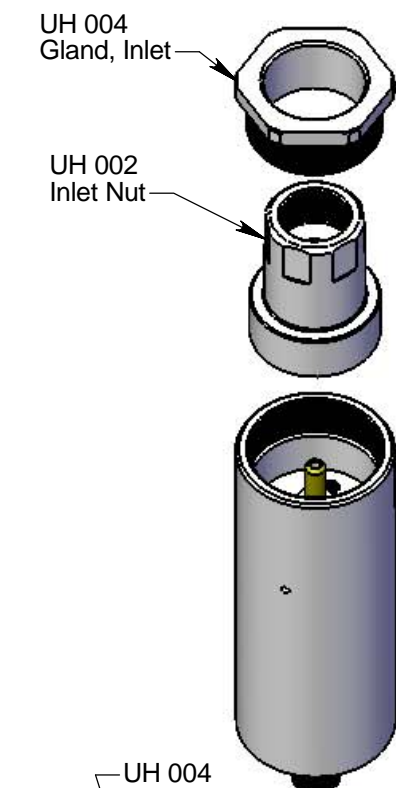

### High Pressure Seal Maintenance:

1. Unscrew the Inlet Gland from the Body.
2. Pull the Inlet Nut straight out of the Body. The H.P. Seal will likely stay inside the Inlet Nut.
3. Use a 3/16  $\phi$  or 10-24 screw to push out the Knockout and the H.P. Seal.
4. Apply grease to the outside of a new H.P. Seal, and apply grease to the shaft end where the seal will sit.
5. Drop the Knockout into the Inlet Nut; push the H.P. Seal into the Inlet Nut, just until flush with face of nut.
6. Place Inlet Nut into Body.
7. Install and tighten the Inlet Gland.

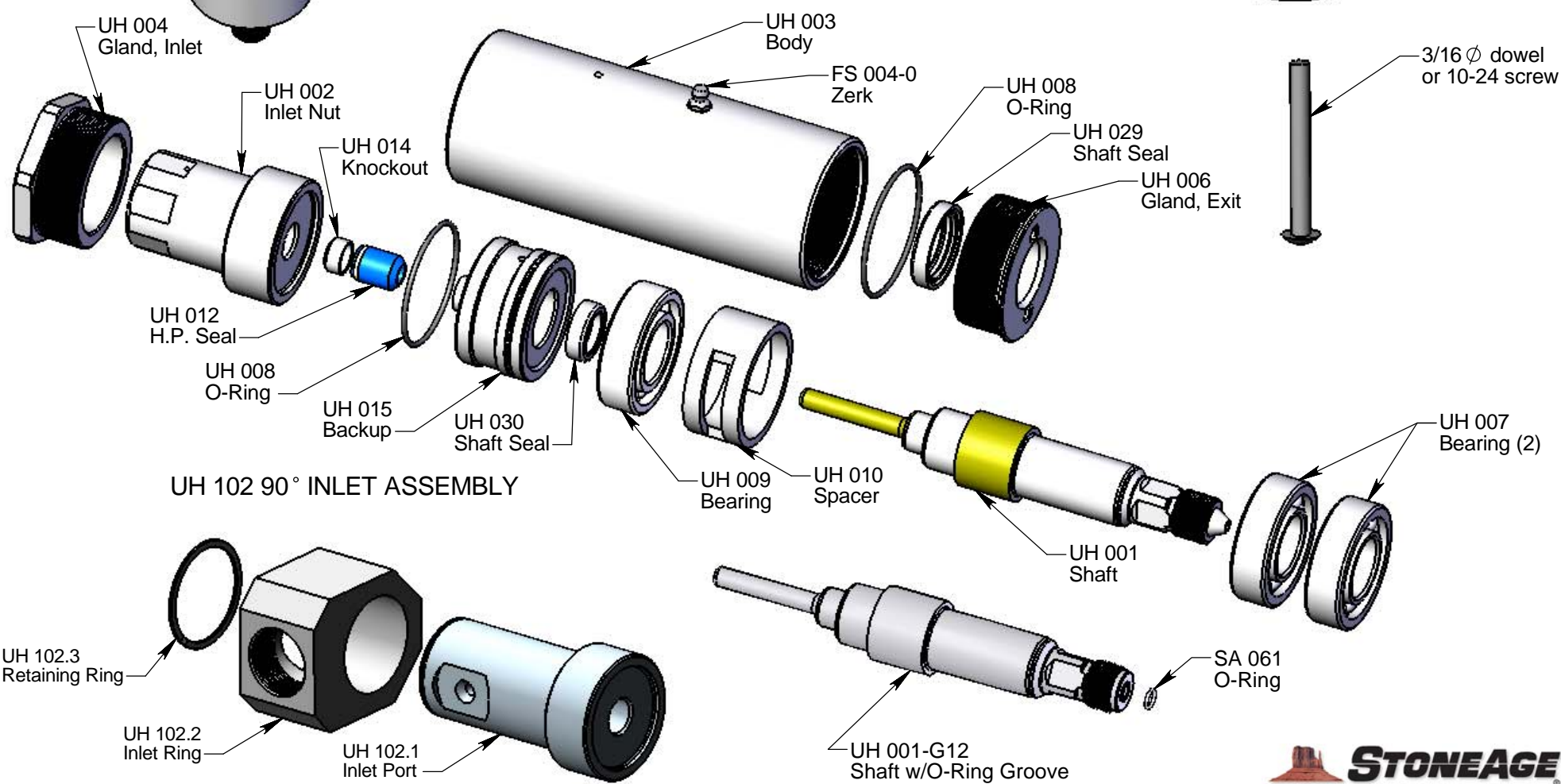
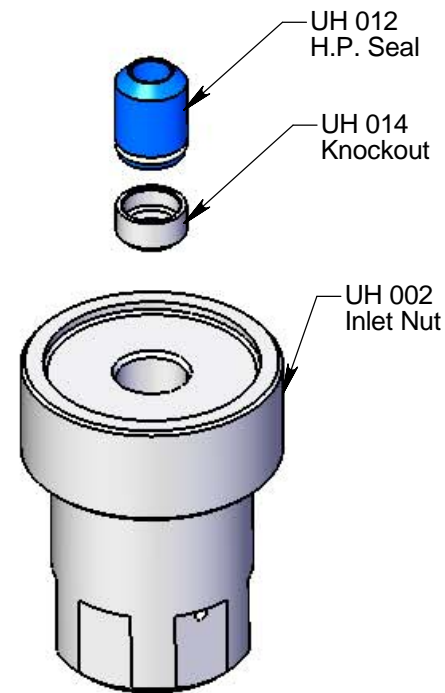

# UH Swivel

## Disassembly:

1. Remove the Inlet Gland (UH 004) from the Body (UH 003).
2. Pull the Inlet Nut (UH 002) from the Body. The High Pressure Seal (UH 012) will likely stay inside the Inlet Nut.
3. Thread two 1/4-20 bolts into the Backup (UH 015). Pull equally on the bolts to remove the Backup from the Body.

4. Push the Shaft (UH 001) out of the Body. The bearings should come out with the shaft.
5. Press the bearings (UH 007, UH 009) off of the Shaft. Use the slots in the Spacer (UH 010). Be careful not to damage the coated (gold colored) section of the shaft.
6. Inspect the coated portion of the shaft for wear or grooving. Replace if badly grooved.
7. Inspect the Shaft Seals (UH 029, UH 030) for damage. Remove them only if they need replacing. The Exit Gland (UH 006) can be removed from the Body to make replacing the Shaft Seal (UH 029) easier.

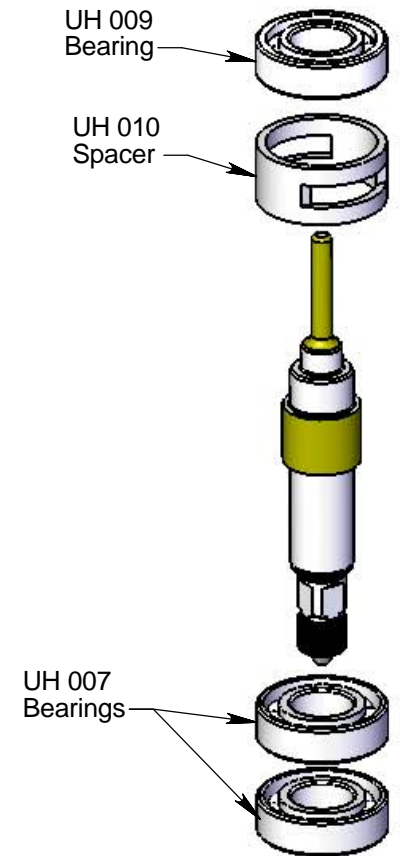
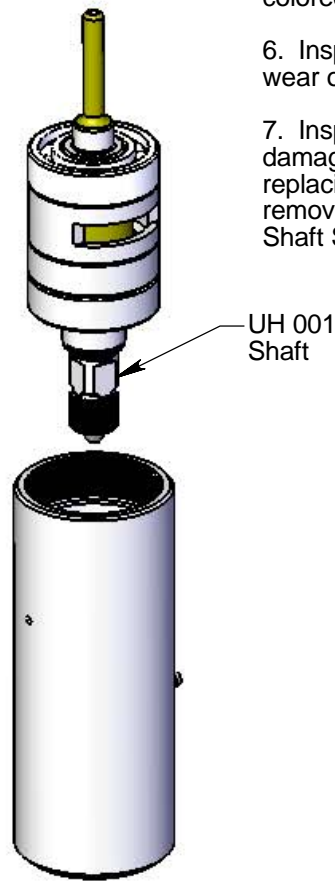
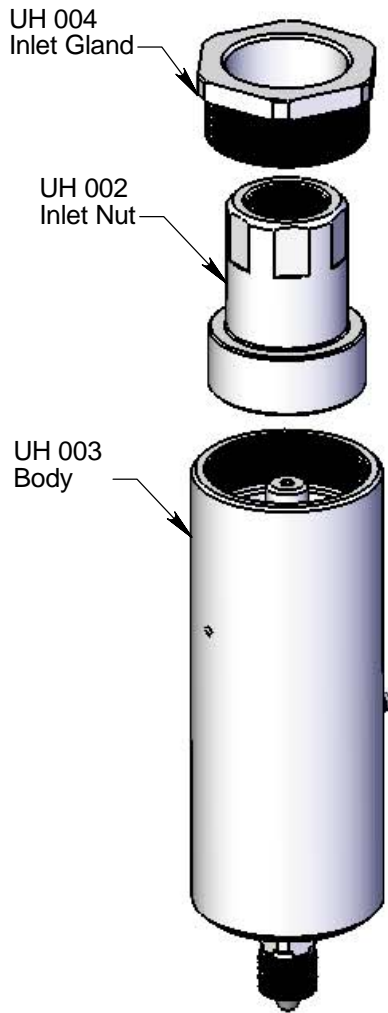

## Assembly:

1. Install Bearings (UH 009, UH 007) and Spacer (UH 010) on Shaft (UH 001). Note that the two bearings (UH 007) must be installed in the correct direction.
2. If the Exit Gland (UH 006) was removed, thread it into the correct end of the Body. It goes in the end furthest from the weep holes.
3. Slide the shaft with bearings into the body.

4. Drop the knockout (UH 014) into the Inlet Nut (UH 002).
5. Apply grease to the High Pressure Seal (UH 012) and push it into the Inlet Nut. Note orientation.
6. Slide the Backup (UH 015) into the Body. It should go down against the top bearing.
7. Slide the Inlet Nut into the Body.
8. Install and tighten the Inlet Gland (UH 004)

