

40 kpsi UHS Swivel (UHS-H9H9, UHS-H9H9-L)

Description:

The **UHS** swivel was designed to convey high pressure water from a stationary line to a powered rotating or twisting assembly. It is typically used on lancing machines, surface cleaning machines, and hose reels. The swivel requires a torque of 15 to 50 in-lb to overcome the rotational drag of the high pressure seal while operating at working pressure.

The **UHS** swivel is rated for 40,000 psi (2800 bar) working pressure, and a maximum rotation speed of 1500 rpm. It has a flow capacity rating of Cv = .3. To determine pressure loss thru the swivel at a given flow, divide the flow by the Cv and square the result. This is the pressure drop in psi.

A single high pressure seal is used to provide leak free operation. The seal life will vary depending on the rotation speed. Higher rotation speeds result in shorter seal life. The high pressure seal is considered a wear item, and can be replaced easily and inexpensively.

The **UHS** swivel has a 9/16 High Pressure Autoclave female inlet connection, and the outlet has a 9/16 High Pressure Autoclave LH male shaft connection.

Maximum Operating Pressure	40,000 (2800 bar)
Inlet Connection	9/16 HP
Rotation Speed, Max	1,500 rpm
Shaft Connection	9/16 HP
Torque Required	15 - 50 in-lb
Flow Rating	0.3 Cv

Operation:

If the swivel will be used at rotation speeds above 500 rpm, the swivel should be allowed a 1/2 hour break-in period where the swivel is run at operating pressure, but with a maximum rotation speed of 500 rpm. The swivel should never be rotated without water passing thru.

Use anti-seize on all threaded connections to prevent galling. Grease the swivel whenever the H.P Seal needs replacement, depending on rotation speed and service conditions.

Troubleshooting:

Seal Leak: the swivel seal may intermittently leak a little bit. If the leak becomes continuous at operating pressure, the high pressure seal should be replaced.

Seals wear out quickly: inspect the portion of the shaft that passes through the bronze backup. If it appears galled, or the inside of the backup is galled, the shaft needs to be lightly polished to remove the bronze buildup (but not polished enough to remove the coating) and the bronze backup needs to be replaced. If seals are wearing quickly but the above has not happened, the bronze backup is worn oversize and needs to be replaced.

Maintenance: *Blow out all water with compressed air before storing tool!

High Pressure Seal Maintenance:

1. Unscrew the Inlet Nut from the Body.
2. The H.P. Seal will likely stay inside the Inlet Nut.
3. Use a 3/16 ϕ nail head or 10-24 screw to pull the H.P. Seal out of the Inlet Nut.
4. Apply grease to the outside of a new H.P. Seal, and apply grease to the shaft end where the seal will sit.
5. Push the H.P. Seal into the Inlet Nut, just until flush with face of nut. The chamfered end should face out.
6. Carefully insert the Inlet Nut with H.P. Seal over the end of the shaft and screw it into the body. Tighten to 40 ft-lbs.

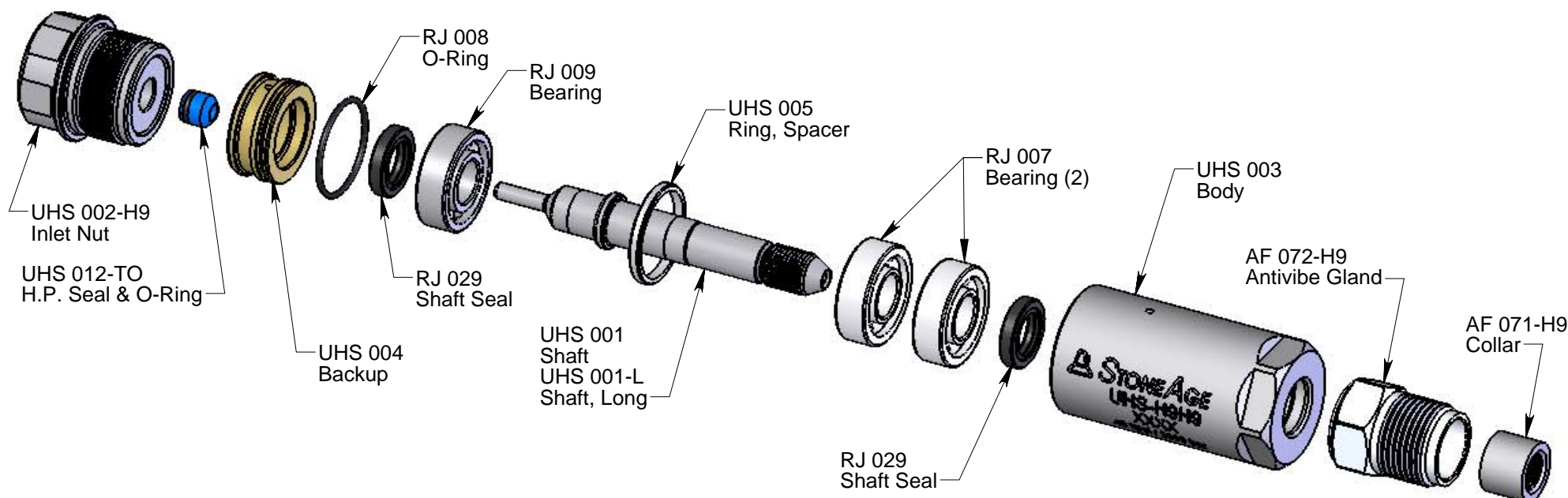
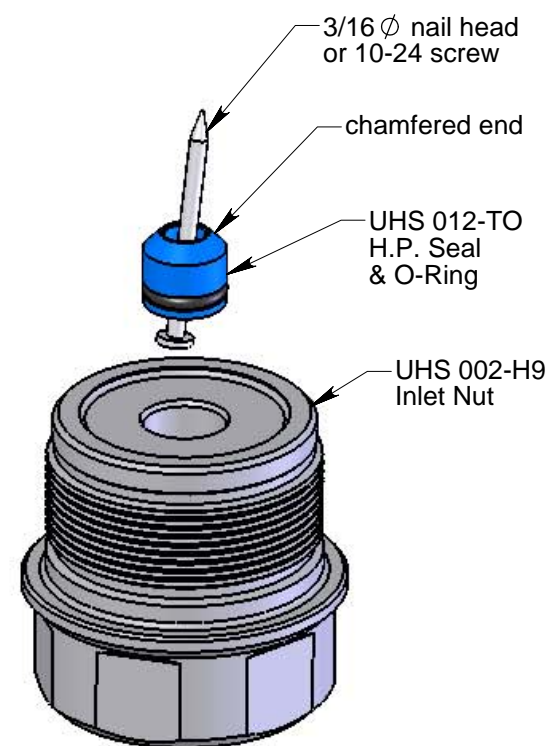

40 kpsi UHS Swivel (UHS-H9H9, UHS-H9H9-L)

Disassembly:

1. Remove the Inlet Nut (UHS 004-H9) from the Body (UHS 003). The High Pressure Seal (UHS 012-TO) will likely stay inside the Inlet Nut.
2. Remove the Collar (AF 071-H9) and the Antivibe Gland (AF 072-H9) from the Shaft.
3. Use a 3/16 ϕ nail head or 10-24 screw to hook the back side of the H.P. Seal and pull the H.P. Seal out of the Inlet Nut.

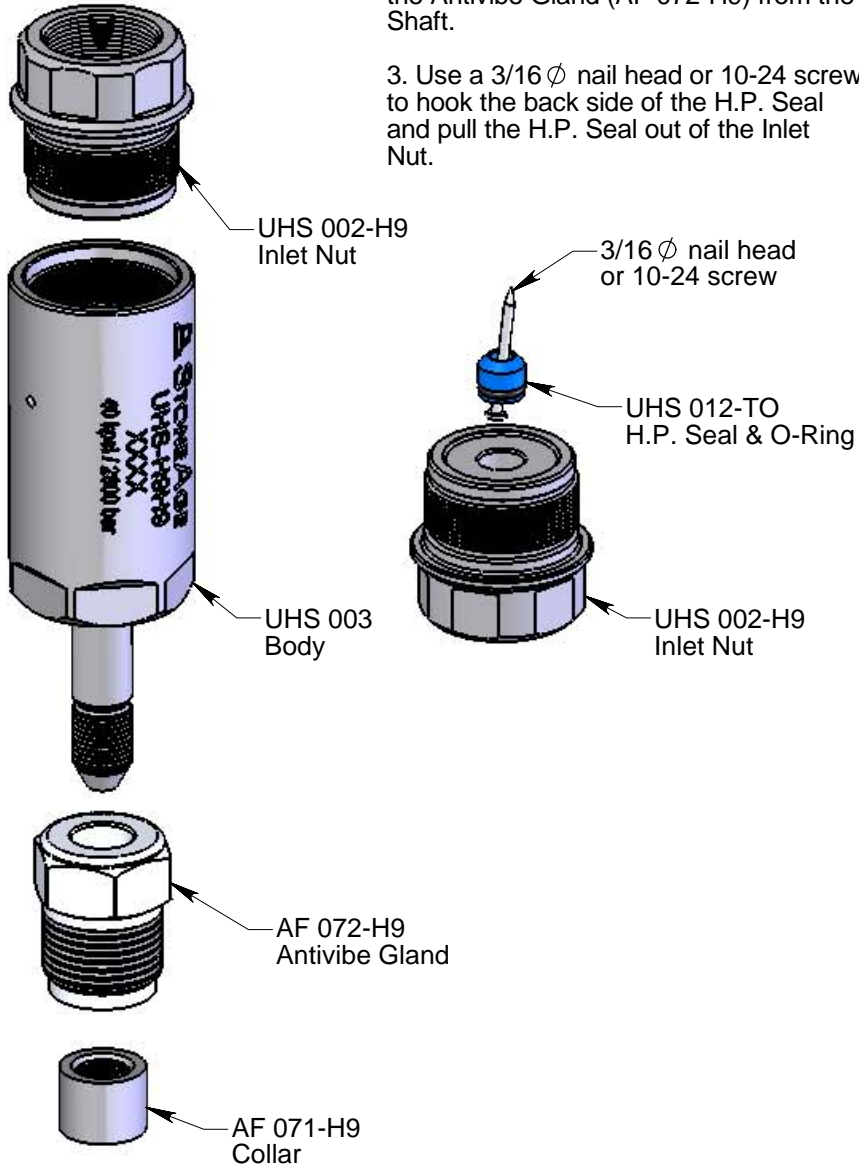

4. Push the Shaft (UHS 001 or 001-L) out of the Body. The bearings should come out with the shaft.
5. Remove the Backup (UHS 004) from the Shaft.
5. Press the bearings (RJ 009 & 2x RJ 007) and the Spacer Ring (UHS 005) off of the Shaft. Be careful not to damage the coated surface of the shaft (the smaller diameter shiny portion).
6. Inspect the coated portion of the shaft for wear or grooving. Replace if badly grooved.
7. Inspect the Shaft Seals (RJ 029) in the Backup and the Body for damage. Remove them only if they need replacing.
8. Inspect the O-Ring (RJ 008) in the groove on the outside of the Backup. Remove if it is damaged.

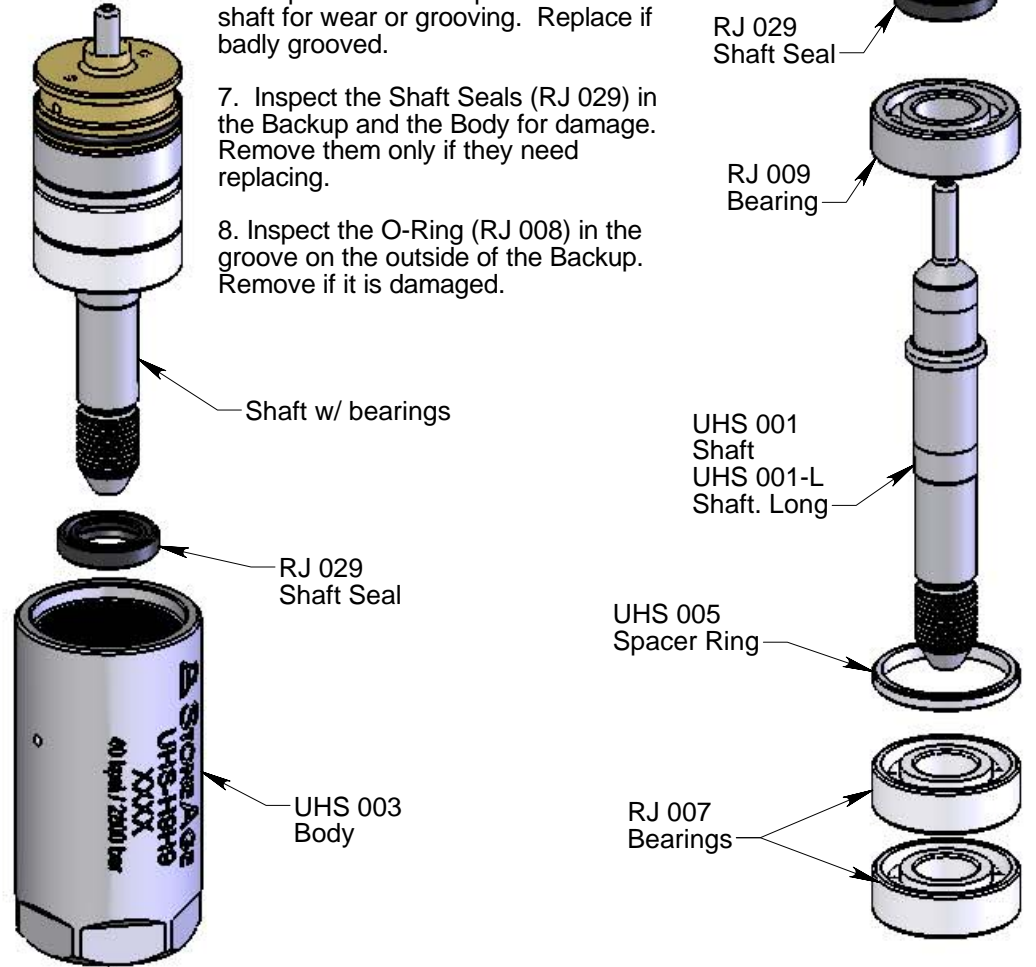

Assembly:

1. Install Shaft Seal (RJ 029) into the Body. Note the lip with the spring goes in last. Grease the lips of the Seal.
2. Install Shaft Seal (RJ 029) into the Backup. Note the lip with the spring goes in first. Grease the lips of the Seal.
3. Place the O-Ring (RJ 008) into the groove on the outside of the Backup. Grease the outside of the O-Ring.

4. Prior to installation, pack bearings liberally with grease on both sides.
5. Install Bearings (RJ 009 & 2x RJ 007) and Spacer (UHS 005) onto Shaft (UHS 001 or 001-L). Note that the two lower bearings (RJ 007) must be installed with the wide inner race in the correct direction.
6. Carefully slide the Backup onto the Shaft with the Shaft Seal towards the bearings.

7. Gently slide the Shaft assembly with Bearings into the Body.
8. Apply grease to the outside of the H.P. Seal and press into the Inlet Nut, just until flush with face of nut. The chamfered end should face out.
9. Apply grease to the seal surface of the shaft (small diameter).
10. Apply antisieze to the threads on the Inlet Nut. Carefully insert the Inlet Nut with H.P. Seal over the end of shaft and screw it into the Body. Tighten to 40 ft-lbs.
11. Slide Antivibe Gland (AF 072-H9) onto shaft, and screw the Collar (AF 071-H9) on until shaft threads are just visible past the cone of the shaft.

