

Tomcat TMC Swivel

Description:

The **Tomcat** is a self-rotating swivel designed for coil tubing well service. The powerful rotating jets cover a large area for efficient cleaning. Jet reaction force powers rotation of the head. An internal centrifugal speed control maintains rotation speeds of 150 to 200 rpm. The Tomcat uses a high viscosity synthetic gear oil for lubrication, such as Texaco Pinnacle 220, Chevron HiPerSyn 220 or equivalent.

The tool has a straight flow-through design with a leak-free high pressure seal so pump power is not wasted. It has a 1" AMMT inlet thread. The tool can be used at temperatures up to 200°C, and can be used with up to 30% HCL and Nitrogen injection. (Note: if used with HCL, flush tool with clean water after use.)

If the Tomcat will be used with high external borehole pressures, make certain that the body of the tool is completely full of lubricating fluid; air pockets are compressible and this could lead to oil seal failure and loss of lubrication.

The Tomcat can be used at operating pressures of 1000 to 5000 psi and flow rates of .7 to 1.33 bpm (30 to 56 gpm).

The standard nozzle head has five ports with 1/8 npt threads; one at 15 degrees forward, two at 45 degrees forward and two at 90 degrees to the axis of rotation. Some of the ports may be plugged in a balanced pattern to concentrate the flow in a particular direction. Alternate head porting patterns may be added to the same head to accommodate different flow rates.

Troubleshooting:

If the head will not rotate when at operating conditions, check head by hand to make sure it rotates freely. If it does not rotate freely by hand, the tool needs to be disassembled and repaired.

If the head rotates freely by hand, check the jet sizes and calculate pressure loss thru the coil tubing and check with your distributor or StoneAge to make certain there is enough jet torque to provide rotation.

If the head rotates too fast, clean out old lubricating fluid and replace with fresh lubricant.

Maintenance:

The Tomcat uses synthetic gear oil for a lubricant. To top off the tool with lubricant, follow steps below. If the tool is being rebuilt or the seal replaced, the lubricant may be poured directly into the body around the shaft before the inlet nut is installed. Once the inlet nut is installed, it is recommended to use the syringe with the port screw ports to completely remove all air bubbles. To replace the high pressure seal, follow the steps on the right.

1. Remove both Port Screws (BJ 026).
2. Fill the syringe (BC 410) with lubricant.
3. Thread the syringe into one of the two ports.
4. Hold the tool at an angle so the port with the syringe is lower.
5. Squeeze fluid into the tool until all air bubbles stop coming out.
6. Remove syringe, install Port Screws.

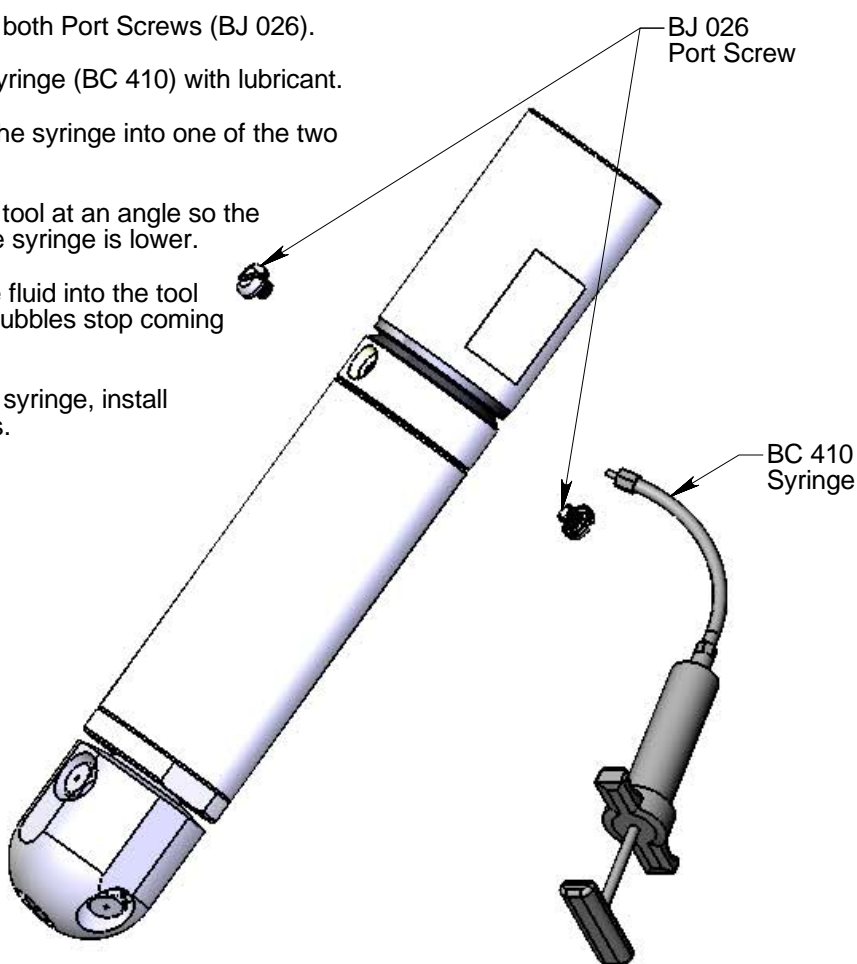

Detailed View of Seat & H.P. Seal

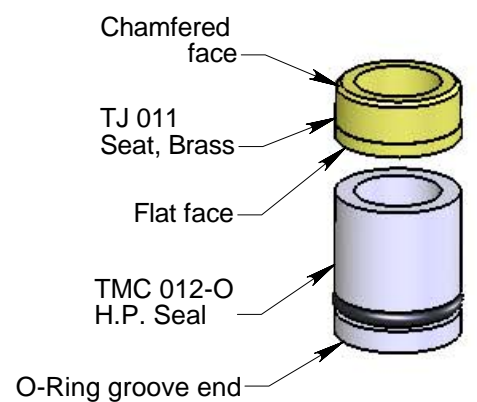

To replace the high pressure seal:

1. Unscrew the Inlet Nut (TMC 002).
2. Remove the old Seat (TJ 011) and H.P. Seal (TMC 012-O).
3. Apply grease to and install new H.P. Seal into the shaft with the O-Ring groove end going in first. Do not press all the way into the shaft bore.
4. Install new Seat (TJ 011) with the chamfered face toward Inlet Nut. Press in just far enough so that the seat is captured in the shaft bore.
5. Thread Inlet Nut into Body; tighten to 50 ft-lb.

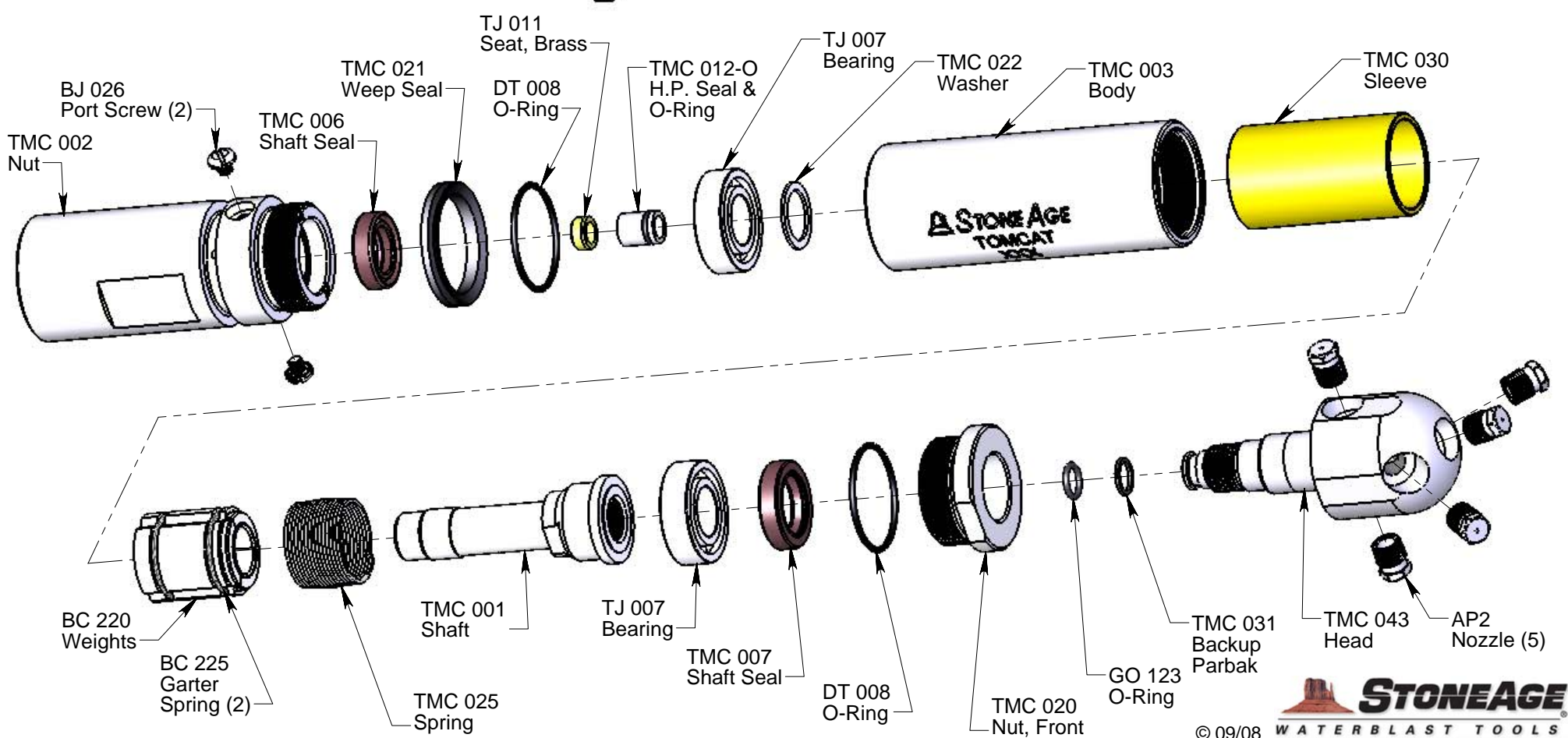
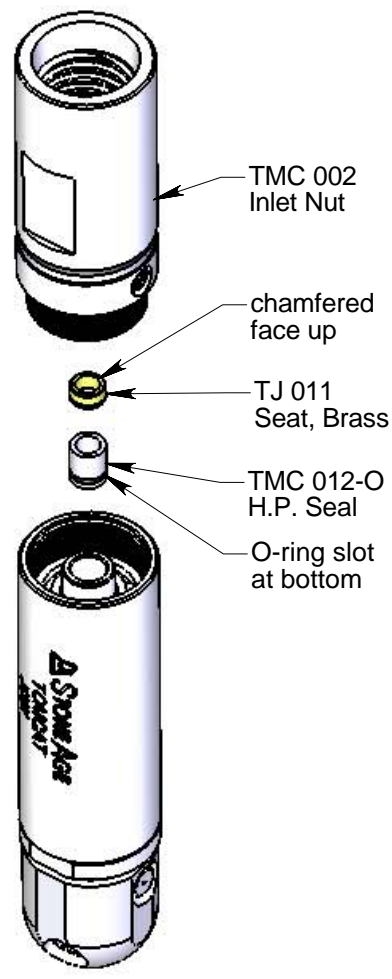

Tomcat TMC Swivel

Disassembly:

1. Unscrew the Inlet Nut (TMC 002) from the body.
2. Remove the Seat (TJ 011) and the H.P. Seal (TMC 012-O) from the bore of the shaft.
3. If the Shaft Seal TMC 006 is damaged, remove it from the Nut using snap ring pliers.

4. Unscrew the Body (TMC 003) from the assembly while holding the Front Nut (TMC 020).

5. Pull the Bearing (TJ 007) from the Shaft. Remove the Washer (TMC 022).

6. Pull the Sleeve (TMC 030) off of the assembly.

7. Unhook the Spring (TMC 025) from the holes in the Shaft and the Weights; slightly expand and remove the Weights (BC 220) and Spring (TMC 025) from the Shaft. Leave the Weights together.

8. Unscrew the Shaft (TMC 001) from the Head (TMC 043) and pull up on the Front Nut (TMC 020) to remove it and the Bearing (TJ 007) from the Head.

9. If the Shaft Seal (TMC 007) is damaged, remove it from the Front Nut.

10. Inspect the O-Ring (GO 123) and Backup Ring (TMC 031) on the end of the Head. Remove them if they are damaged.

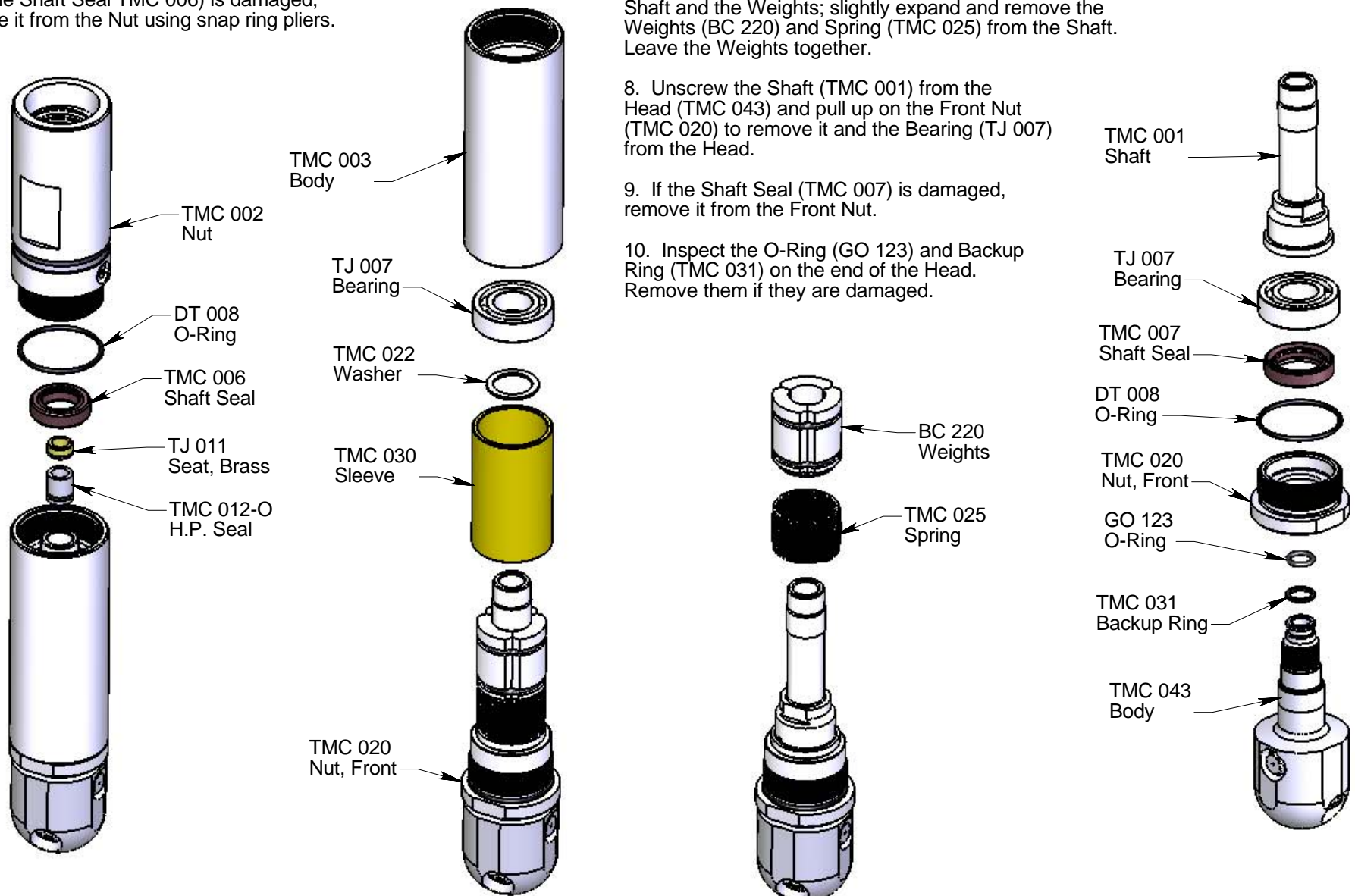

Assembly:

1. Install Backup Ring (TMC 031) and then the O-Ring (GO 123) on Head (TMC 043). Note order they sit. Apply anti-seize to threads and grease to O-Rings.

2. Install Shaft Seal (TMC 007) into Front Nut (TMC 020). Note direction of lip with spring. Install O-Ring (DT 008) onto Front Nut. Apply anti-seize to Front Nut threads. Apply Armour-All to lips of seal; slide Front Nut onto Head.

3. Install Bearing (TJ 007) on Head.

4. Thread Shaft (TMC 001) onto Head; tighten to 30 ft-lb.

5. Slide Spring (TMC 025) onto Shaft (TMC 001). Insert Spring end into hole in shaft; then slightly expand and slide Weights onto Shaft; insert other spring end into hole in Weights.

6. Slide Sleeve (TMC 030) over the assembly.

7. Place Washer (TMC 022) on top of Weights.

8. Slide Bearing (TJ 007) onto Shaft.

9. Slide Body (TMC 002) over assembly and thread onto Front Nut (TMC 020) and tighten hand-tight.

10. Install O-Ring (DT 008) onto Nut (TMC 002). Install Shaft Seal (TMC 006) into Nut. Note direction of lip with spring. Apply anti-seize to threads and Armour-All to lips of seal.

11. Fill the tool with lubricant to top of Bearing.

12. Install the H.P. Seal and Seat as shown in the Maintenance Section and thread Nut into Body. Install Port Screws. (BJ 026).

