

SM High Flow Swivels (SM-P16, SM-P20, SM-P16G, SM-P16L)

Available in 0° and 90° Inlets, for powered rotation up to 300 rpm

Description:

The **SM** swivels convey high pressure fluid from a stationary line to a rotating or twisting assembly. They are intended for use where an external motor/gearbox supplies power for rotation. This swivel may also be used on hose reels or where a hose connects to an assembly to aid in hose handling.

Two types of the SM swivel are available. The SM-P16 has 1" npt inlet and shaft connections, while the SM-P20 has 1-1/4" npt inlet and shaft connections. Both types are available with either a straight inlet connection (0 degree) or a 90 degree inlet.

The SM-P16 is rated for 12,000 psi and 300 gpm, and the SM-P20 is rated for 10,000 psi and 600 gpm. Maximum rotation speed is 300 rpm for both models.

A single high pressure seal is used to provide near leak free operation. It is long lived, but is considered a wear item. The seal can be replaced easily and inexpensively. The swivel may leak intermittently or after periods of non-use. This is normal for this type of seal design. Only if large continuous leaks occur should seal replacement be necessary.

Use Parker Thread-Mate or other anti-sieze and Teflon tape on all pipe thread connections. Grease the swivel after 80 to 100 hours of operation.

Troubleshooting:

Swivel will not rotate: Bearings need to be replaced. If there is water in them and they are corroded, also replace the shaft seals.

Seal Leak: The seal may leak initially up to several thousand psi, but should seal as pressure is increased. If operating pressure is reached and the seal is leaking continuously, the high pressure seal may need to be replaced. Refer to the maintenance below. Inspect the face of the inlet nut for pitting or grooves from erosion; if present, the inlet nut requires resurfacing or replacement.

Seals wear out quickly: The tool must be disassembled and inspected. The carbide seat should be checked for being installed in the right direction, and it should not have any chips or erosion marks on it. The bore of the shaft where the high pressure seal is located should be checked for grooving. If it is worn larger than .885" or larger than 1.060", the shaft will need to be replaced.

Maintenance: *Blow out all water with compressed air before storing tool!

A single high pressure seal is used to provide near leak free operation. It is long lived, but is considered a wear item. The seal can be replaced easily and inexpensively. The swivel may leak intermittently or after periods of non-use. This is normal. Only if large continuous leaks occur should seal replacement be necessary. Use anti-sieze and Teflon tape on all pipe thread connections. Grease the swivel after 80 to 100 hours of operation.

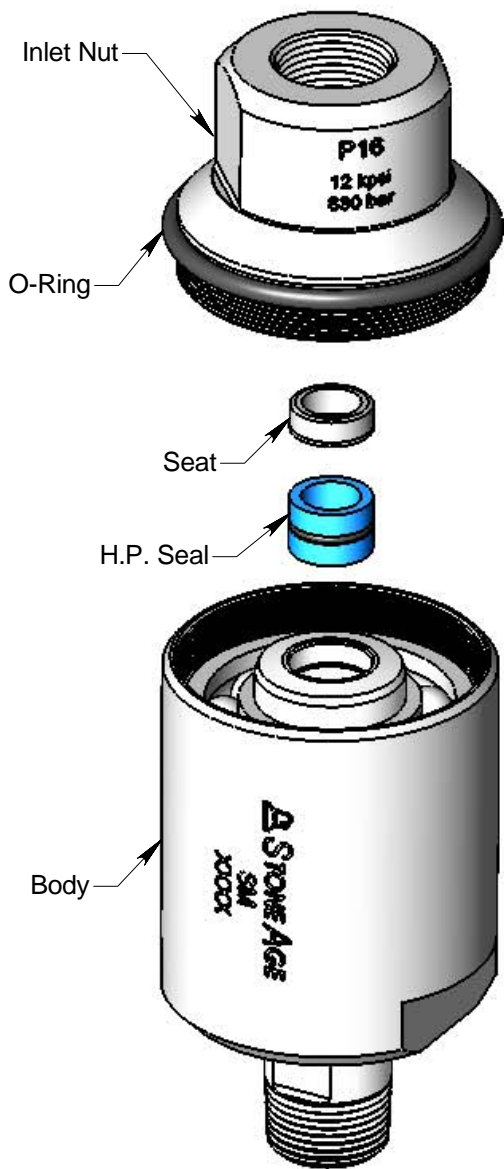

High Pressure Seal Maintenance:

1. Unscrew the Inlet Nut from the Body.
2. Lift out the Seat and H.P. Seal from the bore of the shaft.
3. Inspect the Seat for chips or erosion pits.
4. Apply grease to a new H.P. Seal, slide into bore of shaft until flush with shaft end.
5. Place Seat on top of H.P. Seal, with the flat face toward the seal as shown in detail. Push into bore of shaft just far enough to ensure that it stays centered.
6. Apply anti-sieze to threads of Inlet Nut; thread into Body, making sure that the Seat stays centered in bore of shaft. Tighten to 100 ft-lb.

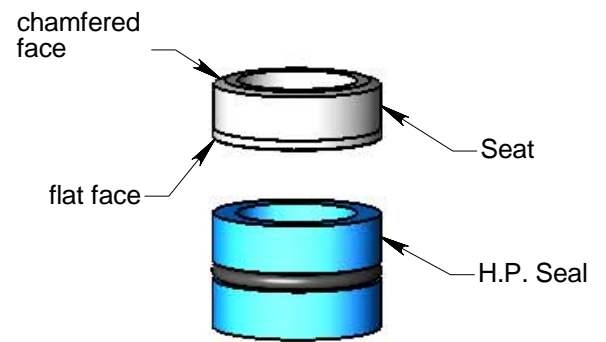

Note: first part ID shown is used in P16 Assembly; second part ID shown is used in P20 Assembly. If only one part ID is shown, it is the same for both models.

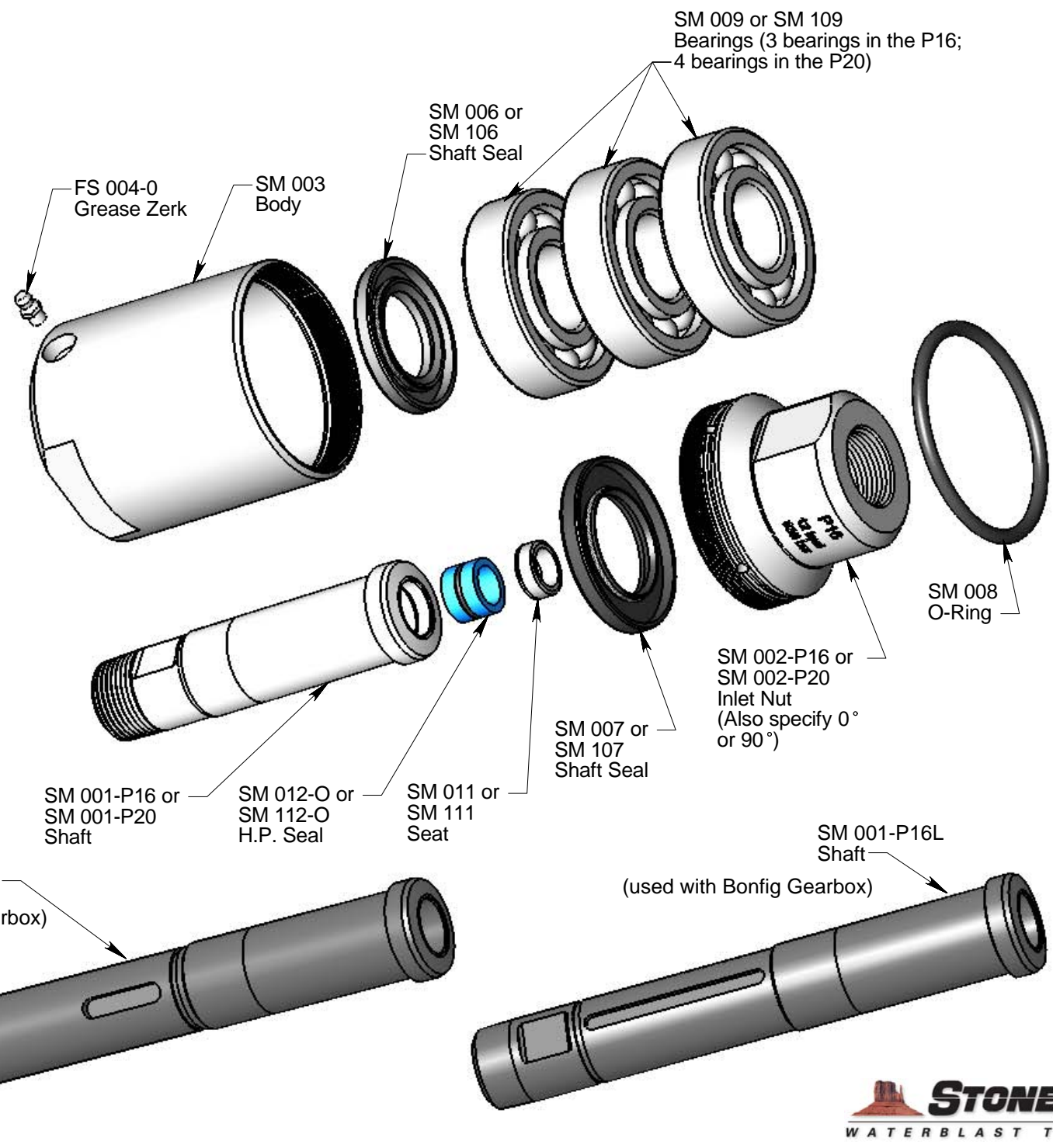

SM High Flow Swivels (SM-P16, SM-P20, SM-P16G, SM-P16L)

Disassembly:

1. Unscrew the Inlet Nut (SM 002) from the Body (SM 003).
2. Remove the Seat (SM 011-C) and H.P. Seal (SM 012) from the shaft bore.
3. Push the Shaft (SM 001), with bearings (SM 009), out of the Body.
4. Press the Bearings off of the Shaft.

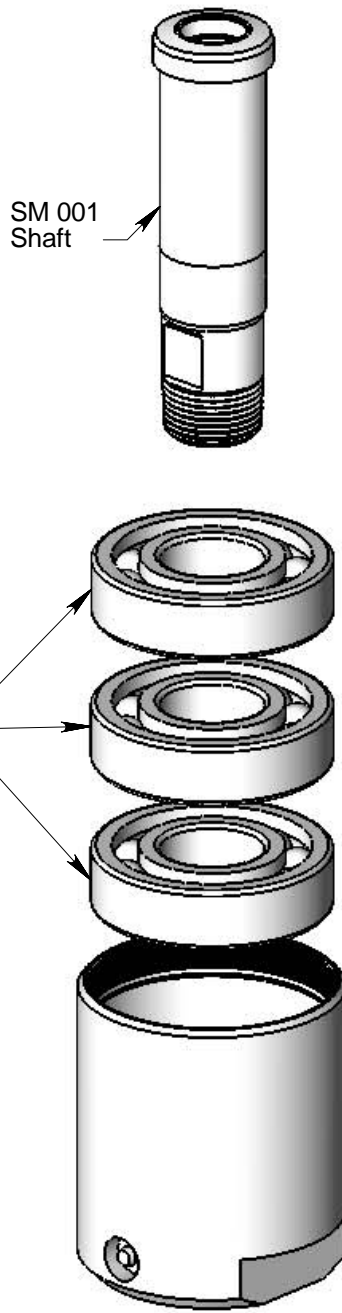
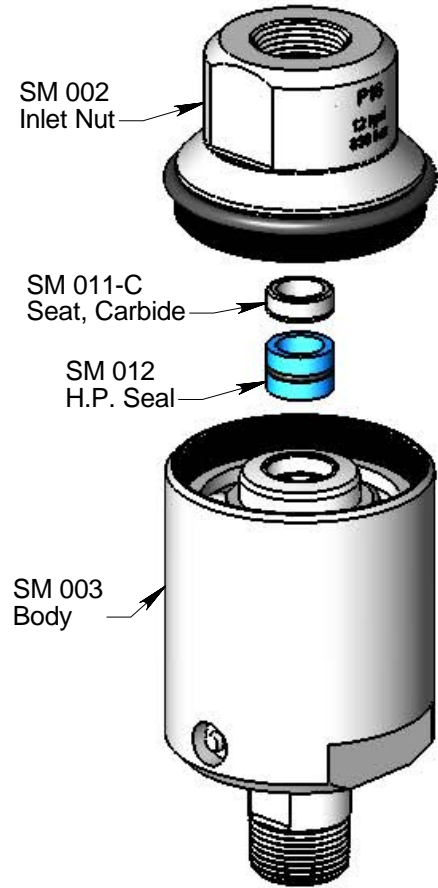

5. Remove the Shaft Seal (SM 007) from the Inlet Nut only if it is damaged and you intend to replace it.
6. Remove the O-Ring (SM 008) from the outside of the Inlet Nut.

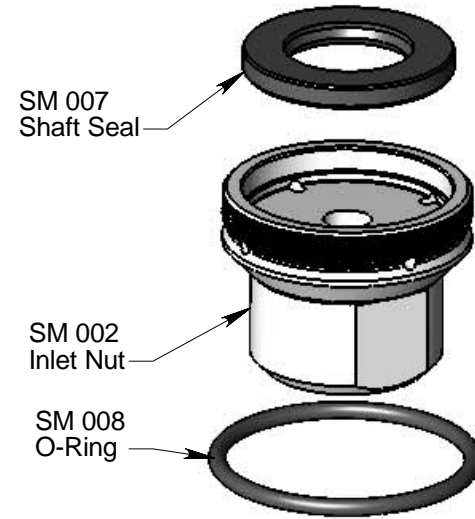

7. Remove the Shaft Seal (SM 006) from the Body only if it is damaged and you intend to replace it.



Assembly:

1. Install new Shaft Seals (SM 007) in Inlet Nut (SM 002) and in Body (SM 003). Note orientation of lip. Apply grease to the lips of the seals.
2. Place O-Ring (SM 008) in groove of Inlet Nut.

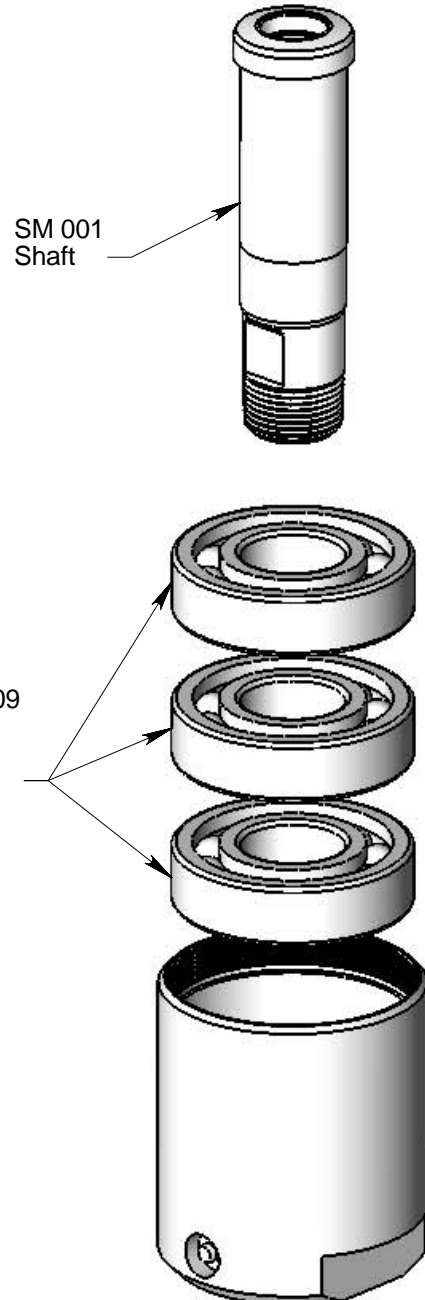
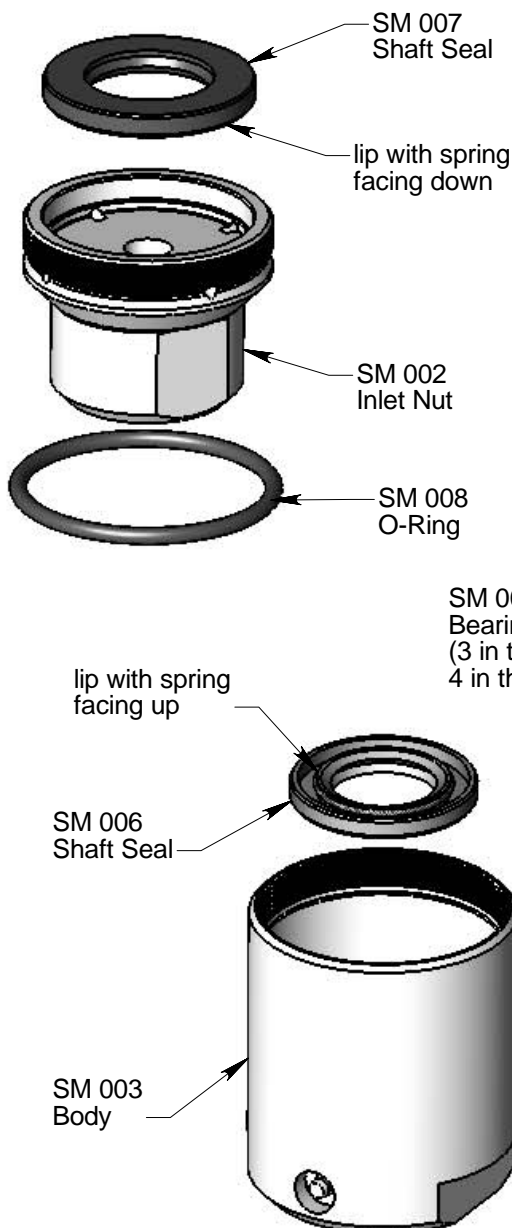

3. Grease each bearing and press onto Shaft (SM 003), one at a time.
4. Slide shaft with Bearings (SM 009) into Body (SM 003).
5. Apply grease to the H.P. Seal (SM 012) and install in shaft bore. Place flat side of Seat (SM 011-C) on top of H.P. Seal (see the Maintenance Section).
6. Apply anti-seize to threads of Inlet Nut (SM 002). Thread into Body, making sure that the Seat stays centered in bore of shaft. Tighten to 100 ft-lb.

