

# SG-30 Free Spinner

## Description:

The **SG-30 FREE SPINNER** is a surface cleaner that is rotated by the jet reaction force by angling one or more of the nozzle arms. It is typically mounted to a device that allows moving the unit across a surface or fixed in place over a moving surface such as a conveyor belt. The maximum pressure rating depends on the swivel and head; both units have a maximum flow capacity of 50 gpm, if proper support is used to withstand the reaction force produced by the jet thrust. The 15K version uses 1/2 npt ports in the manifold and 1/2 pipe for the arms; the swivel (SG-CCN-P12K-X) has a 3/4 npt inlet connection. The 22K model uses 3/4 medium pressure (autoclave) ports in the manifold and 3/4 medium pressure tubing for the arms; the swivel (SG-CCN-M12K-X) has a 3/4 medium pressure inlet connection. Both use 1/4 npt nozzles in the ends of the arms.

## Operation:

The assembly must be firmly mounted to support the jet reaction force, which could be several hundred pounds of thrust. Make sure the arms clear the surface being cleaned as well as any shields or guards. When trying to remove thick deposits of material or trying to remove material at large standoff distances it is better to use slower rotation speeds. If removing thinner coatings or milling or scarifying, use faster rotation speeds. Faster rotation speeds are also effective when trying to remove a coating or deposit without damaging the underlying substrate. Standard arm lengths provide either 18 inch or 24 inch jet paths, with a 95° bend so the jets are angled slightly inward. Custom arms can be made if different angles are desired. Jet path diameters down to 12 inches are possible but not recommended due to the difficulty of setting the rotation speed.

The angle of the nozzle arms should be adjusted to give speed adjustment. Refer to the chart which shows the angle that two arms should be set at to give a rotation speed of approximately 1000 rpm for the operating flow and pressure. If 4 of the arms are being angled, each arm should be angled 1/2 of the chart value. Increasing or decreasing the angle will give faster or slower rotation rates. Make sure that the head will rotate clockwise when viewed from the bottom, so as to tighten the head onto the shaft of the swivel. Tighten the arm clamp after adjusting the angle. The maximum safe rotation speed for the assembly is 1500 rpm.

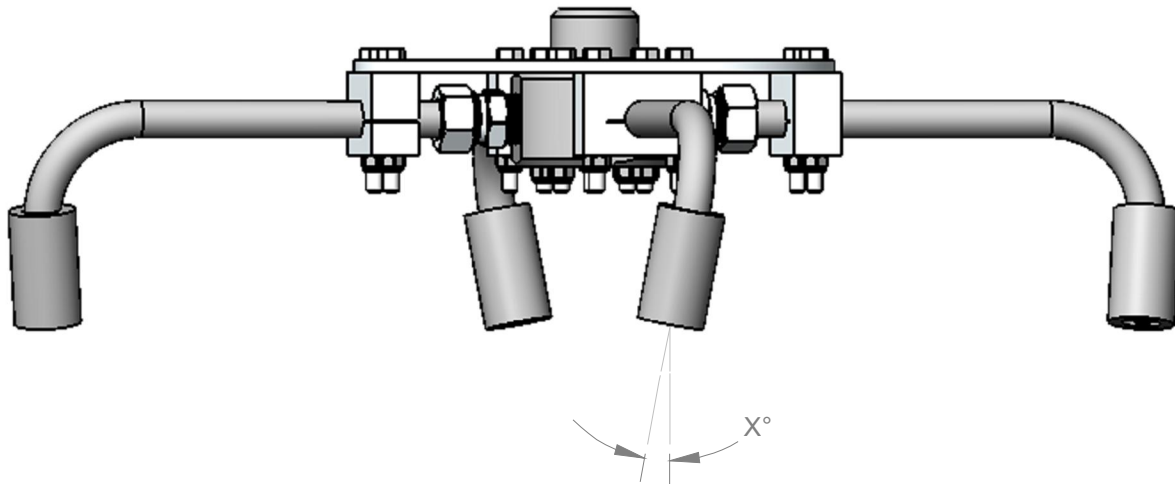

		Flow Rate, GPM					
		10	15	20	25	30	35
Pressure, PSI	22000	.024Ø 15°	.029Ø 10°	.035Ø 7°	.038Ø 7°	.042Ø 6°	.047Ø 5°
	20000	.024Ø 15°	.032Ø 9°	.035Ø 7°	.038Ø 7°	.042Ø 6°	.047Ø 5°
	15000	.029Ø 10°	.035Ø 7°	.038Ø 6°	.042Ø 6°	.047Ø 5°	.052Ø 4°
	10000	.032Ø 10°	.038Ø 7°	.042Ø 6°	.047Ø 5°	.052Ø 5°	.057Ø 4°
	5000	.038Ø 9°	.042Ø 8°	.052Ø 6°	.057Ø 5°	.063Ø 5°	.069Ø 4°
	.043Ø 8°		Orifice Diameter for pressure and flow with 4 jets. Angle of 2 arms for 1000 RPM				

## Maintenance:

Grease the swivel after every 100 hours of use; when the amount of leak from the swivel seal does not allow maintaining operating pressure, replace the high pressure seals; refer to the SG-CCN Swivel insert sheet. If the unit vibrates or shakes badly, check nozzles for plugging or wear, which creates unbalanced jet thrust and vibration.

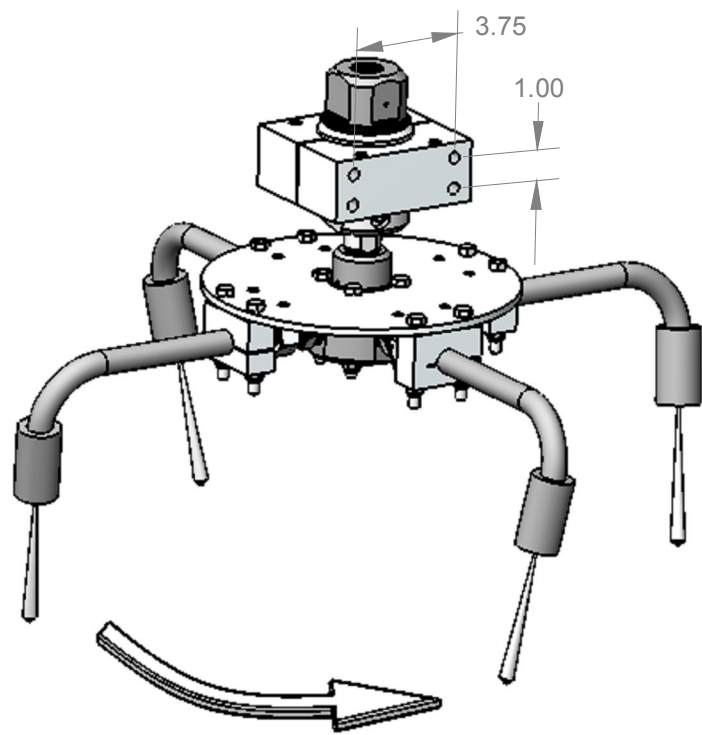

The angle of the arms controls the rotation speed and direction. Always angle the arms so that the jet torque tightens the manifold onto the swivel shaft.

