

Gopher™ 22 kpsi Self-Rotary Swivel (GO-M9)

US Pat. No. 5,909,848 and 6,059,202
European Patent 1068021

Description:

The **Gopher** is a self-rotating swivel designed for tube and pipe cleaning. It has an outside diameter of 1.62 inches (42mm). The tool can be used at operating pressures from 5,000 to 22,000 psi (345 to 1500 bar) and flow rates from 8 to 25 gpm. The tool has a 9/16 medium pressure cone and thread female inlet, and can be supplied with inlet adapter fittings for 1/2 or 3/8 npt female pipe thread. The swivel is filled with 10W-40 for lubrication; it also affects rotation speed. The swivel rotation can be slowed with a heavier oil such as 80W-90.

Two standard heads are available for the Gopher; both have 1/8 npt pipe threads. When installing nozzles, use Parker Thread Mate and Teflon tape for best results. The **Polisher Head (GO 042)** is intended for removing scale. The **Unplugging Head (GO 043)** is intended for use in plugged tubes. Stamped on the head is an R17 or R.14; this is the offset that makes the head rotate. If less flow is used than the range shown, the swivel will not rotate. If more flow is used than shown in the range, the tool will rotate too fast, damaging the bearings and using up the high pressure seal. Consult the table for the correct flow range for each head offset.

Offset	R17	R14	R08	R07
Flow (Polisher)	-	7 to 13 gpm	-	14 to 25 gpm
Flow (Unplugging)	8 to 14 gpm	-	15 to 25 gpm	-

The next step is to determine where the jets should go in the head. The thrust of the jets can be used to pull the tool thru a pipe or tube. Little or no pull is needed for cleaning vertically downward, but more pull is needed if cleaning horizontally or climbing upward. The jet sizes should be selected based on proportioning the total flow rate between the forward and backward jets to achieve the pulling force needed, but still applying enough power to the material being removed ahead of the tool.

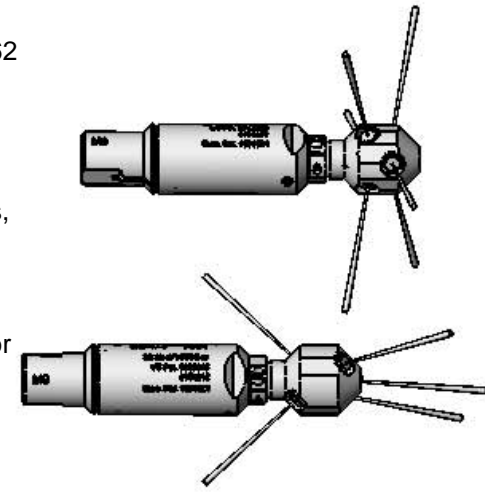

**Polisher Head
GO 042**

3 jets @ 80°
3 jets @ 100°

**Unplugging Head
GO 043**

3 Forward Ports
2 Back Ports

Operation:

Make sure there is an operator controlled dump in the system, operated by the person closest to the cleaning job. Flush out the high pressure hoses before connecting Gopher to hose end or stinger. When pipe cleaning, it is recommended that the hose be marked a few feet from the end with a piece of tape so the operator knows when to stop on the way back out. When tube cleaning, a stinger is recommended; a stinger is a rigid piece of pipe or tubing used between the end of the hose and the nozzle. It is typically 2 feet in length, and is primarily a safety device for hand flex lancing. Install tool on hose, position it in a tube or the pipe while the pressure is being set. The high pressure seal may leak initially; it should stop when pressure is increased and rotation begins. Close the dump and slowly bring up to pressure the first time, to make sure no nozzles are plugged and that the jet thrust is correct. The swivel should begin to slowly rotate. Once operating pressure is reached, feed the tool into the tube or pipe to begin the cleaning job. When using rotating nozzles in plugged tubes, the head must not be forced into the deposit, as this will stop the rotation of the tool and impede the cutting ability. When the tool contacts the deposit, allow it to cut away the material and advance at its own rate. If it stops advancing, pull back slightly on the hose to pull the head slightly away from the deposit, in case it is being stopped from rotating by the deposit. This also allows the angled jets to attack the deposit at different places. When polishing tubes with scale, it is possible to allow the nozzle to pass through the tube at incredibly fast rates; unless the deposit is very easy to remove, this will not completely remove the scale. The operator needs to be trained to feed the nozzle through the tube at a rate sufficient to clean the tube. Once the work is complete and the tool is disconnected from the hose, blow out all water to prolong the life of the tool. A small amount of oil can be blown into the inlet nut as well.

Troubleshooting:

Head will not rotate: First try rotating head by hand and see if it feels rough or gritty to turn. If it does, the tool must be disassembled and repaired. If the tool has just been repaired and the head starts to rotate but slows down and stops as pressure is increased, the front bearing (RJ 007) is installed backwards. If the tool feels okay, check to see if any nozzles are plugged; even if a nozzle is only partially blocked it can keep the head from rotating. Nozzles must be removed from the head to properly clean them. Refer to the above description about the head offset and double check the nozzle sizes to make sure they are correct for the expected flow rate.

Head spins too fast: if the swivel is low on oil, or the oil has water in it. Add a full syringe of oil; check that the shaft seals are still good and will keep the fluid from leaking out. Finally, if it is rotating extremely fast and failing high pressure seals in a few minutes, the spring that controls the speed is broken or disconnected.

Seal Leak: The seal may leak initially up to several thousand psi, but should pop closed as pressure is increased. If operating pressure is reached and the seal is leaking continuously, the high pressure seal may need to be replaced. Refer to the maintenance below. If the seal and seat are replaced and the tool still leaks, inspect the shaft end face for damage such as dents, nicks or erosion.

Seals wear out quickly: The tool must be disassembled and inspected. The carbide seat should be checked for being installed in the right direction, and it should not have any chips or erosion marks on it. The seal holder (GO 020) should be replaced if it has any groove in the bore where the seal fits.

Maintenance:

***Blow out all water with compressed air before storing tool!**

The Gopher uses 10W-40 Oil for lubrication. It is recommended that a full syringe of fresh oil be added to the swivel after every 20 to 40 hours of use. If faster rotation speed is desired, use oil with lower viscosity. If slower rotation speed is desired, use oil with higher viscosity.

To fill the Gopher with oil:

1. Fill the syringe (FT 110) with oil.
2. Remove the Port Screw (FT 026) and thread the syringe into the port.
3. Squeeze fresh oil into the swivel; excess will come out the slots.
4. Remove Syringe and install Port Screw. Make sure the Port Screw has the washer on it.

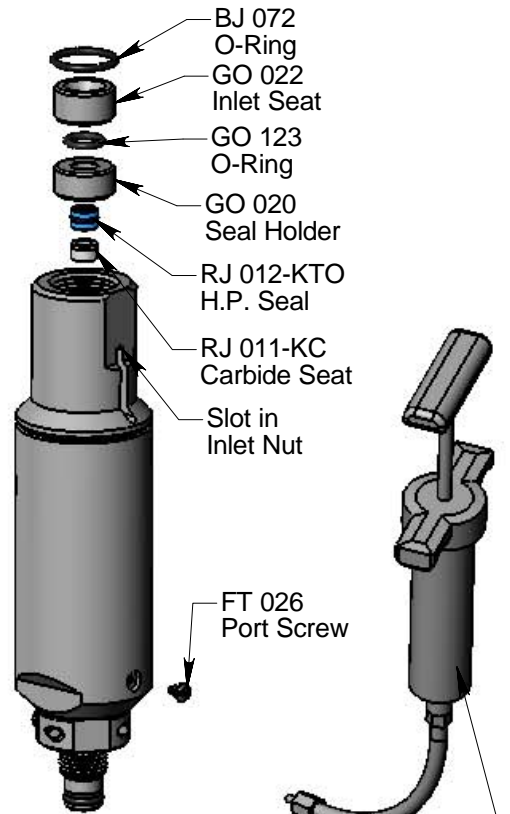

Detailed View:

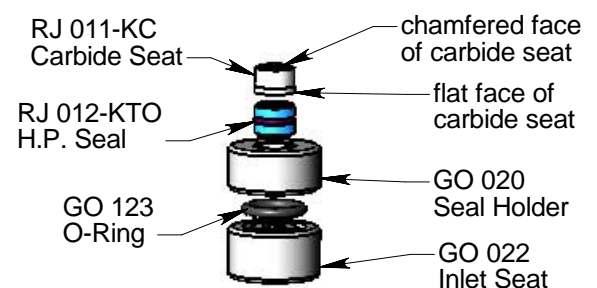

To replace the high pressure seal:

1. Remove the O-Ring (BJ 072) from groove in Inlet Nut. It is easiest to push it inward from the top of the slot.
2. Use two picks inserted thru the slots to pry the Seal Holder (GO 020) and Inlet Seat (GO 022) up and out.
3. Remove the Carbide Seat (RJ 011-KC) and H.P. Seal (RJ 012-KTO). Inspect the Seal Holder for grooves. If it is badly grooved, it can be flipped over or replaced.
4. Inspect the Carbide Seat for chips or erosion. Replace if damaged. Inspect end of shaft for dings or erosion.
5. Check that O-Ring (GO 123) is in groove of Inlet Seat. Place Seal Holder on top of Inlet Seat.
6. Apply grease to a new H.P. Seal and install in Seal Holder. Apply grease to the flat face of the Carbide Seat and install with this flat face against the H.P. Seal.
7. Balance the Inlet Seat and Seal Holder on fingertip; turn swivel upside down and slide these parts into the Inlet Nut. Make sure that the Carbide Seat stays in bore of Seal Holder.
8. Turn the swivel inlet end up; the Inlet Seat and Seal Holder should be far enough in to install the O-Ring (BJ 072) into the groove in the Inlet Nut.

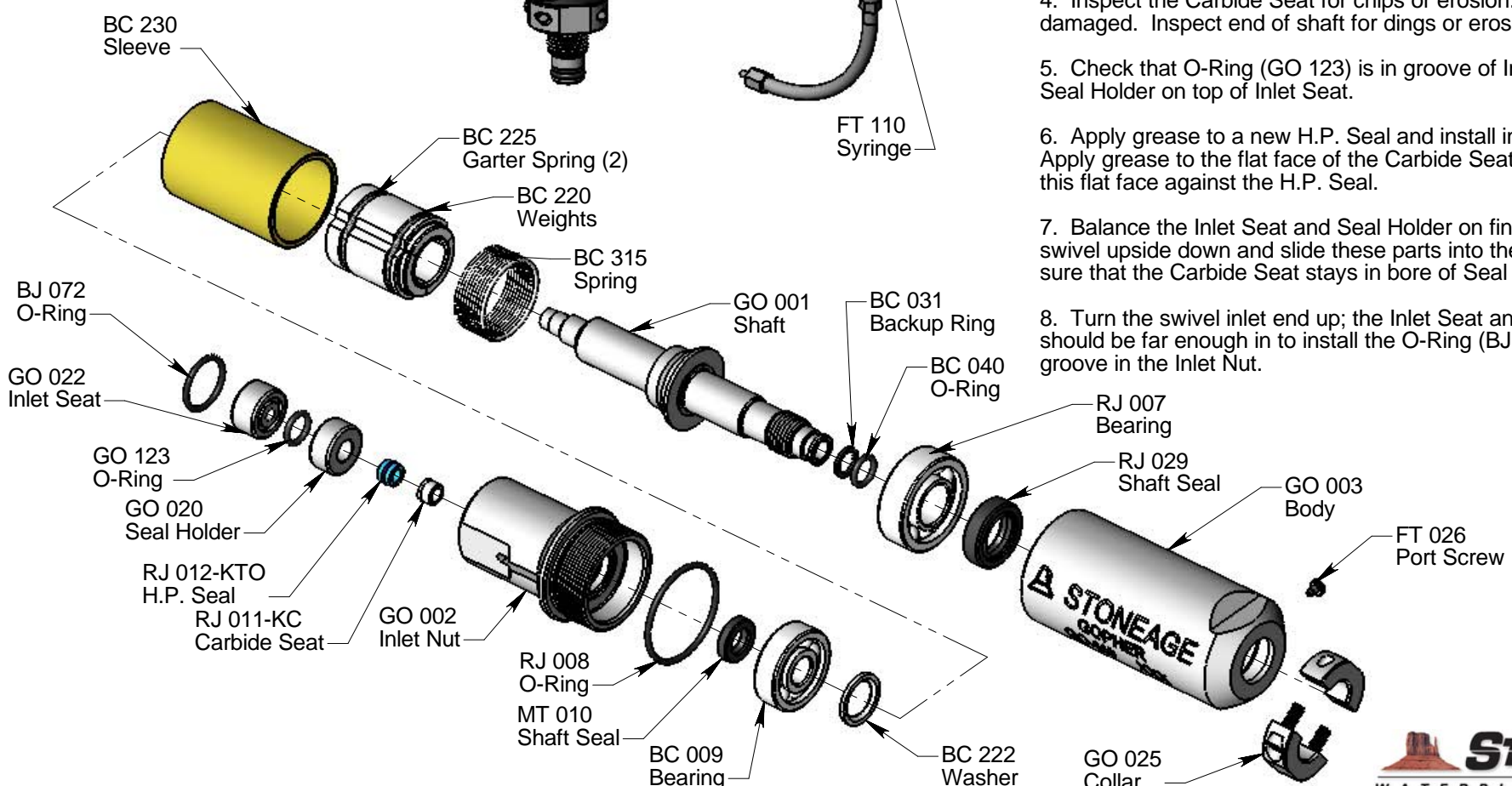

Gopher™ 22 kpsi Self-Rotary Swivel (GO-M9)

US Pat. No. 5,909,848 and 6,059,202
European Patent 1068021

Disassembly:

1. Remove O-Ring (BJ 072) from Inlet Nut. Pry out the Seal Holder (GO 020) and Inlet Seat (GO 022) as explained in the Maintenance Section.
2. Remove the Collar (GO 025) from the Shaft.
3. Unscrew the Inlet Nut (GO 002) from the Body (GO 003).
4. Push Shaft (GO 001) and all attached parts up and out of Body.
5. Slide the Sleeve (BC 230) off of the Shaft.

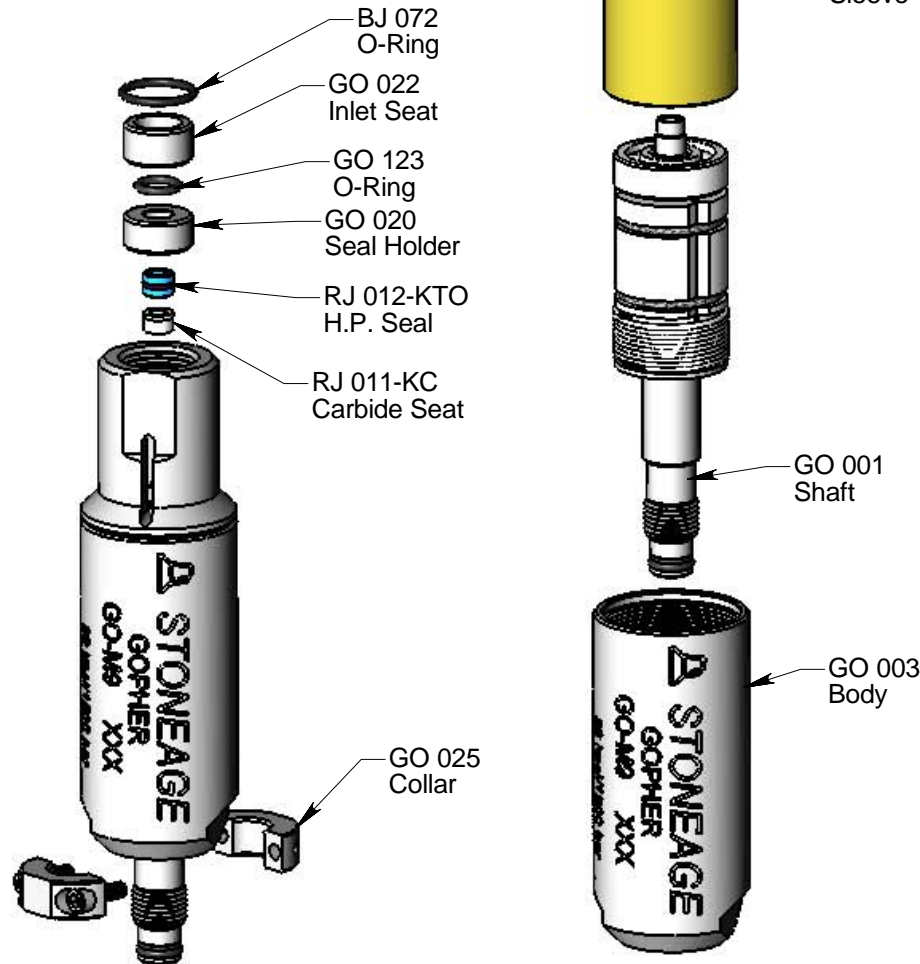

6. If the Shaft Seals (MT 010, RJ 029) in the Inlet Nut and Body appear damaged, pry them out and replace them.
7. Pull the Bearing (BC 009) off of the top of the Shaft; remove the Washer (BC 222).

8. Unhook the Spring (BC 315) from the hole in the Shaft; remove the Weights (BC 220) and Spring (BC 315) from the Shaft. Leave the Weights together.
9. Inspect the O-Ring (BC 040) and Backup Ring (BC 031) on the Shaft end. Replace them if they are cut or damaged.

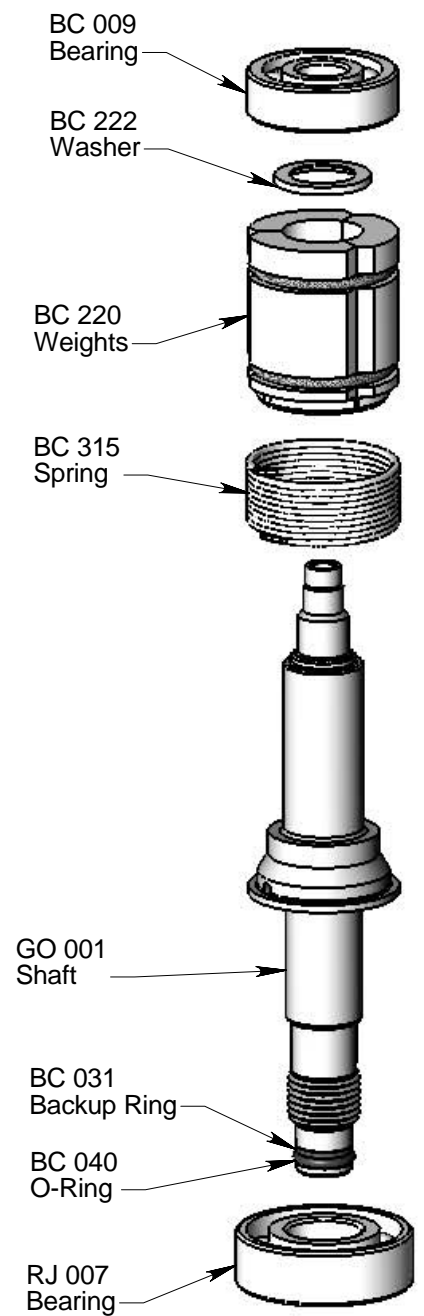

Assembly:

1. Install O-Ring (RJ 008) over the threads of the Inlet Nut (GO 002). Install Shaft Seal (MT 010) into the inlet Nut; the lip with the spring faces down in this view.
2. Install Shaft Seal (RJ 029) into Body (GO 003); the lip with the spring faces up in this view. Apply grease or Armour-All to the lips of the seals.

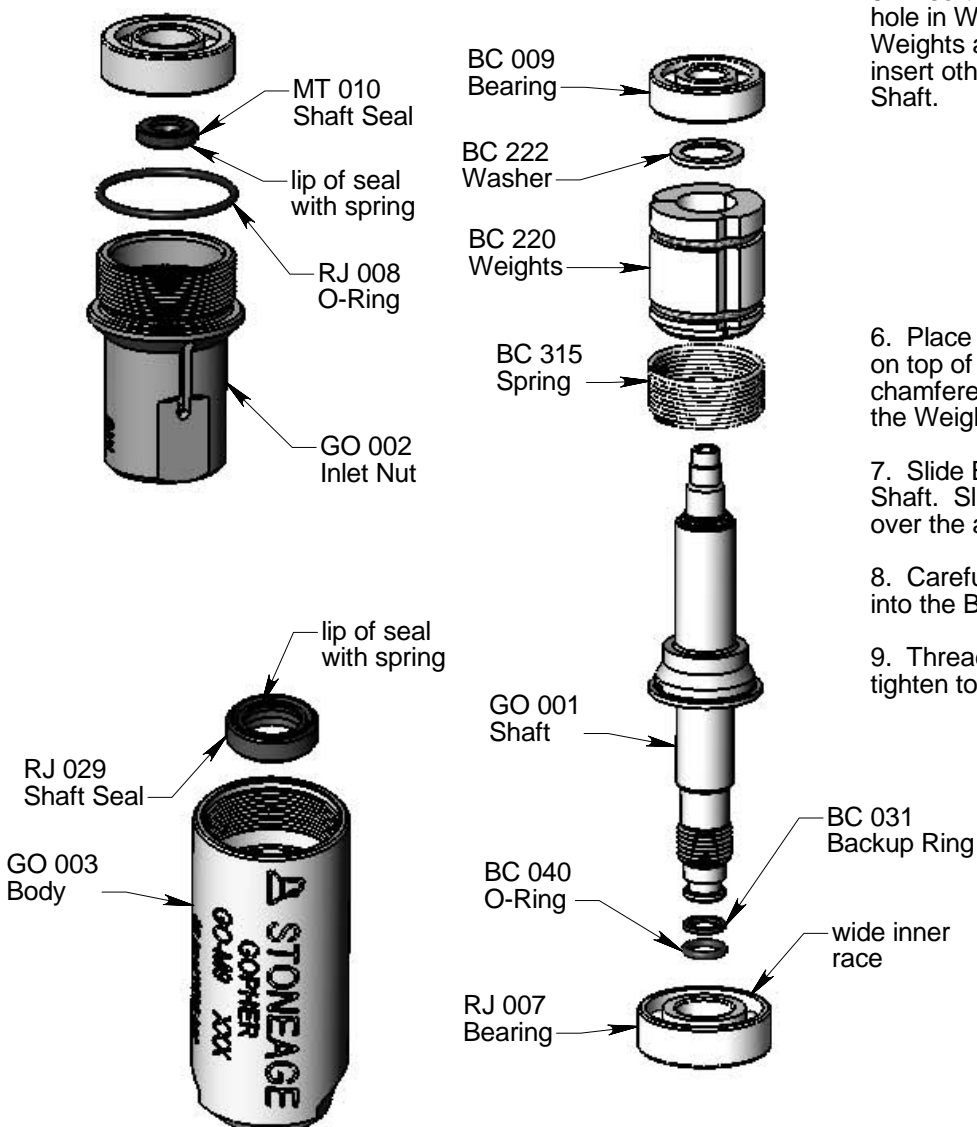

3. Install Bearing (RJ 007) on Shaft (GO 001); this is a thrust bearing and must be installed with the wide inner race facing toward shoulder on Shaft.
4. If O-Ring and Backup Ring were removed, install new ones in the correct order.
5. Insert Spring (BC 315) end into hole in Weights (BC 220), then slide Weights and Spring onto Shaft and insert other spring end into hole in Shaft.

6. Place Washer (BC 222) on top of Weights, with the chamfered side facing toward the Weights.
7. Slide Bearing (BC 009) onto Shaft. Slide Sleeve (BC 230) over the assembly.
8. Carefully insert shaft assembly into the Body.
9. Thread Inlet Nut into Body; tighten to 40 ft-lb.

10. Install the Collar (GO 025) onto the Shaft end.
11. Install the high pressure seal components as described in the Maintenance Section.
12. Fill the swivel with oil as shown in the Maintenance Section. Install the Port Screw (FT 026).

