

Gopher™ 40 kpsi Self-Rotary Swivel (GO-H9-C)

US Pat. No. 5,909,848 and 6,059,202
European Patent 1068021

Description:

The **Gopher H9-C** is a self-rotating swivel designed for tube and pipe cleaning. It has an outside diameter of 1.62 inches (42mm). The tool can be used at operating pressures up to 40,000 psi (2800 bar) and flow rates from 4 to 10 gpm. The tool has a 9/16 high pressure cone and thread female inlet, with an easily replaced seal cartridge assembly. The swivel is filled with 10W-40 for lubrication; it also affects rotation speed. The swivel rotation can be slowed with a heavier oil such as 80W-90.

Two standard heads are available for the Gopher; both have 1/4-28 threads for sapphire nozzles. When installing nozzles, use Blue Goop antiseize for best results. The **Polisher Head (GO 342)** is intended for removing scale. The **Unplugging Head (GO 343)** is intended for use in plugged tubes. Stamped on the head is an R18 or R08; this is the offset that makes the head rotate. If less flow is used than the range shown, the swivel will not rotate. If more flow is used than shown in the range, the tool will rotate too fast, damaging the bearings and using up the high pressure seal.

Consult the table for the correct flow range for each head offset.

Offset	R18	R14	R08
Flow (Polisher)	-	3.7 to 6.6 gpm	7 to 10 gpm
Flow (Unplugging)	4 to 7 gpm	-	7.1 to 10 gpm

Determine where the jets should go in the head. The thrust of the jets can be used to pull the tool through a pipe or tube. Little or no pull is needed for cleaning vertically downward, but more pull is needed if cleaning horizontally or climbing upward. The jet sizes should be selected based on proportioning the total flow rate between the forward and backward jets to achieve the pulling force needed, but still applying enough power to the material being removed ahead of the tool.

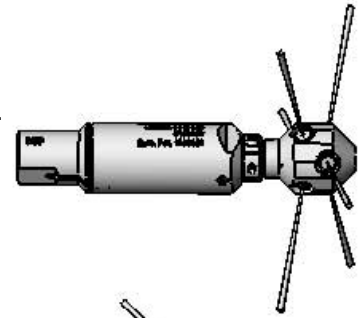

**Polisher Head
GO 342**

3 Ports at 80°
3 Ports at 100°

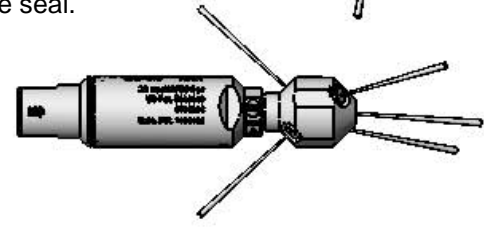

**Unplugging Head
GO 343**

3 Forward Ports
2 Back Ports

Operation:

Make sure there is an operator controlled dump in the system, operated by the person closest to the cleaning job. Flush out the high pressure hoses before connecting Gopher to hose end or stinger. When pipe cleaning, it is recommended that the hose be marked a few feet from the end with a piece of tape so the operator knows when to stop on the way back out. When tube cleaning, a stinger is recommended; a stinger is a rigid piece of pipe or tubing used between the end of the hose and the nozzle. It is typically 2 feet in length, and is primarily a safety device for hand flex lancing. Install tool on hose, position it in a tube or the pipe while the pressure is being set. The high pressure seal may leak initially; it should stop when pressure is increased and rotation begins. Close the dump and slowly bring up to pressure the first time, to make sure no nozzles are plugged and that the jet thrust is correct. The swivel should begin to slowly rotate. Once operating pressure is reached, feed the tool into the tube or pipe to begin the cleaning job. When using rotating nozzles in plugged tubes, the head must not be forced into the deposit, as this will stop the rotation of the tool and impede the cutting ability. When the tool contacts the deposit, allow it to cut away the material and advance at its own rate. If it stops advancing, pull back slightly on the hose to pull the head slightly away from the deposit, in case it is being stopped from rotating by the deposit. This also allows the angled jets to attack the deposit at different places. When polishing tubes with scale, it is possible to allow the nozzle to pass through the tube at incredibly fast rates; unless the deposit is very easy to remove, this will not completely remove the scale. The operator needs to be trained to feed the nozzle through the tube at a rate sufficient to clean the tube. Once the work is complete and the tool is disconnected from the hose, blow out all water to prolong the life of the tool. A small amount of oil can be blown into the inlet nut as well.

Troubleshooting:

Head will not rotate: First try rotating head by hand and see if it feels rough or gritty to turn. If it does, the tool must be disassembled and repaired. If the tool has just been repaired and the head starts to rotate but slows down and stops as pressure is increased, the front bearings (RJ 007) are installed backwards. If the tool feels okay, check to see if any nozzles are plugged; even if a nozzle is only partially blocked it can keep the head from rotating. Nozzles must be removed from the head to properly clean them. Refer to the above description about the head offset and double check the nozzle sizes to make sure they are correct for the expected flow rate.

Head spins too fast: if the swivel is low on oil, or the oil has water in it. Add a full syringe of oil; check that the shaft seals are still good and will keep the fluid from leaking out. Finally, if it is rotating extremely fast and failing high pressure seals in a few minutes, the spring that controls the speed is broken or disconnected.

Seal Leak: The seal may leak initially up to several thousand psi, but should pop closed as pressure is increased. If operating pressure is reached and the seal is leaking continuously, the cartridge should be replaced. Refer to the maintenance below. If the cartridge is replaced and the tool still leaks, inspect the shaft end face for damage such as dents, nicks or erosion.

Seals wear out quickly: Remove and inspect the cartridge parts. The carbide seat should be checked for chips or erosion marks on it. When the life of the high pressure seal becomes noticeably less, the seal retainer needs to be replaced. Also replace the carbide seat if it has not been replaced with each seal change.

Maintenance:

***Blow out all water with compressed air before storing tool!**

To assemble the Cartridge Assy:

- Place Mandrel (BC 414) on a flat surface.
- Stack the Inlet Seat (BC 522-001) with the internal cone at the bottom onto the Mandrel.
- Insert Compression Spring (BC 524) into bore of Inlet Seat.
- Insert H.P. Seal (BC 512-O) into bore of Inlet Seat making sure the end with the O-Ring and seal support goes in first. (see detail)
- Stack the Carbide Seat (BC 511) making sure the chamfered end is against the H.P. Seal. (see detail)
- Stack the Seal Retainer (BC 520) around the Carbide Seat.
- Stack the Seat Face (BC 506).
- Slip the Cartridge Housing (BC 407) over entire stack and pick up the whole assembly with mandrel still inserted.
- Insert O-Ring (BJ 072) into slot in Cartridge Housing to capture the components. Be sure to check that the entire O-Ring is seated properly.
- Remove the Mandrel.

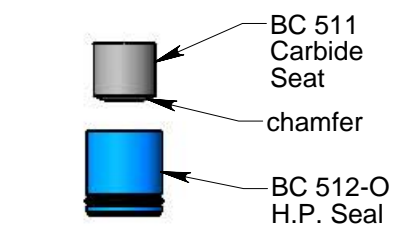

Seal & Seat Detail

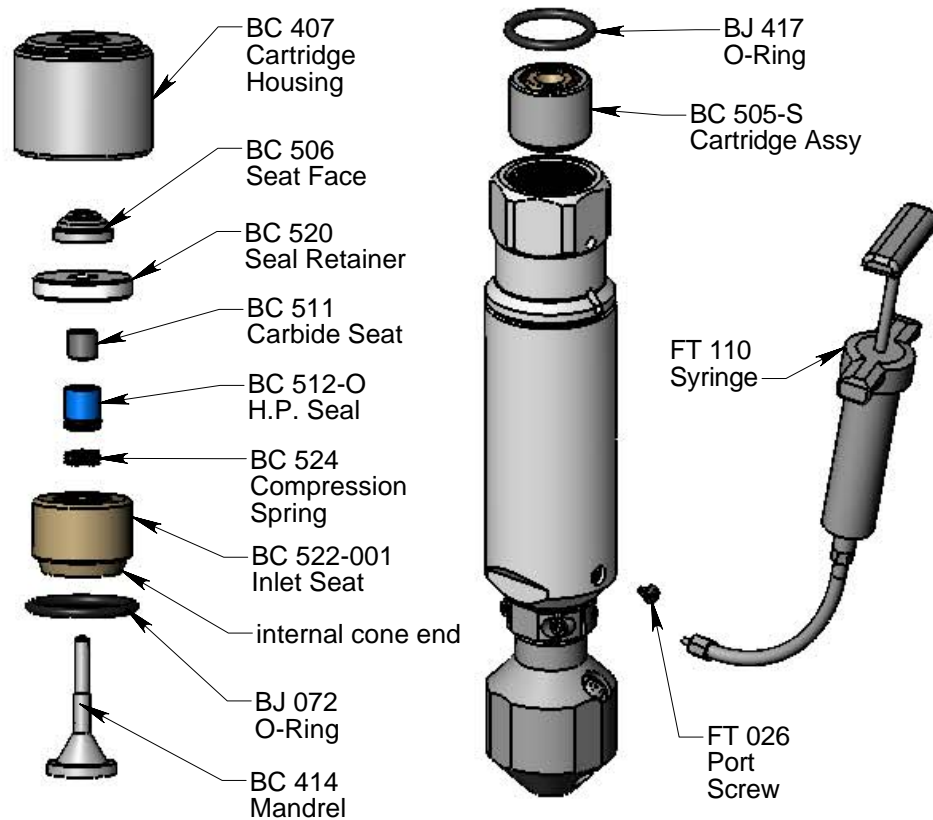

To replace the high pressure seal:

- Remove the O-Ring (BJ 417) from inlet port. It is easiest to push it upward from the round weep hole.
- If necessary, use two picks inserted thru the slots to pry the Cartridge Assy (BC 505-S) up and out of the Body.
- Turn the swivel inlet end up; insert a fresh Cartridge Assy into the inlet port and re-insert the O-ring behind the Cartridge Assy to secure it in place.

The GO-H9-C uses 10W-40 oil for lubrication and speed control. It is recommended that a full syringe of fresh fluid be added to the swivel after every 20 to 40 hours of operation.

- Remove the Port Screw (BJ 026)
- Thread the Syringe (BC 410) into the port.
- Squeeze fresh oil into the swivel; excess will come out the slots.
- Remove Syringe and install Port Screw.

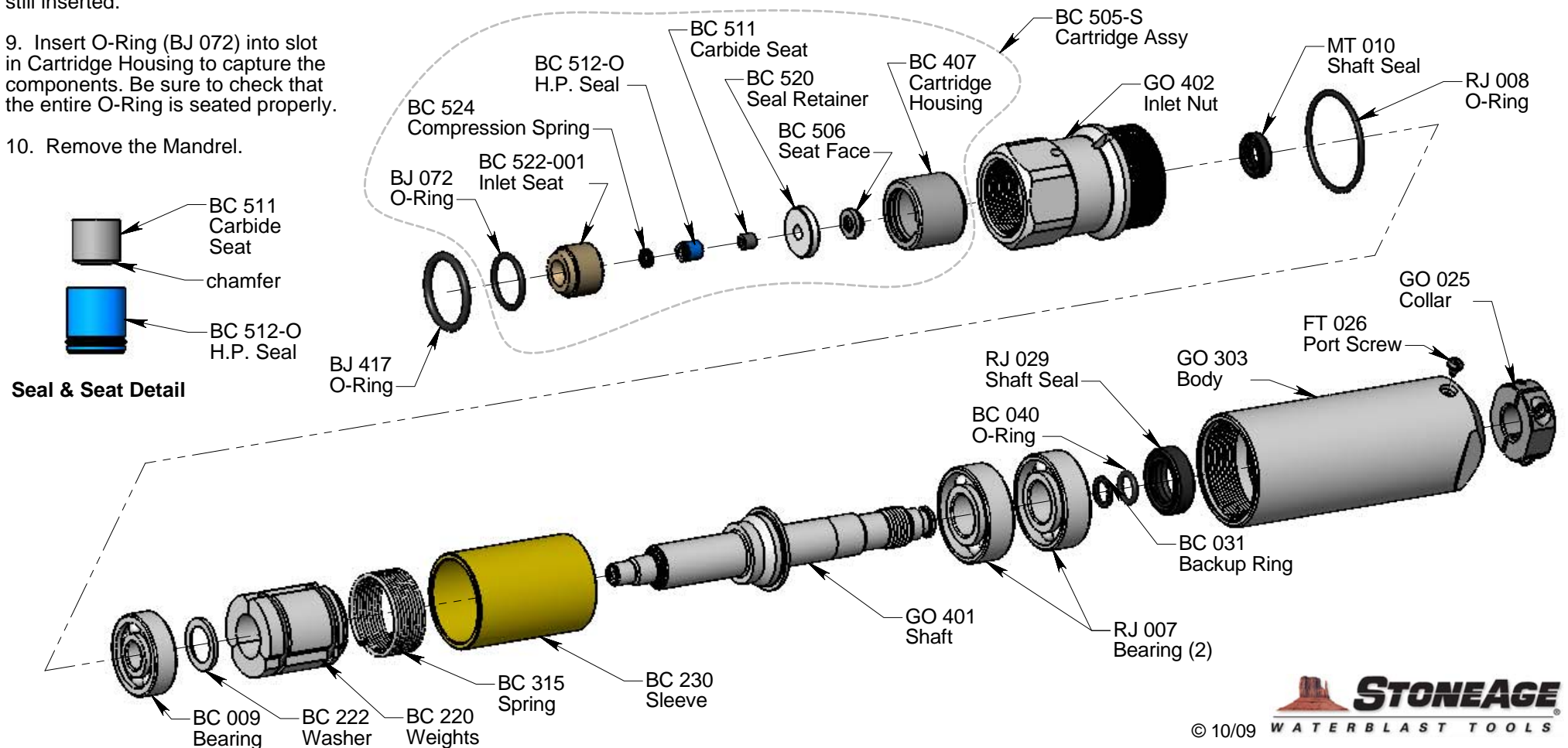

Disassembly:

1. Remove O-Ring (BJ 417) from Inlet Nut. Pry out the high pressure seal Cartridge Assy (BC 505-S) as explained in the Maintenance Section.
2. Remove the Head (not shown) and the Collar (GO 025) from the Shaft.

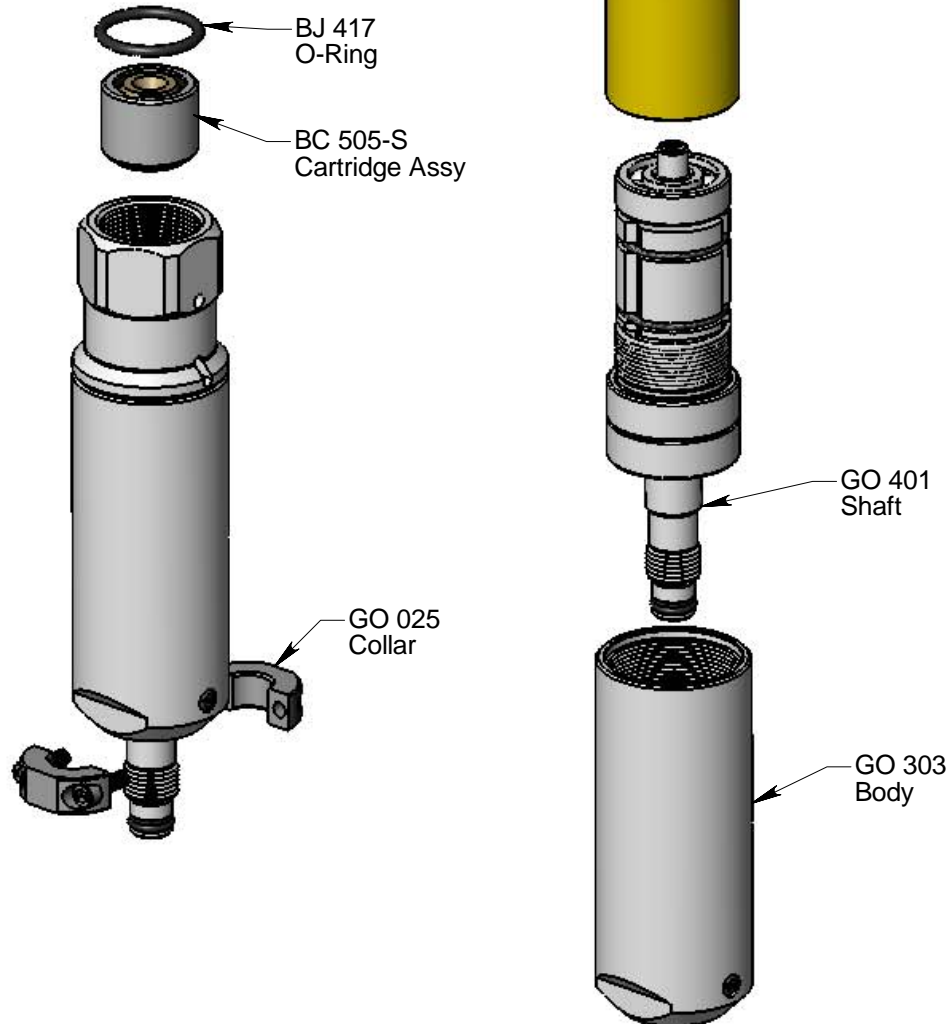

3. Unscrew the Inlet Nut (GO 402) from the Body (GO 303).
4. Push Shaft (GO 401) and all attached parts up and out of the Body.
5. Slide the Sleeve (BC 230) up and off of the shaft.
6. If the Shaft Seals (MT 010, RJ 029) in the Inlet Nut and Body are damaged, pry them out and replace them.

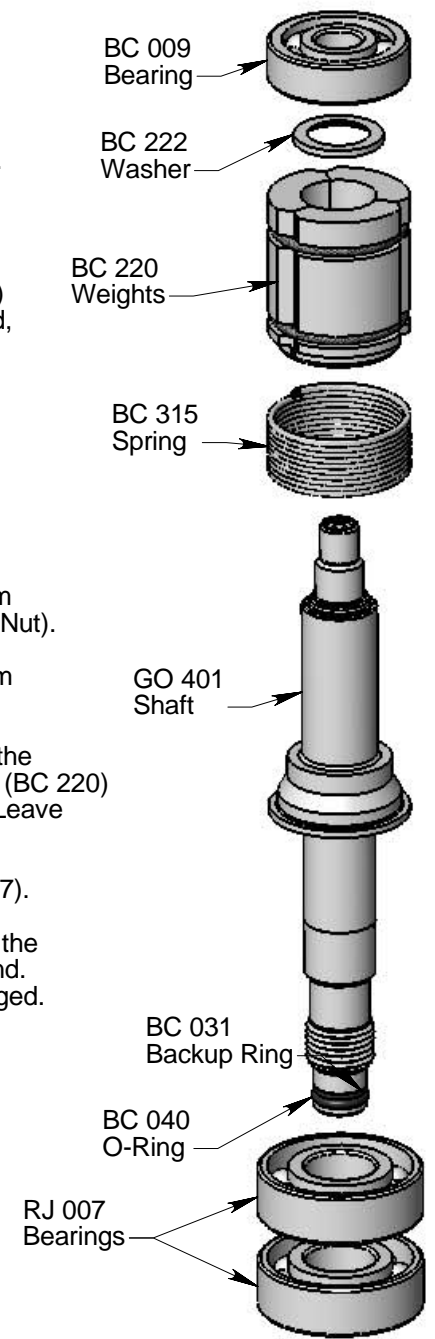

7. Remove the Bearing (BC 009) from the end of the Shaft (or from the Inlet Nut).
8. Remove the Washer (BC 222) from the shaft.
9. Unhook the Spring (BC 315) from the hole in the shaft; remove the Weights (BC 220) and Spring (BC 315) from the shaft. Leave the weights together.
10. Remove the two Bearings (RJ 007).
11. Inspect the O-Ring (BC 040) and the Backup Ring (BC 031) on the shaft end. Replace them if they are cut or damaged.

Assembly:

1. Install O-Ring (RJ 008) over the threads of the Inlet Nut (GO 402). Install Shaft Seal (MT 010) into the Inlet Nut; the lip with the spring faces down in this view.
2. Install Shaft Seal (RJ 029) into Body (GO 303); the lip of the seal with the spring faces up in this view. Apply Armour All or grease to the lips of the seals.

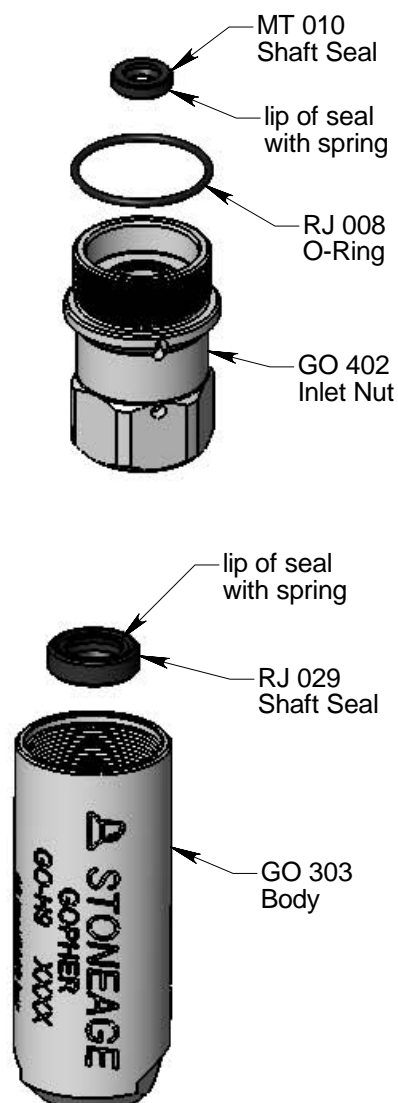

3. Install Bearings (RJ 007) on Shaft (GO 401); these are thrust bearings and must be installed with the wide inner races facing toward shoulder on shaft.
4. Install Backup Ring (BC 031) and O-Ring (BC 040) on shaft end.
5. Insert end of Spring (BC 315) into hole in Weights (BC 220), then slide weights and spring onto shaft and insert other spring end into hole in shaft.
6. Place Washer (BC 222) on top of weights with the chamfered side facing toward the weights.
7. Slide Bearing (BC 009) onto shaft. Slide Sleeve (BC 230) over the assembly.
8. Carefully insert shaft assembly into the Body (GO 303).
9. Thread Inlet Nut into Body; tighten to 40 ft-lb.

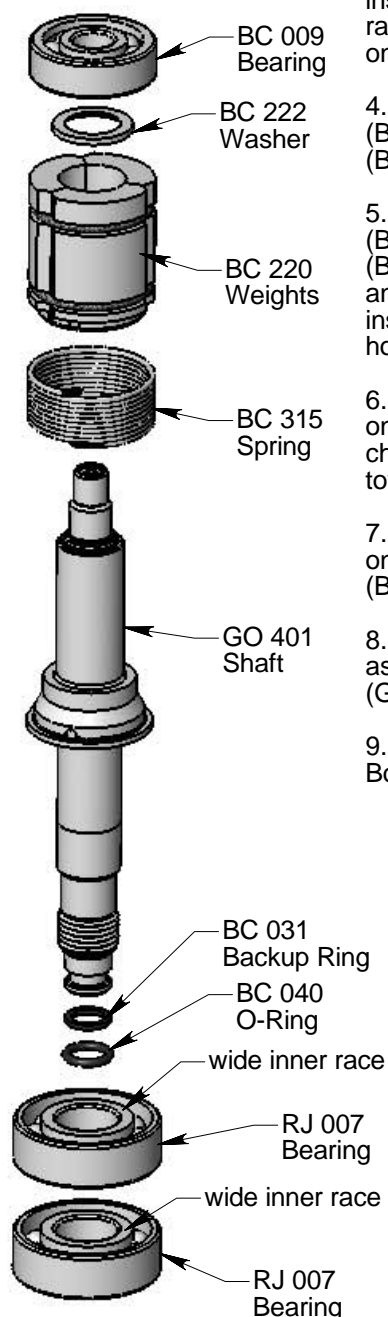

10. Install Collar (GO 025) onto end of shaft.
11. Install the high pressure seal Cartridge Assy as described in the Maintenance Section.
12. Fill the swivel with oil as shown in the Maintenance Section. Install the Port Screw (FT 026).

