

BJV-M24 Self-Rotary Swivel (22 kpsi/1500 bar)

Description:

The BJV-M24 has a M24x1.5 female inlet connection. It is capable of working pressures up to 22000 psi (1500 bar) and flow rates of 12 to 100 gpm. Speed is controlled by a viscous fluid; a thick fluid (BJ 048-S) is used for speeds of 10 to 80 rpm, and a thinner fluid (BJ 048-F) is used for speeds of 50 to 200 rpm. The fluid in the swivel can be changed to provide either fast or slow rotation.



Stamped or engraved on the BJ nozzle head is an R followed by a number, such as R12 or R.35. This number is the offset of the head that makes it rotate. This number must match the flow range given in the table below. If your flow is 25 gpm, you should have a head with R35 on it. If it has an R20 or R12 on it, the tool will not rotate, because not enough rotating force (torque) will be produced. If the head is an R60, the tool will spin too fast and wear out quicker.

The next step is to determine where the jets should go in the head. Remember that using more jets will mean they must be smaller and not hit as hard. The thrust of the jets can be used to pull the tool thru the pipe. If no pull is needed, as few as two jets can be used, just in the 90 degree ports. If jet pull is needed, use two jets in the back ports, as big as they need to be to produce the pull needed, then put jets in other ports for effective cleaning. There is also a pulling ring (HC 097) available that attaches to the head, so a cable can be used to pull the tool so no back jets are used. When installing nozzles into the head, we recommend using Parker Thread Mate and Teflon Tape. Also use these if installing the head onto the swivel shaft.

Offset	R60	R35	R20	R12
Flow	12 - 20 gpm	23 - 35 gpm	40 - 60 gpm	70 - 100 gpm

Operation:

Make sure there is an operator controlled dump in the system, operated by the person closest to the cleaning job. Flush out the high pressure hoses before connecting BJV to hose end. It is recommended that the hose be marked a few feet from the end with a piece of tape so the operator knows when to stop on the way back out. Once the BJV is attached to the hose end, position it in the pipe or vessel to be cleaned. The high pressure seal may leak initially; it should stop when pressure is increased and rotation begins. Close the dump and slowly bring up to pressure the first time, to make sure no nozzles are plugged and that the jet thrust is correct. The swivel should begin to slowly rotate. Once operating pressure is reached, feed the tool into the pipe to begin the cleaning job. Allow the jets time to do their work by feeding the hose out at a controlled rate. Once the work is complete and the tool is disconnected from the hose, blow out all water to prolong the life of the tool. A small amount of oil can be blown into the inlet nut as well.

Troubleshooting:

Head will not rotate: First try rotating head by hand and see if it feels rough or gritty to turn. If it does, the tool must be disassembled and repaired. If the head starts to rotate but as pressure is increased it slows down and stops, it likely has bad bearings. If the tool feels okay, check to see if any nozzles are plugged; even if a nozzle is only partially blocked it can keep the head from rotating. Nozzles must be removed from the head to properly clean them; it does not do any good to poke the material plugging the nozzle back into the head, as it will just replug a nozzle. If none of these are the problem, the jets are too small or the head offset is not correct; refer to the above description about the head offset and double check the nozzle sizes to make sure they are correct for the expected flow rate.

Head spins too fast: Check the nozzle sizes and head offset to make sure they are correct; refer to the description section above. If these are correct, it is likely that the swivel is low on viscous fluid, or the viscous fluid has water in it. The best thing to do is drain all the fluid, wipe the parts clean and refill with the proper fluid. Check that the shaft seals are still good and will keep the fluid from leaking out.

Seal Leak: The seal may initially leak at low pressure, but should pop closed as pressure is increased. If operating pressure is reached and the seal is leaking continuously, the high pressure seal may need to be replaced. Refer to the maintenance below.

Seals wear out quickly: The tool must be disassembled and inspected. The carbide seat should be checked for being installed in the right direction, and it should not have any chips or erosion marks on it. The bore of the shaft where the high pressure seal is located should be checked for grooving. If it is worn larger than .633", the shaft will need to be replaced.

Maintenance:

The high pressure seal will need to be replaced when water is leaking continuously out of the weep ports (under the Weep Seal) at or near operating pressure. The viscous fluid should also be checked and filled or replaced during seal maintenance.

1. Remove the Port Screw (BJ 026).
2. Hold Body by flats; unscrew the Inlet Nut (BJ 002-M).
3. Remove the Seat (MJ 011-C) and H.P. Seal (HC 012-TO) from the bore of the Shaft.
4. Inspect the Seat for chips on the edges and erosion pits on the face. Replace if damaged.
5. Inspect the face of the Inlet Nut where the Seat makes contact for dings, dents or erosion; these must be faced off to stop all leaking.
6. Check the viscous fluid level and condition; if the fluid appears badly contaminated it should be replaced. Otherwise, add fluid to cover the wave springs.

***Blow out all water with compressed air before storing tool!**

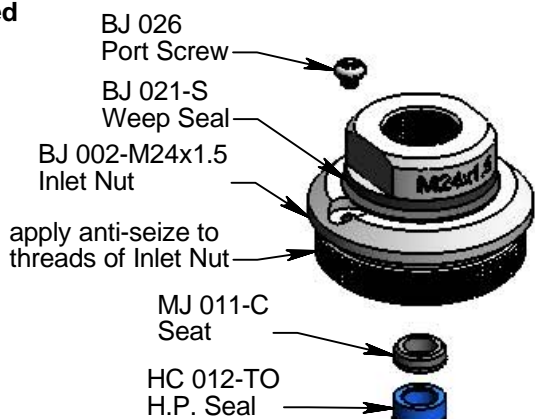

7. Apply grease to a new H.P. Seal and install into bore of shaft. Do not push it all the way in.
8. Install the Seat with the flat side against the Seal (see **detail drawing**). Push it in just far enough that it will stay in the bore.
9. Apply anti-seize to the threads of the Inlet nut; thread into Body, checking that the Seat stays centered in bore of shaft. Tighten to 60 ft-lb.
10. Install the Port Screw.

Detailed View:

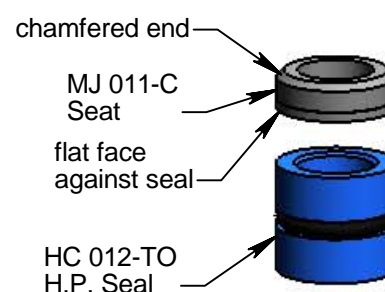

Viscous fluid level should cover the wave springs. Replace fluid if it has water or other contamination.

Never clamp or strike the round portion of Body

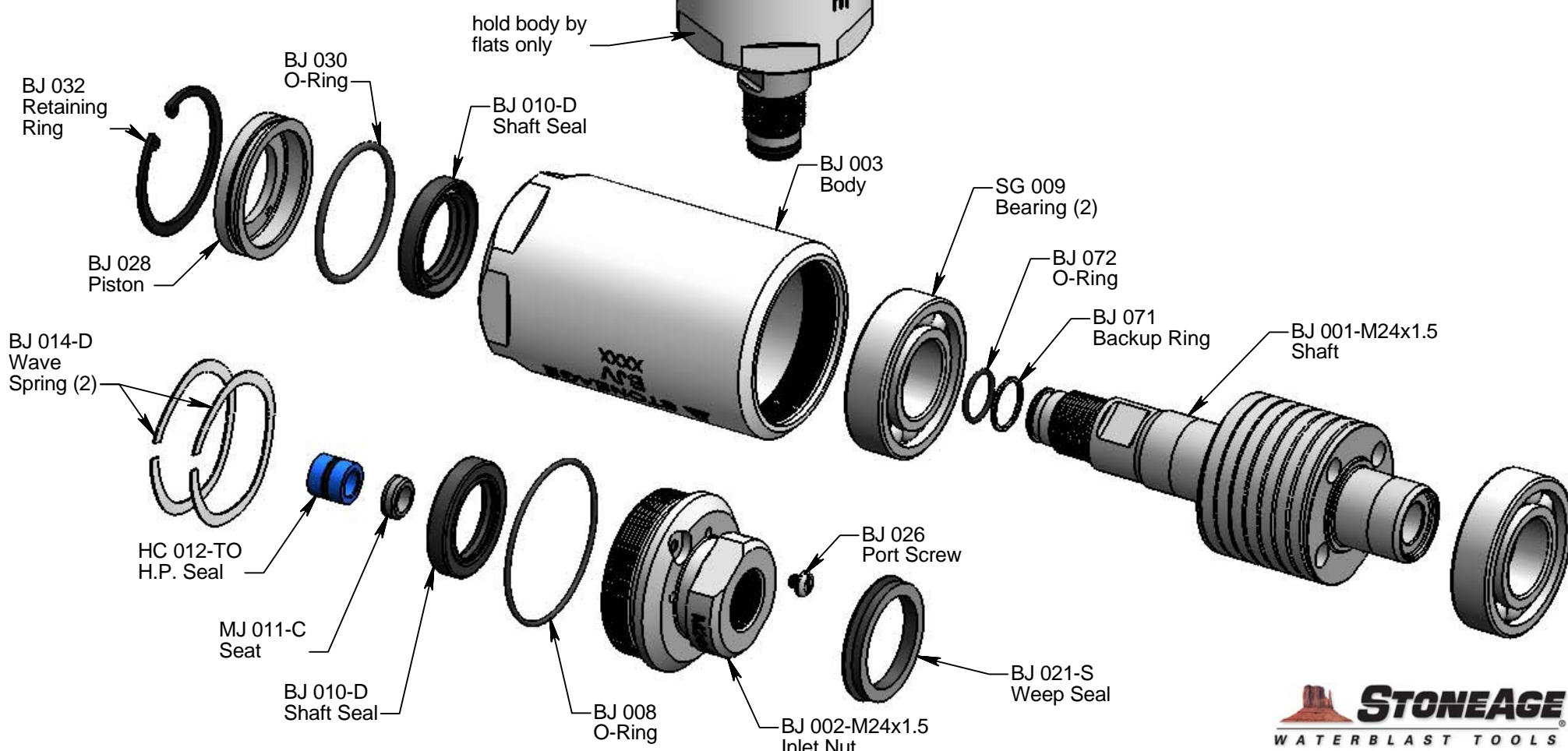

BJV-M24 Self-Rotary Swivel (22 kpsi/1500 bar)

Disassembly:

1. Remove the Port Screw (BJ 026) from the Inlet Nut (BJ 002-M24x1.5); unscrew the Inlet Nut from the Body (BJ 003).
2. Remove the Seat (MJ 011-C) and H.P. Seal (HC 012-TO) from the bore of the Shaft.
3. Remove the Wave Springs (BJ 014-D).
4. Push the Shaft (BJ 001-M24x1.5) with bearings out of the Body.
5. Carefully remove the Bearings (SG 009) from the Shaft.

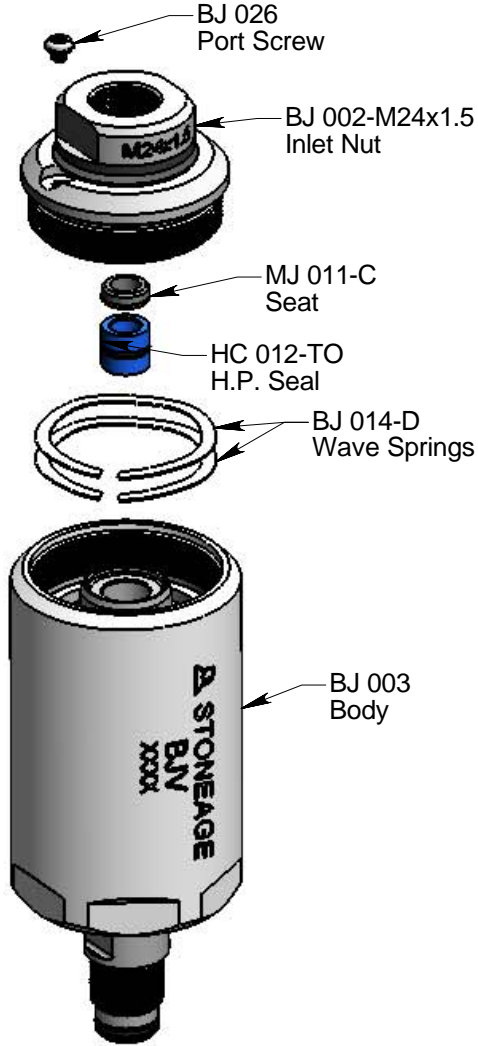

6. Remove the Retaining Ring (BJ 032) from the Body. Push out the Piston (BJ 028).
7. Inspect the O-Ring (BJ 030) and the Shaft Seal (BJ 010-D); replace if damaged.
8. Inspect the O-Ring (BJ 008), Shaft Seal (BJ 010-D) and Weep Seal (BJ 021-S) on the Inlet Nut; replace if damaged.
9. Remove the O-Ring (BJ 072) and Backup Ring (BJ 071) from Shaft.

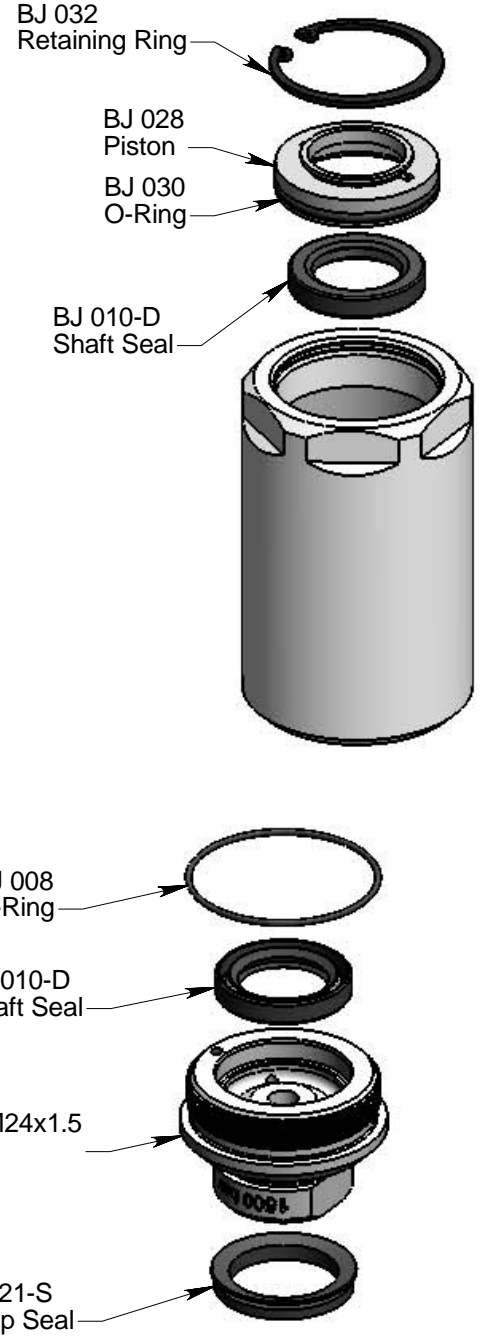
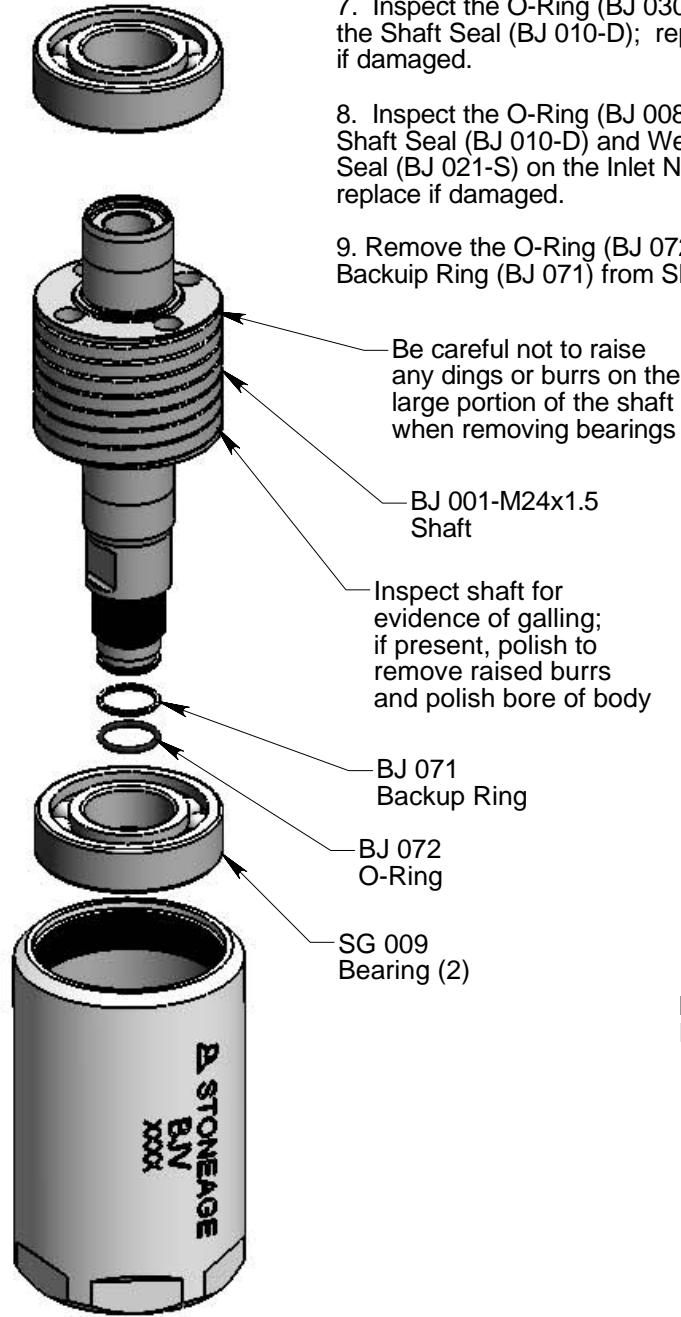

Assembly:

1. Install Shaft Seal (BJ 010-D) in Inlet Nut (BJ 002-M24x1.5) as shown.
2. Place O-Ring (BJ 008) over threads of Inlet Nut.
3. Install Weep Seal (BJ 021-S).

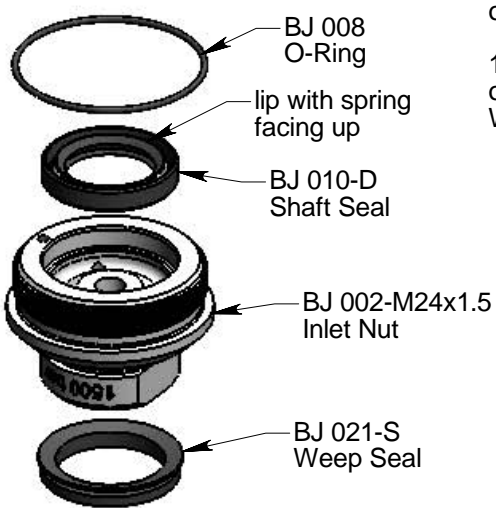

7. Press Bearings (SG 009) onto Shaft (BJ 001-M24x1.5).
8. Insert Fill Tube (HC 064) thru shaft seal in Piston up to shoulder.
9. Pour viscous fluid into Body, until about 3/4" deep.
10. Slide Shaft into Body, allowing Shaft to push out the fill tube. Fluid should come up around shaft.
11. Place the two Wave Springs (BJ 014-D) on top of bearing. Add viscous fluid until the Wave Springs are covered.

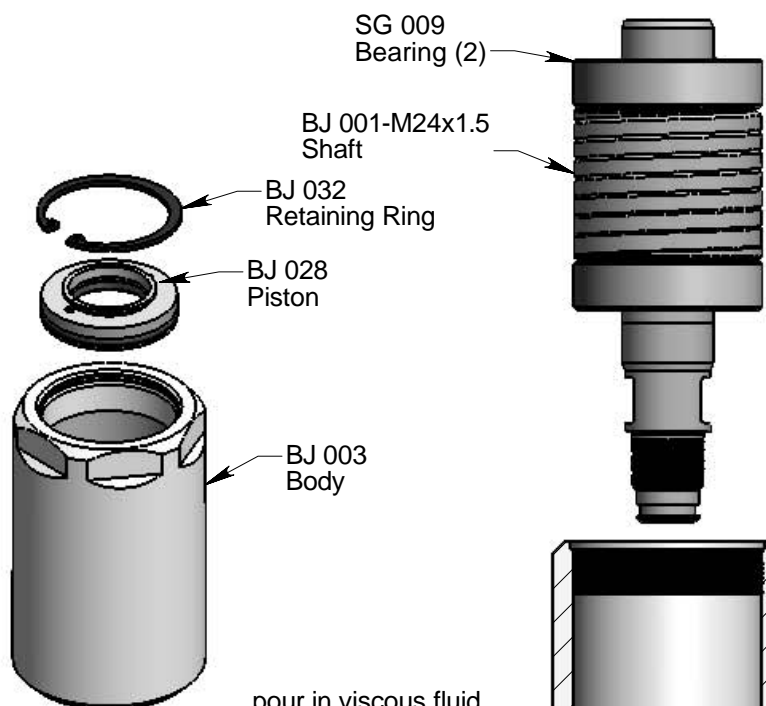

12. Apply grease to the H.P. Seal (HC 012-TO) and install in bore of shaft. Install Seat (MJ 011-C) on top of Seal, as shown in the Maintenance Section.
13. Apply anti-seize to threads of Inlet Nut and thread into Body. Tighten to 60 ft-lb.
14. Install Port Screw (BJ 026).
15. Install Backup Ring (BJ 071) and O-Ring (BJ 072) on Shaft; the O-Ring should be nearest the end of the Shaft.

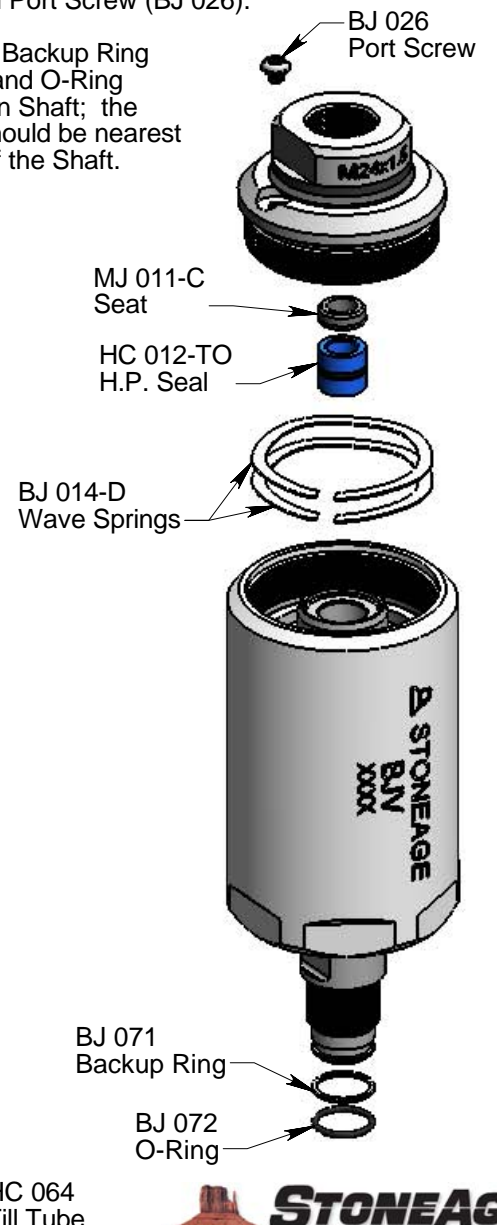

4. Install Shaft Seal (BJ 010-D) in Piston (BJ 028) as shown.
5. Place O-Ring (BJ 030) in groove around Piston.
6. Push Piston into Body (BJ 003), install Retaining Ring (BJ 032).

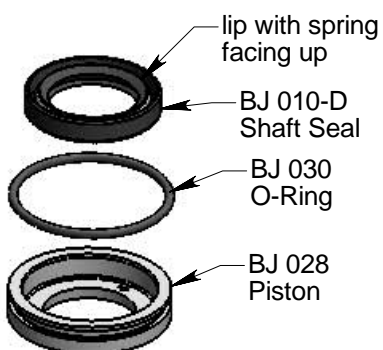

pour in viscous fluid, about 3/4" deep

