

BJV-H9 Self-Rotary Swivel (40 kpsi)

US Patent No. 6,059,202

Description:

The BJV-H9 has a 9/16 high pressure female inlet connection. It is capable of working pressures up to 40,000 psi (2800 bar) and flow rates of 3.5 to 20 gpm. Speed is controlled by a viscous fluid; a thick fluid (BJ 048-S) is used for speeds of 10 to 80 rpm, and a thinner fluid (BJ 048-F) is used for speeds of 50 to 200 rpm. The fluid in the swivel can be changed to provide either fast or slow rotation. The heads have either 3/8-24 nozzle ports or a special port to receive an extension nipple with O-ring, shown at right.

Stamped or engraved on the BJ nozzle head is an R followed by a number, such as R70 or R.40. This number is the offset of the head that makes it rotate. This number must match the flow range given in the table below. If your flow is 8 gpm, you should have a head with R40 on it. If it has an R25 on it, the tool will not rotate, because not enough rotating force (torque) will be produced. If the head is an R70, the tool will spin too fast and wear out quicker.

The next step is to determine where the jets should go in the head. Remember that using more jets will mean they must be smaller and not hit as hard. The thrust of the jets can be used to pull the tool thru the pipe. If no pull is needed, as few as two jets can be used, just in the 90 degree ports. If jet pull is needed, use two jets in the back ports, as big as they need to be to produce the pull needed, then put jets in other ports for effective cleaning. There is also a pulling ring (HC 097) available that attaches to the head, so a cable can be used to pull the tool so no back jets are used. When installing nozzles into the head, we recommend using Blue Goop. Also use this if installing the head onto the swivel shaft.

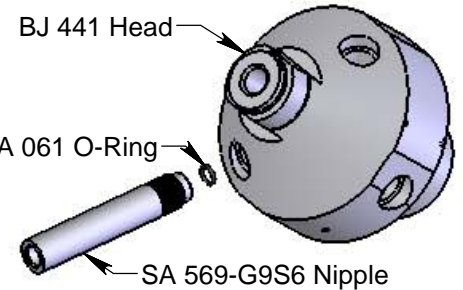

Offset	R70	R40	R25
30kpsi	3.9 - 6.7 gpm	6.7 - 11.9 gpm	10.9 - 20 gpm
35kpsi	3.6 - 6.2 gpm	6.4 - 11.0 gpm	10.0 - 18.0 gpm
40kpsi	3.4 - 5.8 gpm	5.8 - 10.2 gpm	9.3 - 11.6 gpm

Operation:

Make sure there is an operator controlled dump in the system, operated by the person closest to the cleaning job. Flush out the high pressure hoses before connecting BJV to hose end. It is recommended that the hose be marked a few feet from the end with a piece of tape so the operator knows when to stop on the way back out. Once the BJV is attached to the hose end, position it in the pipe or vessel to be cleaned. The high pressure seal may leak initially; it should stop when pressure is increased and rotation begins. Close the dump and slowly bring up to pressure the first time, to make sure no nozzles are plugged and that the jet thrust is correct. The swivel should begin to slowly rotate. Once operating pressure is reached, feed the tool into the pipe to begin the cleaning job. Allow the jets time to do their work by feeding the hose out at a controlled rate. Once the work is complete and the tool is disconnected from the hose, blow out all water to prolong the life of the tool. A small amount of oil can be blown into the inlet nut as well.

Troubleshooting:

Head will not rotate: First try rotating head by hand and see if it feels rough or gritty to turn. If it does, the tool must be disassembled and repaired. If the head starts to rotate but as pressure is increased it slows down and stops, it likely has bad bearings. If the tool feels okay, check to see if any nozzles are plugged; even if a nozzle is only partially blocked it can keep the head from rotating. Nozzles must be removed from the head to properly clean them; it does not do any good to poke the material plugging the nozzle back into the head, as it will just replug a nozzle. If none of these are the problem, the jets are too small or the head offset is not correct; refer to the above description about the head offset and double check the nozzle sizes to make sure they are correct for the expected flow rate.

Head spins too fast: Check the nozzle sizes and head offset to make sure they are correct; refer to the description section above. If these are correct, it is likely that the swivel is low on viscous fluid, or the viscous fluid has water in it. The best thing to do is drain all the fluid, wipe the parts clean and refill with the proper fluid. Check that the shaft seals are still good and will keep the fluid from leaking out.

Seal Leak: The seal may initially leak at low pressures, but should pop closed as pressure is increased. If operating pressure is reached and the seal is leaking continuously, the high pressure seal may need to be replaced. Refer to the maintenance below.

Seals wear out quickly: The tool must be disassembled and inspected. The carbide seat should be checked for being installed in the right direction, and it should not have any chips or erosion marks on it. Inspect the Seal Holder (BJ 420) and replace it if it has a groove in the inside bore.

Maintenance:

Keeping the tool full of viscous fluid is the most important maintenance procedure for long tool life. It should be done when the tool begins to rotate faster than usual; this can occur between 50 and 100 hours.

1. Hold swivel upright as shown. Remove the Port Screws (BJ 026) from the Inlet Nut and the Body.

2. Fill the Syringe (BC 410) by unscrewing the handle and pouring the correct viscosity viscous fluid in from the back end.

3. Thread Syringe into port in Body; squeeze fluid into swivel. Repeat until clean fluid comes out port in Inlet Nut. Remove Syringe and install Port Screws.

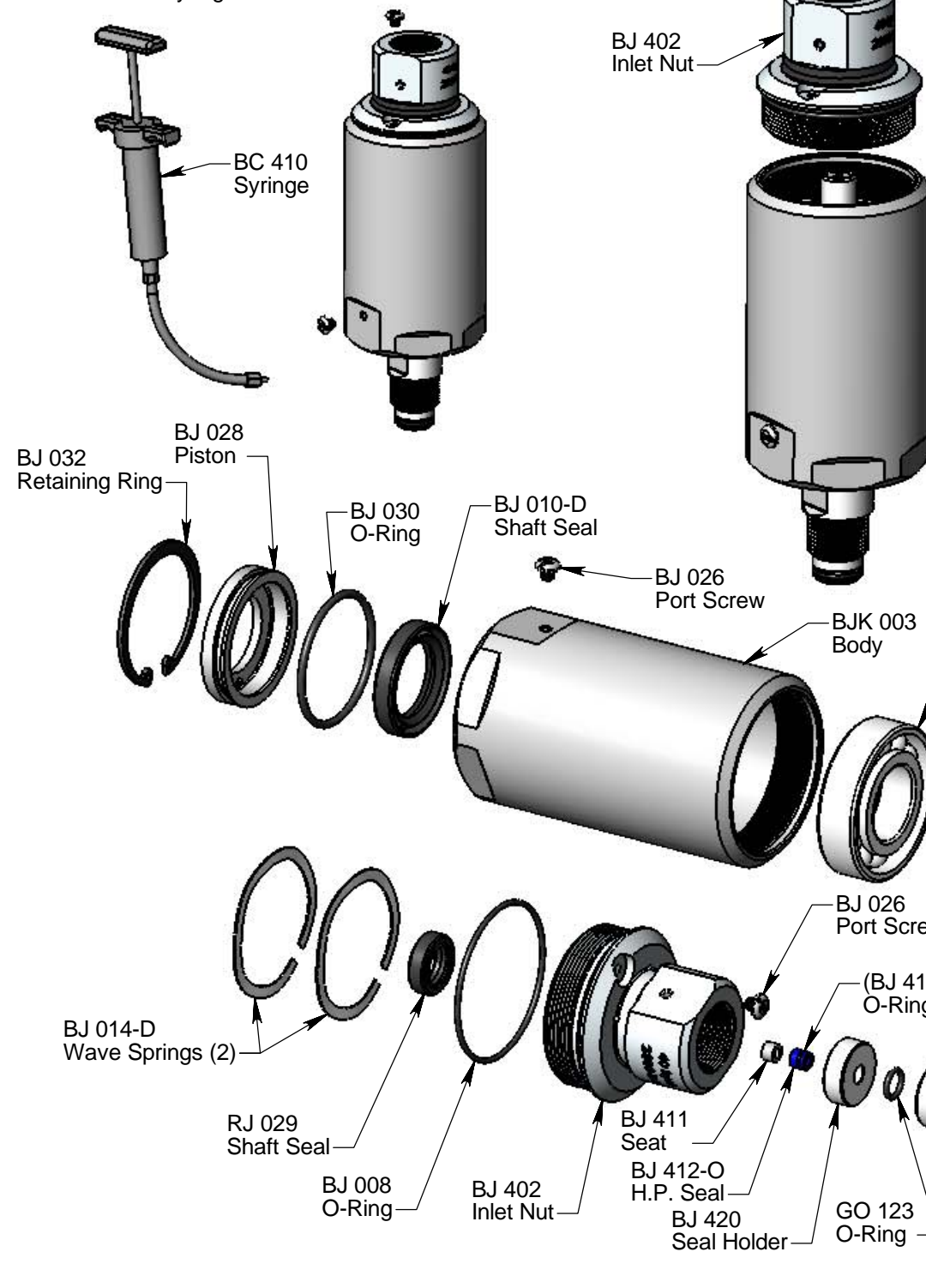

Detailed View:

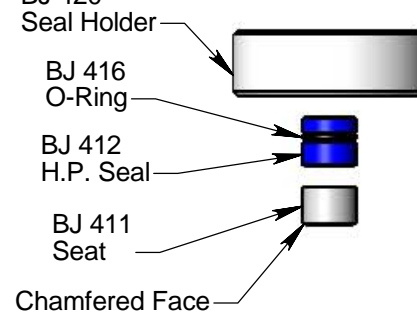

To replace the High Pressure Seal:

1. Remove the Port Screw (BJ 026) in the Inlet Nut. Unscrew the Inlet Nut (BJ 402) from the Body.
2. Remove the O-Ring (BJ 417) from the rear of the Inlet Nut.
3. Push out the Seal Holder (BJ 420), with Seat (BJ 411), H.P. Seal (BJ 412-O) and the Inlet Seat (BJ 422).
4. Inspect the Seat (BJ 411) for chips or erosion pits. Inspect the face of the Shaft where the Seat makes contact for dings, dents, or erosion.
5. Apply anti-seize to the threads of the Inlet Nut (BJ 402) and thread into Body. Tighten to 50 ft-lb and install the Port Screw (BJ 026).
6. Apply grease to new H.P. Seal and install in Seal Holder (BJ 420). The end with the O-Ring (BJ 416) goes in first, away from the Seat. Apply grease to the flat face of the Seat (BJ 411) and stick this side to the H.P. Seal, as shown in detail above.
7. Place this assembly onto the Inlet Seat (BJ 422) and slide all of these parts into the Inlet Nut. They should go in far enough to allow placing of the O-Ring (BJ 417) in the groove behind them.

Available Maintenance Kits:

- BJ 600-H9-x Service Kit (Includes items needed for maintenance)
- BJ 602-H9 Seal Kit (Includes parts needed for one seal change)
- BJ 610-H9-x Overhaul Kit (Includes parts needed for tool rebuild)
- BJ 612-H9 Tool Kit (Includes tools to aid assembly)

BJV-H9 Self-Rotary Swivel (40 kpsi)

Pat. 6,059,202

Disassembly:

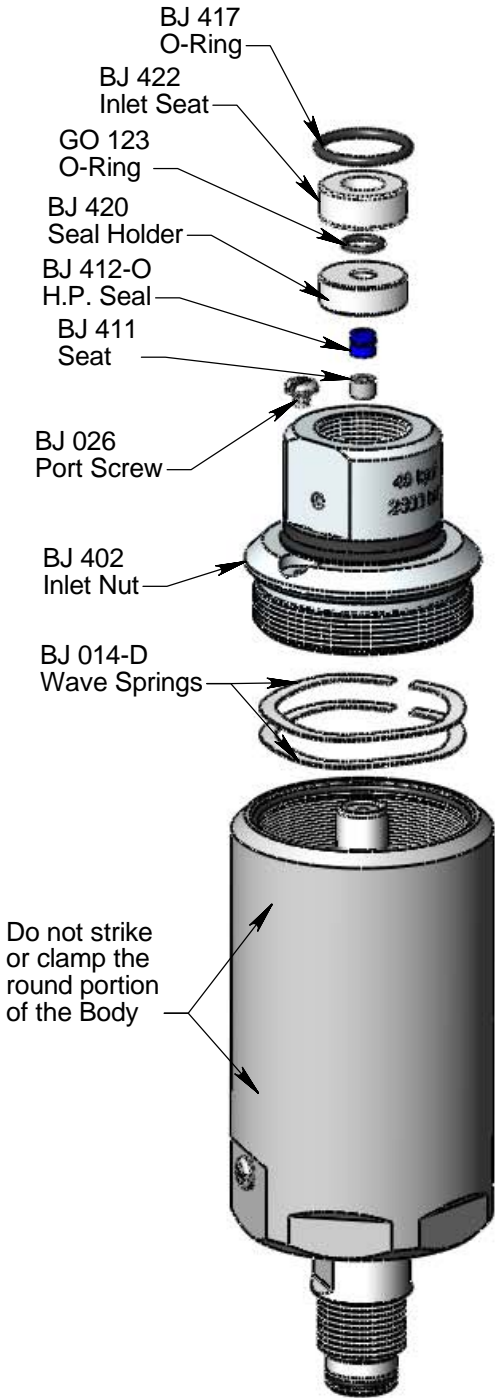

1. Remove the Port Screw (BJ 026) from the Inlet Nut (BJ 402). Unscrew the Inlet Nut from the Body.
2. Remove the O-Ring (BJ 417) from the Inlet Nut; push out the Seal Holder (BJ 420) and Inlet Seat (BJ 422) with the Seat (BJ 411) and H.P. Seal (BJ 412-O).
3. Remove the Wave Springs (BJ 014-D).
4. Remove the Shaft Seal (RJ 029) from the Inlet Nut only if it is damaged.
5. Remove the O-Ring (BJ 008) and Weep Seal (BJ 021-S) from the Inlet Nut.

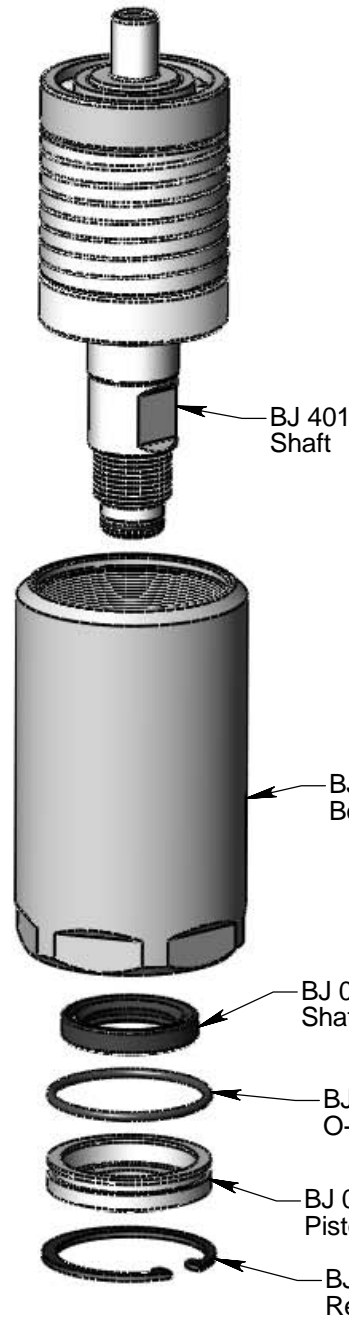
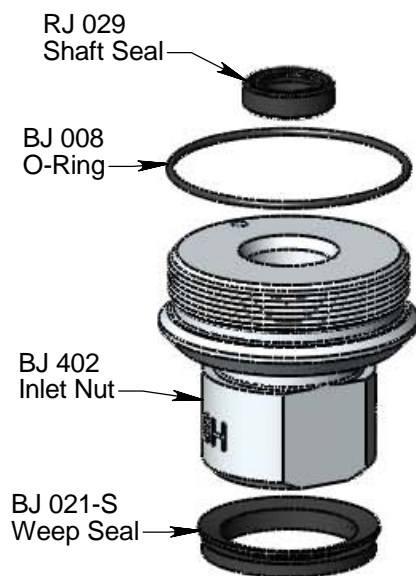

6. Push the Shaft (BJ 401) with Bearings out of the Body.
7. Remove the Retaining Ring (BJ 032) from the Body, followed by the Piston (BJ 028).
8. Remove the Shaft Seal (BJ 010-D) from the Piston only if it is damaged.
9. Carefully remove Bearings (SG 009 and BJ 007) from Shaft. Do not ding the Shaft.
10. Remove the O-Ring (BJ 072) and Backup Ring (BJ 071) from Shaft.

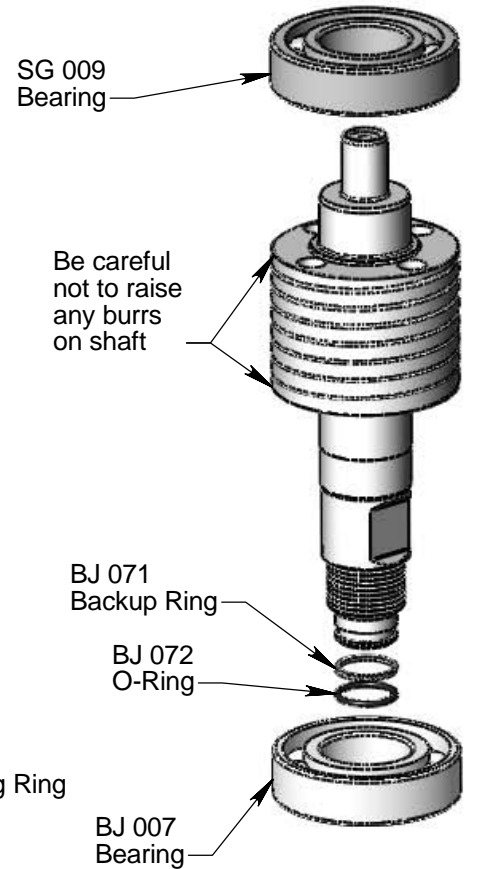

Assembly:

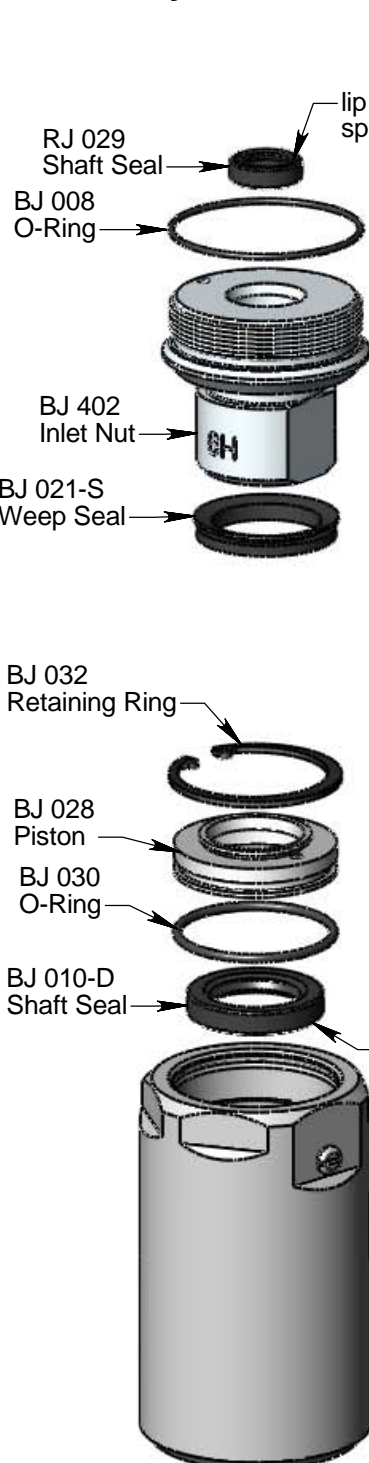

1. Install Shaft Seal (RJ 029) in Inlet Nut (BJ 402) as shown.
2. Place O-Ring (BJ 008) over threads of Inlet Nut.
3. Install Weep Seal (BJ 021-S).
4. Install Shaft Seal (BJ 010-D) in Piston (BJ 028) as shown.
5. Place O-Ring (BJ 030) in groove around Piston.
6. Push Piston into Body, install Retaining Ring (BJ 032).

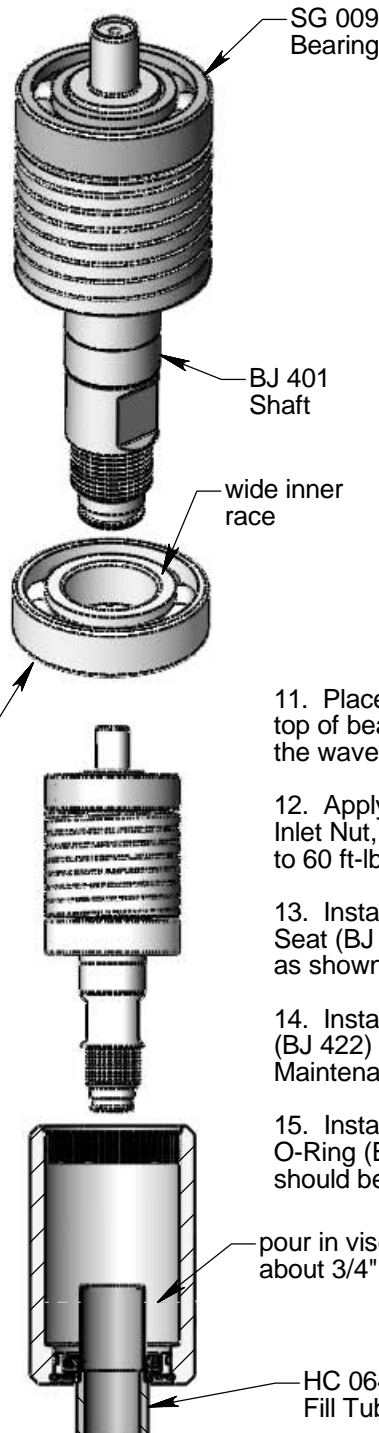

7. Press Bearing (SG 009) onto seal end of Shaft (BJ 401); press Angular Contact Bearing (BJ 007) onto threaded end of shaft oriented as shown.
8. Insert Fill Tube (HC 064) thru shaft seal in Piston, up to shoulder on Fill Tube.
9. Pour viscous fluid into Body, about 3/4" deep.
10. Slide Shaft into Body, allowing Shaft to push out the fill tube. Fluid should come up around shaft.
11. Place Wave Springs (BJ 014-D) on top of bearing. Add viscous fluid until the wave springs are covered.
12. Apply anti-seize to the threads of Inlet Nut, thread into Body and tighten to 60 ft-lb. Install the Port Screw (BJ 026).
13. Install the H.P. Seal (BJ 412-O) and Seat (BJ 411) in Seal Holder (BJ 420) as shown in the Maintenance Section.
14. Install Seal Holder and Inlet Seat (BJ 422) in Inlet Nut as shown in the Maintenance Section.
15. Install Backup Ring (BJ 071) and O-Ring (BJ 072) on Shaft; the O-Ring should be nearest the end of Shaft.

