

## Description:

The BJV-20K has a 3/4 medium pressure female inlet connection. It is capable of working pressures up to 22,000 psi (1500 bar) and flow rates of 10 to 60 gpm. Speed is controlled by a viscous fluid; a thick fluid (BJ 048-S) is used for speeds of 10 to 80 rpm, and a thinner fluid (BJ 048-F) is used for speeds of 50 to 200 rpm. The fluid in the swivel can be changed to provide either fast or slow rotation. The heads have either 1/4 npt ports or a special port to receive an extension nipple with an O-ring seal, shown at right.

Stamped or engraved on the BJ nozzle head is an R followed by a number, such as R12 or R.35. This number is the offset of the head that makes it rotate. This number must match the flow range given in the table below. If your flow is 20 gpm, you should have a head with R35 on it. If it has an R20 or R12 on it, the tool will not rotate, because not enough rotating force (torque) will be produced. If the head is an R60, the tool will spin too fast and wear out quicker.

The next step is to determine where the jets should go in the head. Remember that using more jets will mean they must be smaller and not hit as hard. The thrust of the jets can be used to pull the tool thru the pipe. If no pull is needed, as few as two jets can be used, just in the 90 degree ports. If jet pull is needed, use two jets in the back ports, as big as they need to be to produce the pull needed, then put jets in other ports for effective cleaning. There is also a pulling ring (HC 097) available that attaches to the head, so a cable can be used to pull the tool so no back jets are used. When installing nozzles into the head, we recommend using Parker Thread Mate and Teflon Tape.

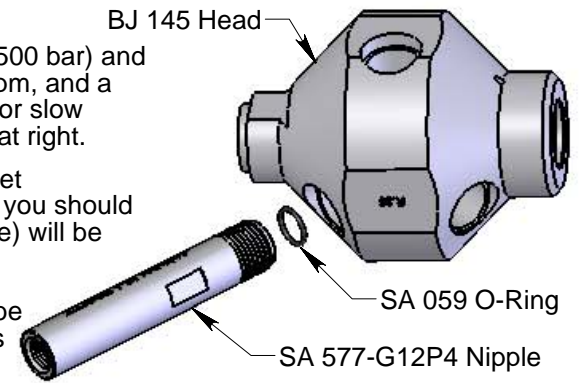

Offset	R60	R35	R20	R12
Flow	10 - 15 gpm	15 - 24 gpm	24 - 40 gpm	40 - 60 gpm

## Operation:

Make sure there is an operator controlled dump in the system, operated by the person closest to the cleaning job. Flush out the high pressure hoses before connecting BJV to hose end. It is recommended that the hose be marked a few feet from the end with a piece of tape so the operator knows when to stop on the way back out. Once the BJV is attached to the hose end, position it in the pipe or vessel to be cleaned. The high pressure seal may leak initially; it should stop when pressure is increased and rotation begins. Close the dump and slowly bring up to pressure the first time, to make sure no nozzles are plugged and that the jet thrust is correct. The swivel should begin to slowly rotate. Once operating pressure is reached, feed the tool into the pipe to begin the cleaning job. Allow the jets time to do their work by feeding the hose out at a controlled rate. Once the work is complete and the tool is disconnected from the hose, blow out all water to prolong the life of the tool. A small amount of oil can be blown into the inlet nut as well.

## Troubleshooting:

**Head will not rotate:** First try rotating head by hand and see if it feels rough or gritty to turn. If it does, the tool must be disassembled and repaired. If the head starts to rotate but as pressure is increased it slows down and stops, it likely has bad bearings. If the tool feels okay, check to see if any nozzles are plugged; even if a nozzle is only partially blocked it can keep the head from rotating. Nozzles must be removed from the head to properly clean them; it does not do any good to poke the material plugging the nozzle back into the head, as it will just replug a nozzle. If none of these are the problem, the jets are too small or the head offset is not correct; refer to the above description about the head offset and double check the nozzle sizes to make sure they are correct for the expected flow rate.

**Head spins too fast:** Check the nozzles sizes and head offset to make sure they are correct; refer to the description section above. If these are correct, it is likely that the swivel is low on viscous fluid, or the viscous fluid has water in it. The best thing to do is drain all the fluid, wipe the parts clean and refill with the proper fluid. Check that the shaft seals are still good and will keep the fluid from leaking out.

**Seal Leak:** The seal may initially leak at low pressures, but should pop closed as pressure is increased. If operating pressure is reached and the seal is leaking continuously, the high pressure seal may need to be replaced. Refer to the maintenance below.

**Seals wear out quickly:** The tool must be disassembled and inspected. The carbide seat should be checked for being installed in the right direction, and it should not have any chips or erosion marks on it. Check the bore of the seal holder (BJK 120) for groove; replace if it has a groove.

## Maintenance: \*Blow out all water with compressed air before storing tool!

**Keeping the tool full of viscous fluid is the most important maintenance procedure for long tool life. It should be done when the tool begins to rotate faster than usual; this can occur between 50 and 100 hours.**

1. Hold swivel upright as shown. Remove the Port Screws (BJ 026) from the Inlet Nut and the Body.
2. Fill the Syringe (BC 410) by unscrewing the handle and pouring the correct viscosity viscous fluid in from the back end.
3. Thread Syringe into port in Body; squeeze fluid into swivel. Repeat until clean fluid comes out port in Inlet Nut. Remove Syringe and install Port Screws.

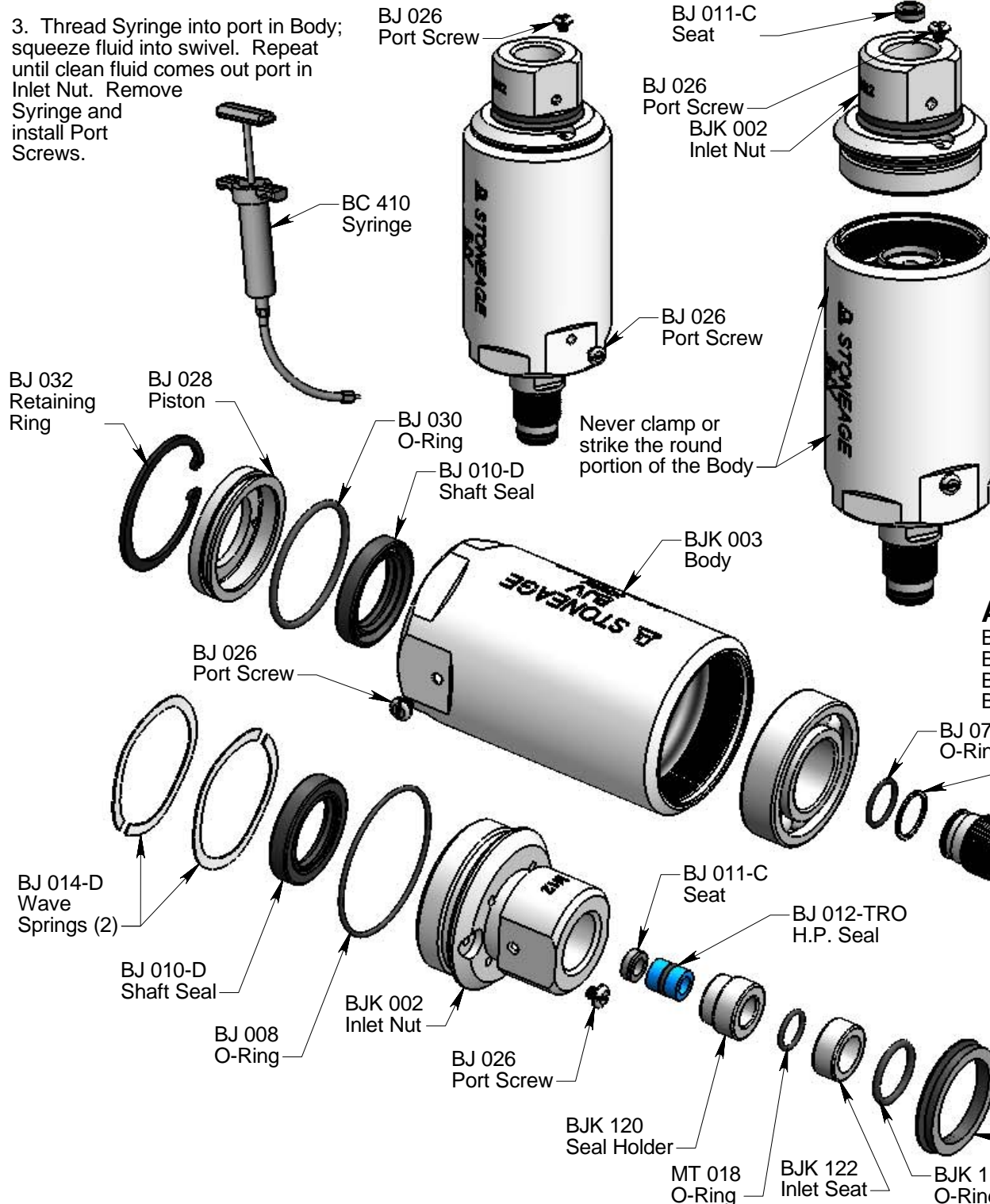

## Detailed View:

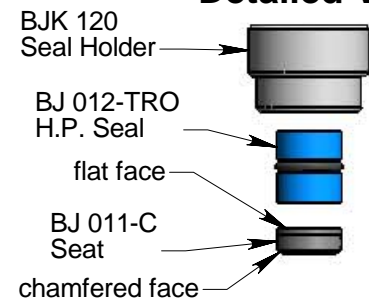

### To replace the High Pressure Seal:

1. Remove the Port Screw (BJ 026) in the Inlet Nut. Unscrew the Inlet Nut (BJK 002) from the Body.
2. Remove the O-Ring (BJK 117) from the rear of the Inlet Nut.
3. Push out the Seal Holder (BJK 120), with Seat (BJ 011-C), H.P. Seal (BJ 012-TRO) and the Inlet Seat (BJK 122).
4. Inspect the Seat (BJ 011-C) for chips or erosion pits. Inspect the face of the Shaft where the Seat makes contact for dings, dents, or erosion.
5. Apply anti-seize to the threads of the Inlet Nut (BJK 002) and thread into Body. Tighten to 50 ft-lb and install the Port Screw (BJ 026).
6. Apply grease to new H.P. Seal and install in Seal Holder (BJK 120). Apply grease to the flat face of the Seat (BJ 011-C) and stick this side to the H.P. Seal, as shown in detail below.
7. Place this assembly onto the Inlet Seat (BJK 122) and slide all of these parts into the Inlet Nut. They should go in far enough to allow placing of the O-Ring (BJK 117) in the groove behind them.

### Available Maintenance Kits:

- BJK 600 Service Kit (Includes items needed for maintenance)
- BJK 602 Seal Kit (Includes parts needed for one seal change)
- BJK 610 Overhaul Kit (Includes parts needed for tool rebuild)
- BJK 612 Tool Kit (Includes tools to aid assembly)

## Disassembly:

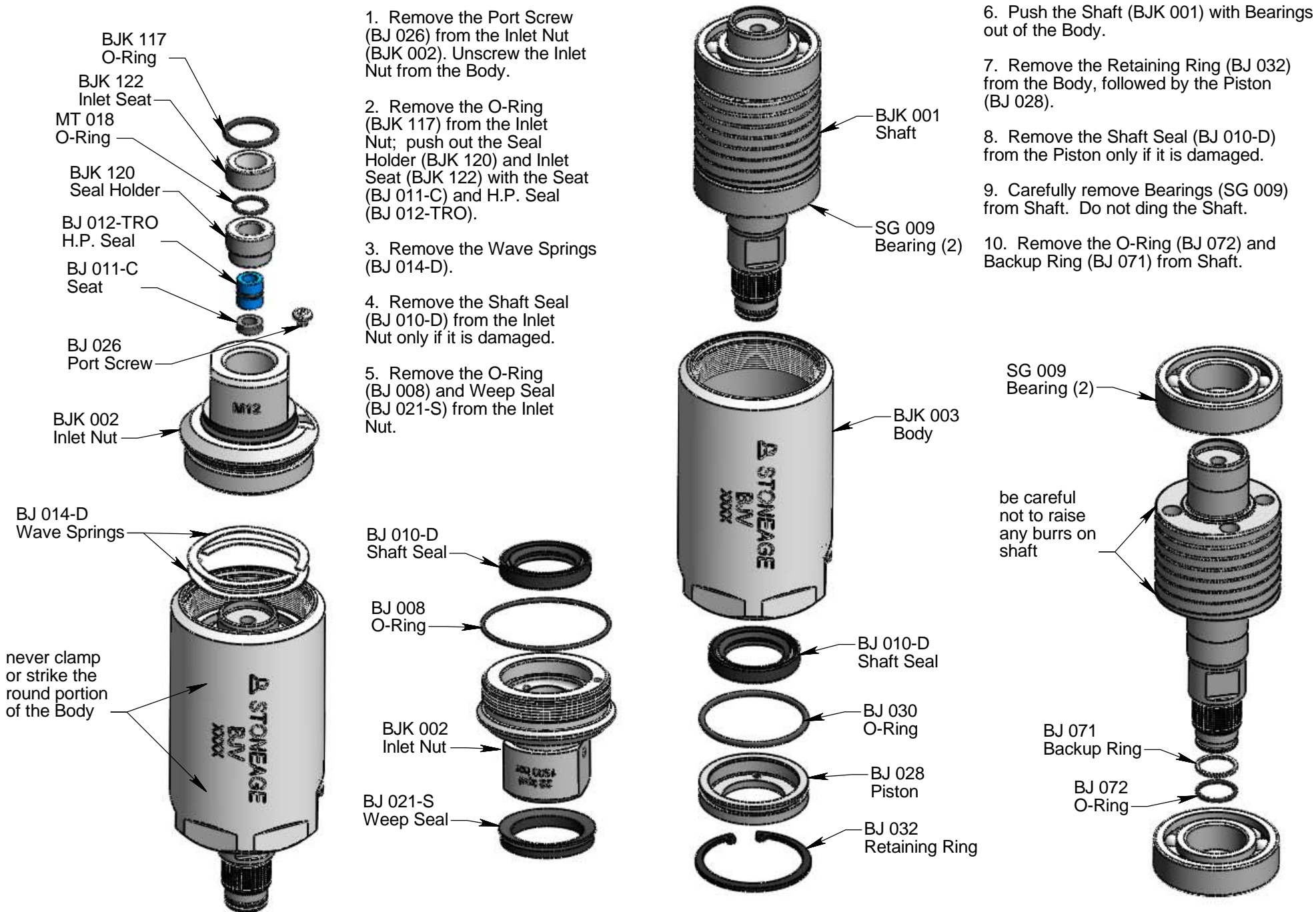

## Assembly:

