

Badger™ Self-Rotary Swivel (BA-P6, BA-20K)

Description:

The Badger™ Rotary Waterblast Nozzle was designed for waterblast cleaning of pipes as small as 4 inch with elbows. The BA-P6 has a 3/8 npt female inlet connection and a maximum operating pressure of 15,000 psi (1035 bar). The BA-20K has a 3/4 type M male inlet connection and a maximum operating pressure of 22,000 psi (1500 bar). Two rotation speed ranges are available for each tool; a thick fluid is used for rotation speeds of 20 to 100 rpm, and a thinner fluid is used for rotation speeds of 75 to 250 rpm. The fluid in the swivel can be changed to provide either fast or slow rotation. The Badger™ heads have 1/8 npt ports; one at 15 degrees, two at 100 degrees, and two at 135 degrees.

Engraved on each head is R16 or R22; this number is the offset of the head that makes it rotate. The flow range for each head is given in the table; nozzle sizes must be selected to fit within this flow range. If the flow is less than the range shown, the tool will not rotate; if it is more than the allowable the tool will rotate too fast and wear out the seals and bearings.

Press. psi	Flow Range	
	R22	R16
10,000	13-21	20-30
15,000	13-17	18-30
22,000 (1500 bar)	12-18	15-25

Operation:

The first step is to determine the jet sizes. Jet thrust is used to pull the tool through the pipe. An estimate of the amount of pulling force required is useful and depends on the number of elbows and any vertical climbs that must be made. On a horizontal run with no elbows, 1 pound of pull is required for every ten feet. When climbing vertically, the pulling force must equal the weight of the tool and the hose. Typically, larger jet sizes using 50 to 80 percent of the total flow are used in the back ports. As little as 10 percent of the total flow is given to the front jet, because it pushes the wrong direction and is only used to open up blockages. The remaining flow goes to the 100 degree ports, which do help pull as well. Nozzles selected should be matched pairs, except the front jet. When installing nozzles, we recommend using Parker Thread Mate and Teflon tape. Because of the short length of the Badger, the tool turn can around in large pipes and come back at the operator at a high rate of speed. If cleaning larger pipes, a rigid pipe "stinger" should be used between the hose and the tool. It is recommended that the rigid length of the tool including hose end is one and a half times the inside diameter of the pipe being cleaned. Make sure there is an operator controlled dump in the system, operated by the person closest to the cleaning job. Flush out the high pressure hoses before connecting the Badger. It is recommended that the hose be marked a few feet from the end with a piece of tape so the operator knows when to stop on the way back out. Position the tool in the pipe opening. Close the dump and slowly bring up to pressure the first time to make sure no nozzles are plugged and the jet thrust is correct. The Badger should begin to slowly rotate. Once operating pressure is reached, feed the tool into the pipe to begin the cleaning job. Allow the jets time to do their work by feeding the hose out at a controlled rate. When the work is complete and the tool is disconnected from the hose, blow out all water to prolong the life of the tool. A small amount of oil can be blown into the tool as well.

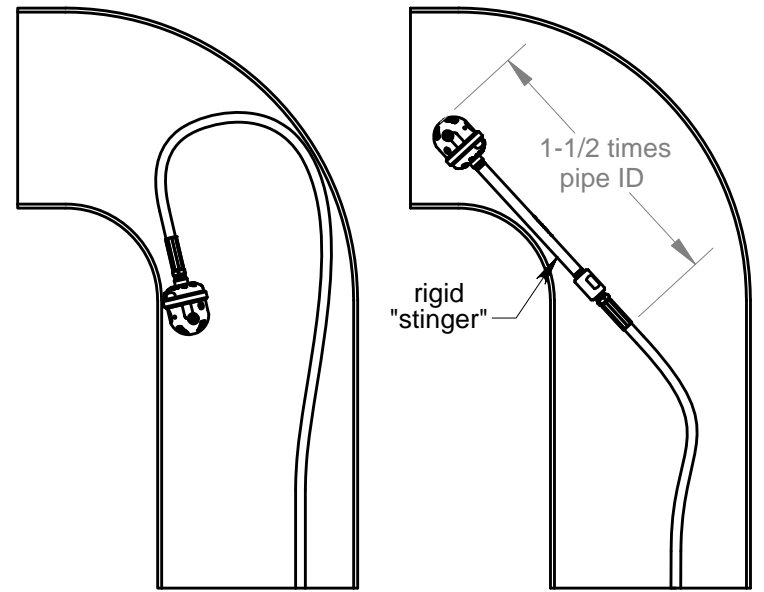

IMPROPER USE:
Badger will turn around in large diameter pipe
VERY DANGEROUS!

PROPER USE:
Badger with rigid "stinger" to prevent turnaround, still able to pass thru elbows

Troubleshooting:

High-pressure seal leak: The high pressure seal may leak initially at lower pressures, but should pop closed as pressure is increased. A continuous leak at operating pressure from the weep holes indicates the need to replace the HP Seal and Seat. HP Seals wearing out too quickly can be an indication that the shaft bore is worn, the HP Seal is installed upside-down, or the tool is over spinning. Over spinning is caused by low or contaminated viscous fluid, water in the fluid chamber (replace shaft seals), or too much jet torque. Refilling the viscous fluid every 30-40 hours of operation is important for proper speed control. Only use StoneAge recommended viscous fluid.

Tool will not rotate: Check the nozzles for plugging or wear (nozzles have to be removed to check for obstructions), Check that the nozzle sizes are correct for the desired flow and that the desired flow matches the head flow range. Check that the nozzle sizes are installed in a balanced configuration. If the tool feels rough when manually rotating the head, this indicates internal damage. Replace bearings, shaft seals, viscous fluid, and check the Inner and Outer Discs for flatness. These discs can be deformed if tool is reassembled when discs are not properly aligned with BA 018 Pins.

Maintenance:

The most important item in maintaining the Badger™ is keeping the tool full of viscous fluid, which controls the rotation speed. As the viscous fluid is lost or contaminated, the rotation speed of the tool will increase, which shortens the high pressure seal and bearing life.

To fill the Badger™ with viscous fluid:

1. Remove the Port Screws (BJ 026) in the Nut and Head.
2. Fill the Syringe (BC 410) with viscous fluid by removing the end near the handle, pulling out the plunger, and pouring the viscous fluid in from the back end.
3. Thread the syringe end into the port in the Head, and squeeze fresh viscous fluid in until clean viscous fluid comes out the port in the Nut. Hold the tool so the port in the Nut is the highest point.
4. Remove the Syringe and install the Port Screws.

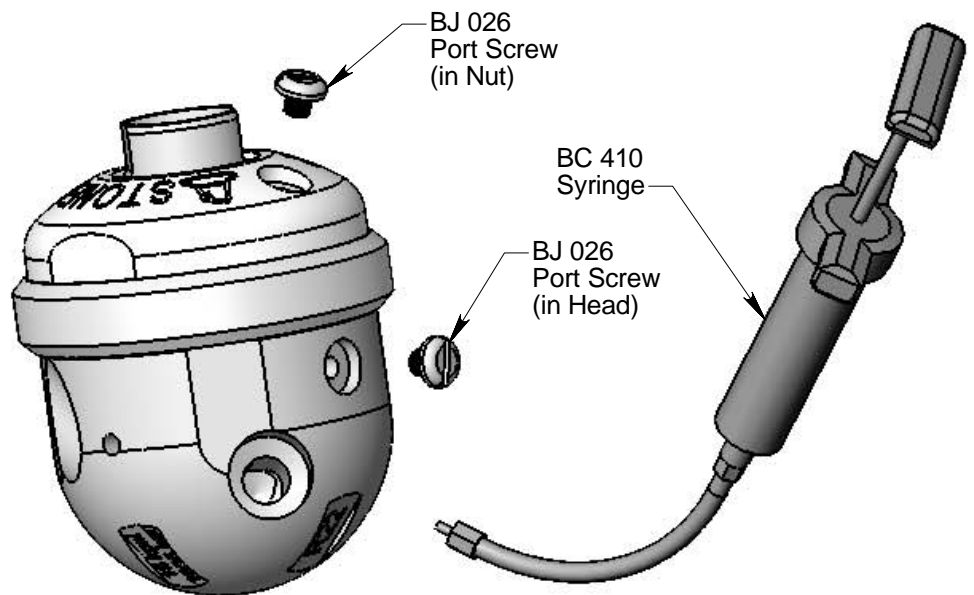
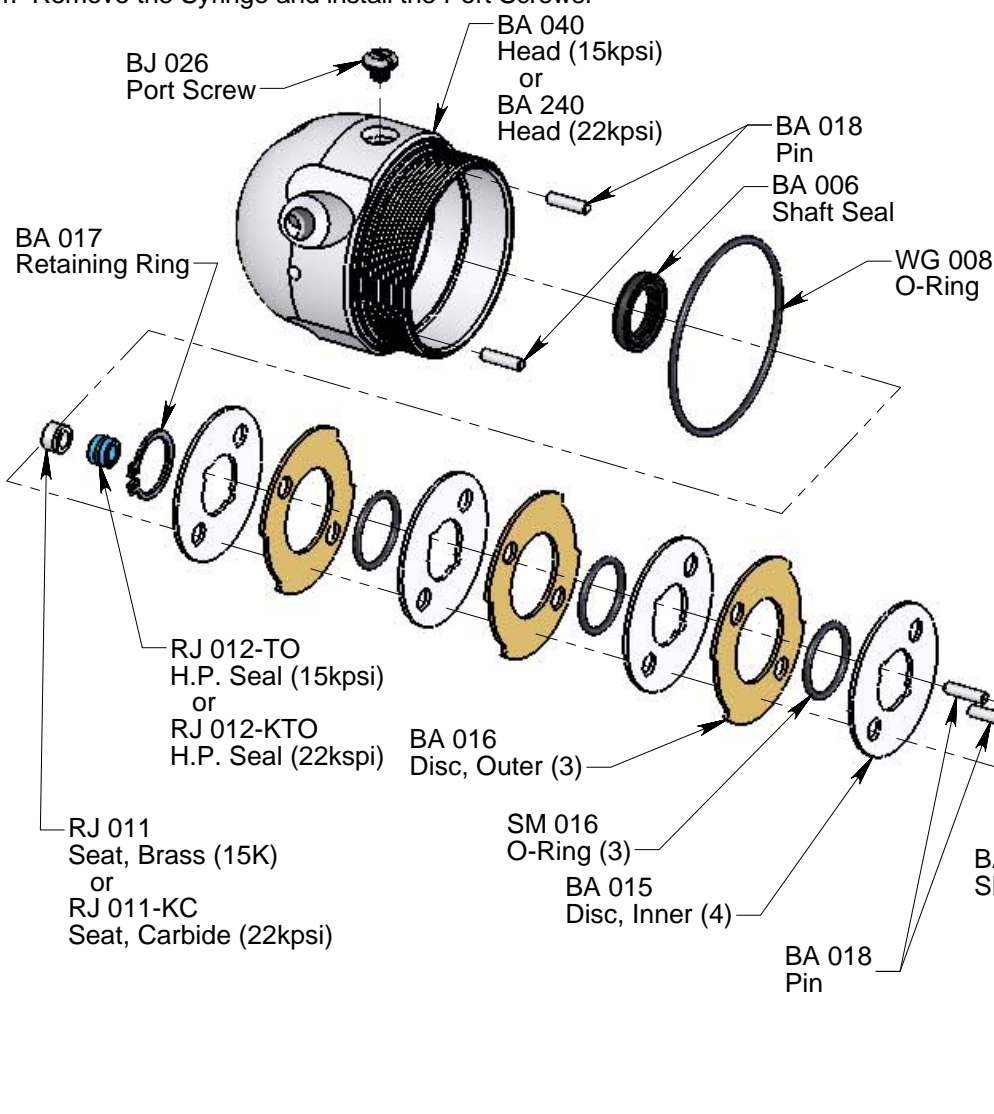

Available Maintenance Kits:

- BA 600-x Service Kit (Includes items needed for maintenance)
- BA 600-20k-x Service Kit (Includes items needed for maintenance)
- BA 602 Seal Kit (Includes parts needed for one seal change)
- BA 610-x Overhaul Kit (Includes parts needed for tool rebuild)
- BA 610-20k-x Overhaul Kit (Includes parts needed for tool rebuild)
- BA 612 Tool Kit (Includes tools to aid assembly)

Badger™ Self-Rotary Swivel (BA-P6, BA-20K)

Disassembly:

1. Unscrew the Nut (BA 002) from the Head (BA 040/240).

2. Pull the Shaft (BA 001/201) out of the Head.

4. Remove the Retaining Ring (BA 017) from the Shaft.

5. Pull the Discs (BA 015, BA 016) and O-Rings (SM 016) off of the Shaft.

6. Press the Bearing (UH 009) off of the Shaft.

7. There is no need to remove the Pins (BA 018) from the Shaft; however, if they fall out do not lose them.

10. Remove the Port Screw (BJ 026) from the Head.

11. Remove the Shaft Seal (BA 006) and O-Ring (WG 008) if they are damaged.

12. There is no need to remove the Pins (BA 018); however, if they fall out, do not lose them.

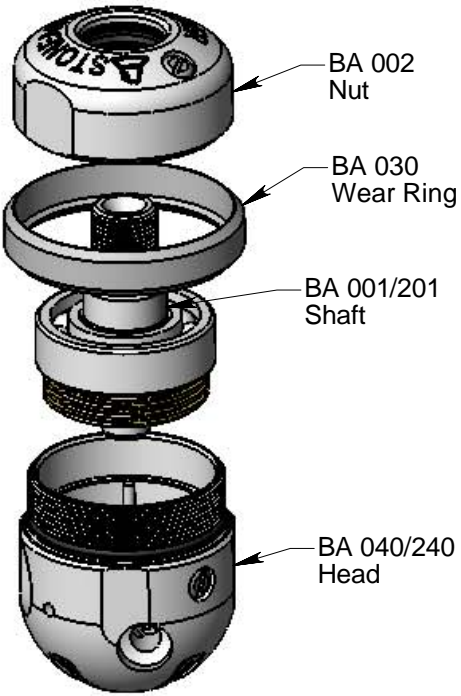

3. Remove the Seat (RJ 011/RJ 011-KC) and H.P. Seal (RJ 012-TO/RJ 012-KTO) from the bore of the Shaft.

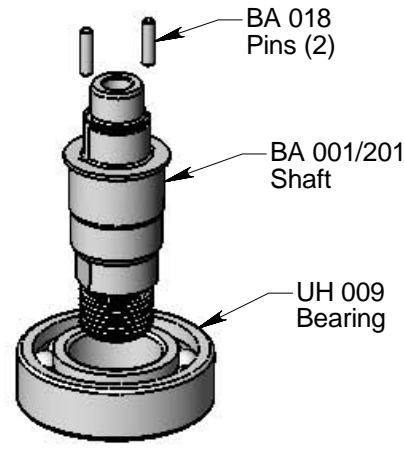
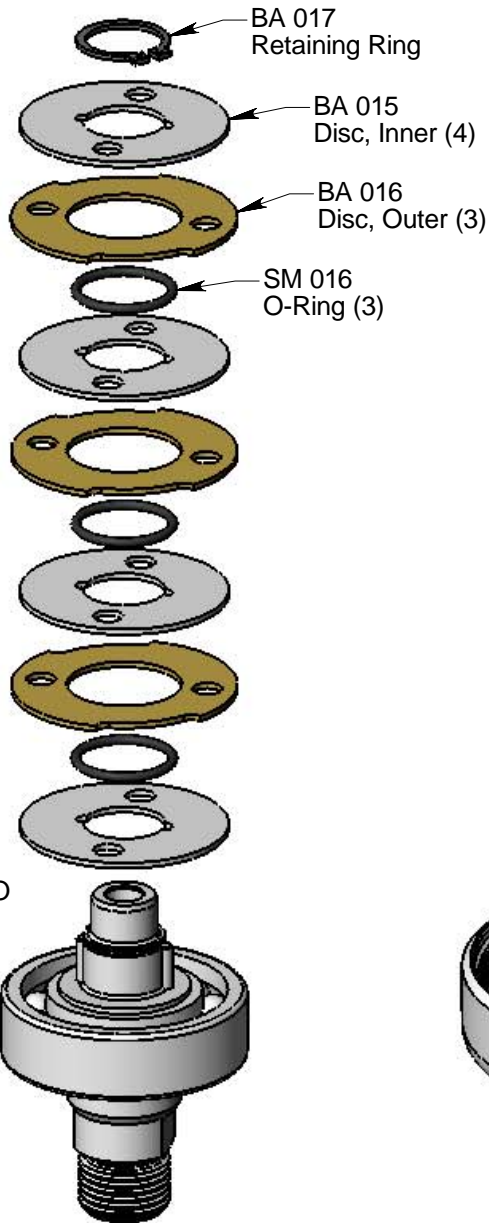
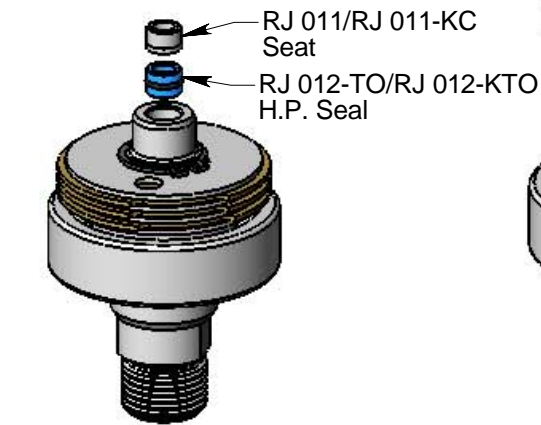

8. Remove the Shaft Seal (BA 007) if it is damaged.

9. Remove the Port Screw (BJ 026) from the Nut.

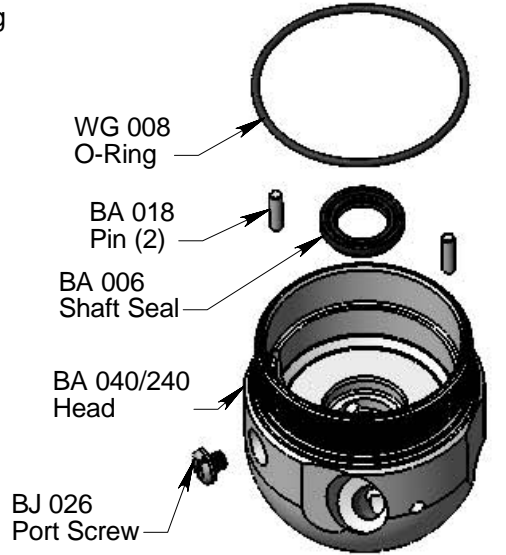
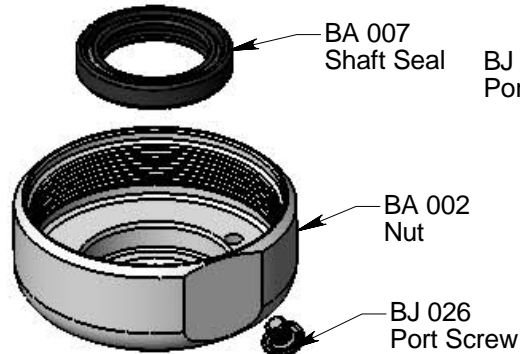

Assembly:

1. Press Bearing (UH 009) onto Shaft (BA 001/201).

2. Check that Pins (BA 018) are installed in Shaft.

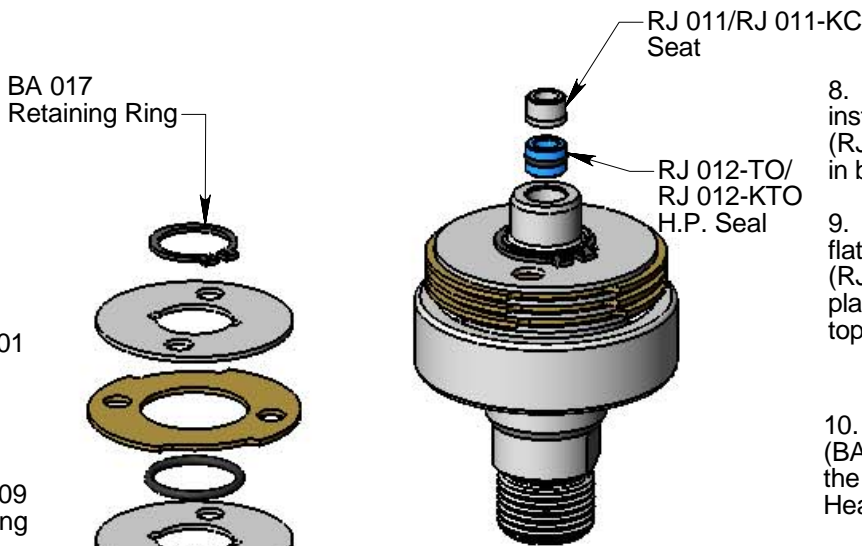

3. Place an Inner Disc (BA 015) on Shaft, aligning with pins.

4. Place an O-Ring (SM 016) on top of this Disc, stretched around the pins.

5. Place an Outer Disc (BA 016) on top of this.

6. Repeat these steps, until there are three Outer Discs and four Inner Discs on Shaft.

7. Push down on top disc and install the Retaining Ring (BA 017) in the groove around Shaft.

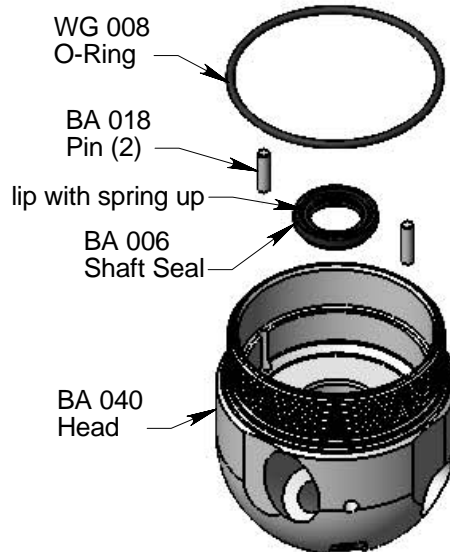
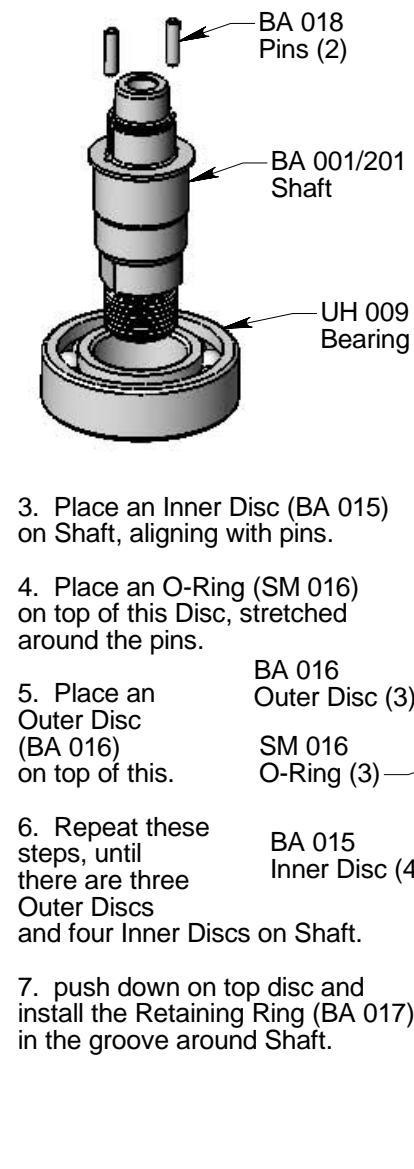

8. Apply grease to and install the H.P. Seal (RJ 012-TO/RJ 012-KTO) in bore of Shaft.

9. Apply grease to the flat face of the Seat (RJ 011/RJ 011-KC) and place in bore of Shaft, on top of Seal, as shown.

10. Install Shaft Seals (BA 007 and BA 006) in the Nut (BA 002) and Head (BA 040/240) as shown.

11. Place O-Ring (WG 008) over threads and into groove of Head.

12. Check that the Pins (BA 018) are installed in the Head.

13. Align the notches on the Outer Discs with the pins in the Head; slide shaft assembly into the Head.

14. Apply anti-seize to threads on Head; install Wear Ring (BA 030) onto the Nut (BA 002); thread the Nut onto the Head. Tighten to 50 ft-lb.

15. Use syringe to fill the tool with viscous fluid as shown in the Maintenance Section; install the Port Screws (BJ 026).

